

The diagrams below illustrate how to connect the AC Tech QC, MC, SCF and TCF Series drives and the EPM Programmer to a computer in order to use the TechLink software.

**NOTE: 1** When using serial communications, terminal 2 on the drive MUST be connected to chassis ground.

## EPM Programmer

The EPM Programmer is RS-232, so it can be connected directly to the computer, using a standard 9-pin serial cable with a male connector (DB9M) for the EPM Programmer connection and a female (DB9F) for the computer connection. These are straight through connections of pins 2, 3, and 5. Do not use a “null modem” cable as this internally crosses pins 2 and 3.

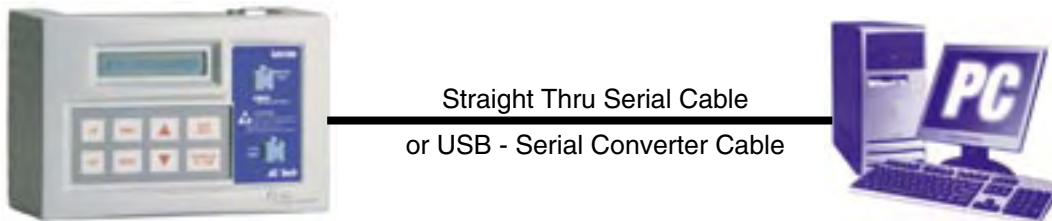

## SCF & TCF Series

The SCF & TCF Series is RS-485, so a RS-232 to RS-485 or USB to RS-485 converter is required. The converter connects to the computer using a standard serial connection. A twisted pair connects the converter to the drive.

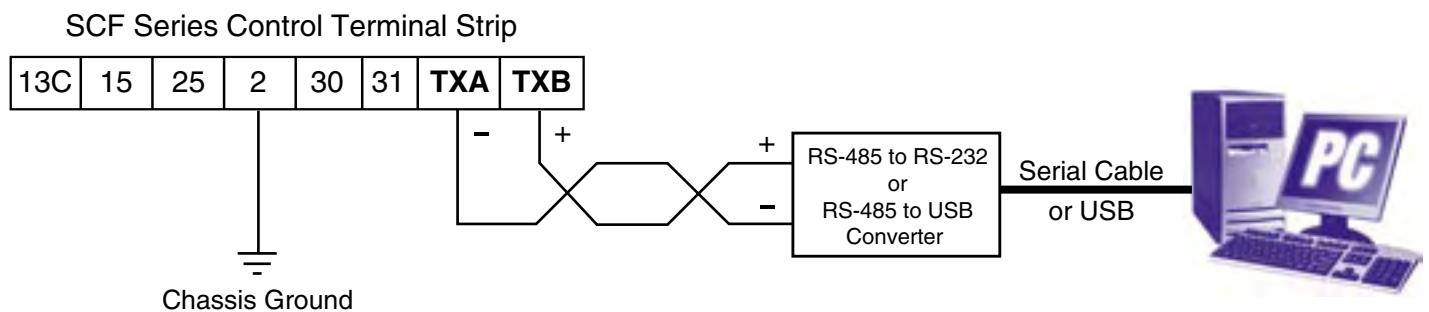

**NOTE: 2** Refer to the converter manufacturer’s instructions for proper converter configuration. The converter is not supplied by AC Tech.

## MC Series

The MC Series is RS-485, so a RS-232 to RS-485 or USB to RS-485 converter is required. The converter connects to the computer using a standard serial or USB connection. A twisted pair connects the converter to the drive.

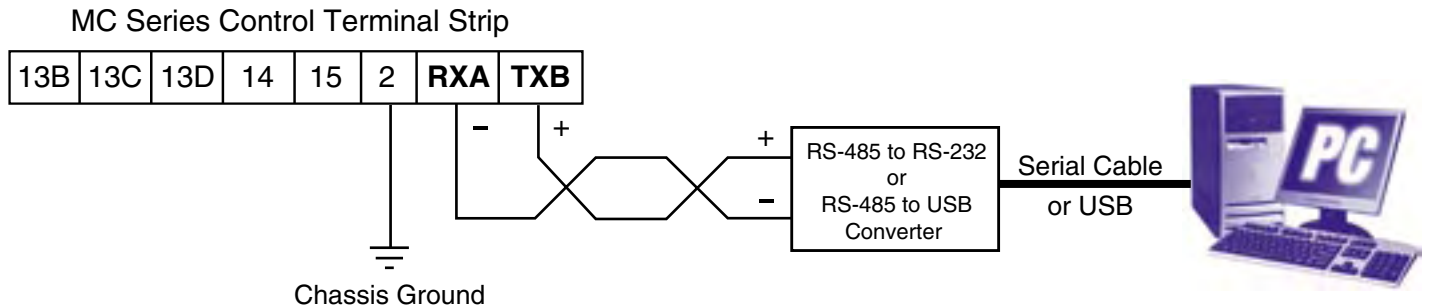

**NOTE: 3** Refer to the converter manufacturer's instructions for proper converter configuration. The converter is not supplied by AC Tech.

## QC Series

The QC Series is RS-232, therefore it can be connected directly to the computer. The pin-out for a 9-pin serial cable is shown below:

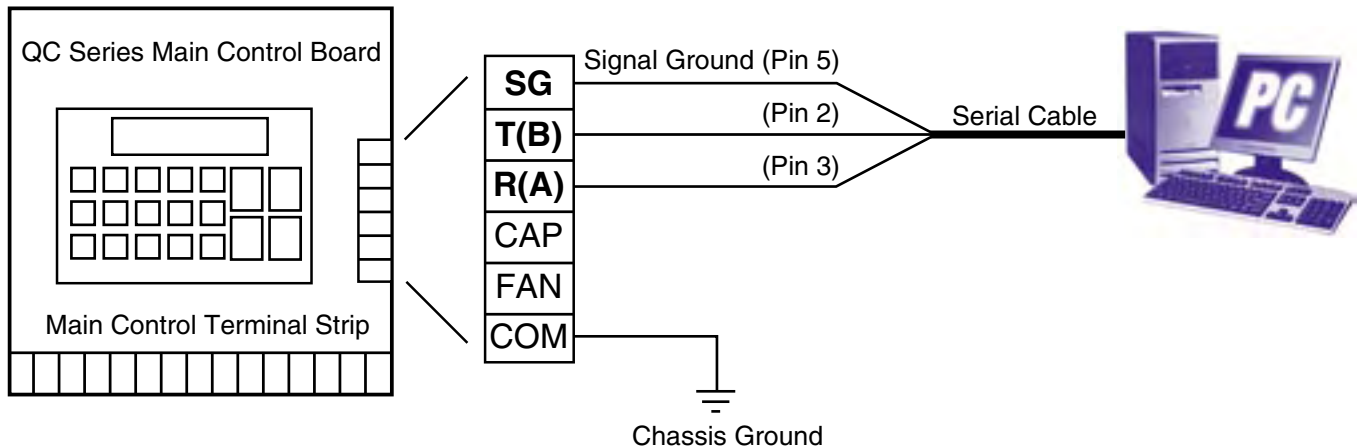

**NOTE: 4** The COM terminal is electrically equivalent to terminal 2 on the Main Control Terminal Strip.