

**Introduction**

Sanitary electromagnetic flowmeters LF490 series are designed for applications handling food and beverages. Sanitary flowmeters must be structured in such a way that operation and handling is simple, easy and thorough for the purpose of sanitary control such as cleaning (CIP/SIP), sterilization and drying. The sanitary flowmeter has features provided with normal electromagnetic flowmeters and by using sanitary fittings for pipeline connections fluid does not remain in any place along the detector pipeline. Therefore, it is fit for flowrate measurement for food and beverages. The electromagnetic flowmeter uses Faraday's Law of electromagnetic induction to measure the process flow. The device consists of two units: a detector, through which the fluid to be measured flows and in which low-level signals proportional to flow rates are obtained; and a converter, which supplies excitation current to the detector, and amplifies the signals from the detector and then processes and converts the signals into the 4-20mA dc current signal or communication signal. With the unique patented **Mount-Anywhere** magnetic field distribution technology, the meter is highly immune to upstream flow disturbances. Combined with a multi-functional converter LF610 (combined type) or LF612 (separate type) equipped with its patented **Noise-Sentry** original noise-suppression circuit and advanced algorithms. The LF490 has a very high tolerance to noise, giving the unit a very stable output even for slurry fluid measurement. IR (Infrared) switches enable parameter setting of the converter without removing the cover. Flow direction can be set in either way, and its unique 128 x 128 dot matrix LCD display allows the LCD to be rotated electronically to 90, 180 and 270 degrees without opening the cover.



**LF490/LF610**      **LF490**      **LF612**  
**LF494/LF610F**      **LF494**      **LF612F**

**Figure2. LF490 series flowmeters**



Certification number  
 Z01207

The AF900 hand-held terminal (HART\*<sup>1</sup> communicator) can be used to communicate with the flowmeter from a remote place. PROFIBUS-PA\*<sup>2</sup> interface is available as an option.

\*1: HART protocol (Highway Addressable Remote Transducer) is a communication protocol for industrial sensors recommended by the HCF (HART Communication Foundation).

\*2: PROFIBUS is the communication protocol for factory and process automation that the PROFIBUS Organization recommends. Instead of analog control with a conventional analog signal (4-20mA), it is the fieldbus which digitizes all signals. Flowmeters support PROFIBUS-PA.

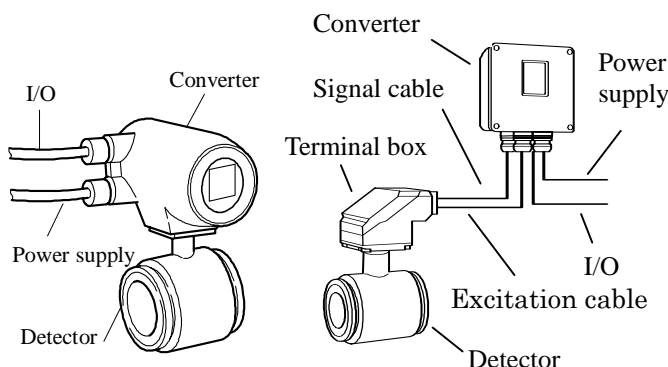

**Combined type**  
**LF490/LF610**  
**LF494/LF610F**

**Separate type**  
**LF490/LF612**  
**LF494/LF612F**

**Figure1. Configuration**

## Specifications

### ■ Overall Specifications

#### Measurement range in terms of flow velocity:

0–1.0 ft/s to 0–32.8 ft/s (0–0.3 m/s to 0–10 m/s)  
 0–0.3 ft/s to 0–1.0 ft/s (0–0.1 m/s to 0–0.3 m/s)  
 range is available optionally.

#### Accuracy: $\pm 0.2$ % of Rate\*

- \* This pulse output error result is established under standard operating conditions at Toshiba's flow calibration facility, Fuchu Japan. (NIST Traceable).
- \* Individual meter measurement error may vary up to  $\pm 0.5\%$  of Rate at 1.64 ft/s (0.5m/s) or more and  $\pm 0.3\%$  of rate  $\pm 0.039$  inch/s (1mm/s) at 1.64ft/s (0.5 m/s) or less.
- \* Current output: plus  $\pm 8\mu\text{A}$  (0.05% of span.)
- \* Refer to individual calibration data for each individual meter's measurement error.

**Fluid conductivity:**  $5\mu\text{S/cm}$  minimum

#### Fluid temperature:

14 to 248 °F (–10 to +120 °C)

**Ambient temperature:** –4 to 140 °F (–20 to +60 °C)

**Structure:** IP 67 and NEMA 4X Watertight

#### Power consumption:

17 W(27VA) or less  
 19 W(29VA) or less (with PROFIBUS)

#### Conformance to European Community Directives:

EMC directive 89/336/EEC  
 The low voltage 93/68/EEC

#### 3A standard (LF490 and LF494 detectors):

Approved for 3A standard with FDA approved Teflon PFA lining.

#### Approved hazardous location certifications:

Model: LF494/LF610F and LF494/LF612F  
 cFMus explosion proof:  
 FM Class I, Division 2, Groups A,B,C, and D.  
 FM Class II, Division 2, Groups E, F and G.  
 FM Class III.

#### Detector and converter combination:

LF490/LF610 : Combined type for standard specification.  
 LF490/LF612 : Separate type for standard specification.  
 LF494/LF610F: Combined type with Ex approval of Class I, Division 2 (cFMus).  
 LF494/LF612F: Separate type with Ex approval of Class I, Division 2 (cFMus).

#### Mount-Anywhere Technology:

Thanks to TOSHIBA's unique patented magnetic field distribution technology, the meter is highly immune to upstream flow disturbances.

A minimum of 1D (diameter) length of upstream straight pipe from the flange is required to maintain the performance specification.

**Note :** The test results were obtained and demonstrated at TOSHIBA's flow calibration facility, Fuchu Japan.

### ■ Model LF490 and LF494 Detectors

#### Fluid pressure:

–15 to 300 psi, or –1.0 to 20 bar (–0.1 to 2.0 MPa)

**Note:** This pressure is the allowable pressure for the detector. The actual pressure will be restricted by the type of connection method. For example, in the case of sanitary clamp type, the maximum pressure is 150 psi or 10 bar(1.0 MPa).

**Note:** The test pressure before shipping from the factory is equal to twice the nominal pressure rating of the customer specified flange connection during 15 minutes.

#### Connection method:

Sanitary clamp type (ISO 2852)

#### Note:

Tri-clamp® can connect except meter size 4" (100 mm).  
 Tri-clamp® is a registered trademark for Tri-Clover Inc.

#### Principal materials:

**Case** — stainless steel

**Linings** — Teflon PFA (FDA approved)

**Note:** Teflon liners are mechanically retained for full vacuum service.

**Electrodes** — 316L stainless steel (std.)

**Note:** Electrodes are electro-chemically polished after mechanically buffed.

**Sanitary fittings** — 304 stainless steel (std.)

**Seal gaskets** — Silicon rubber (FDA approved)

**Note:** See Table 5 for optional materials and other related information.

**Measuring tube material** — 304 stainless steel

**Coating:** no coating (std.)

**Dimensions and weights:** See Figures 3 to 6.

**Cable connection port:** for separate type detectors.

**Cable glands** —

LF490: Provided as standard, R(PT) 1/2 male screws.

LF494: Not provided, 3/4–14NPT male screws are required.

**Applicable diameter** —

0.433 to 0.512 inch (11 to 13mm)

## ■ Model LF610 and LF612 converters

### Input signals

**Analog signal** — the voltage signal from detector, proportional to process flow rate (for LF612 separate type converter).

### Digital input DI (opt.)

Signal type: 20 to 30Vdc voltage signal  
Input resistance: 2.7k $\Omega$   
Number of inputs: one point

**DI function** — One of the following functions can be assigned to the optional DI signal.

**Range switching** — Selects either the higher or lower range in the unidirectional or bidirectional 2-range setting.

**Totalizer control** — Starts and stops the built-in totalizer.

**Fixed-value outputs** — Outputs fixed-values for current and pulse outputs.

**Zero adjustment** — Executes zero adjustment (on-stream at zero flow rate).

### Output signals

#### Current output:

4–20mAdc (load resistance 0 to 750 $\Omega$ )

**Note:** The current output cannot be used with the PROFIBUS-PA communication.

**Digital outputs** — One point (std.) and one more point is optionally available as follows.

#### Digital output DO1 (std.):

Output type: Transistor open collector  
Number of outputs: One point  
Output capacity: 30Vdc, 200mA maximum

#### Digital output DO2 (opt.):

Output type: Solidstate relay output (non polarity)  
Number of outputs: One point  
Output capacity: 150Vdc, 150mA maximum or 150Vac (peak to peak), 100mA maximum

**DO1 and DO2 functions** — One of the following functions can be assigned to DO1 (std.) and/or DO2 (opt.)

- **Pulse output (available only for DO1,DO2)**

Pulse rate: 3.6 to 36,000,000 pulses/hr (DO1)  
3.6 to 360,000 pulses/hr (DO2)

(Over 3,600,000 pulses/hr, auto-setting)

Pulse width: 0.5 to 500ms (but less than half of the period for 100% flow rate)

Note: The same and simultaneous pulse is not available between DO1 and DO2.)

- **Multi-range selection outputs (Note 1)**

- **High, High high, Low, and/or Low low alarm outputs (Note 2)**

- **Empty pipe alarm output**

- **Digital Output Active Status (DO1 and DO2) (Note 2)**

- **Preset count output**

- **Converter failure alarm output**

**Note 1:** Two outputs (DO1 and DO2) are needed for 4-range switching and forward/reverse 2-range switching.

**Note 2:** Normal Open (default set) or Normal Close is selected for alarm outputs when programming.  
When power failure occurs, unit will be fault to Normal Open.

### Communications output:

- **HART (std.)** — Digital signal is superimposed on 4–20mAdc current signal as follows:

Conforms to HART protocol

Load resistance: 240 to 750 $\Omega$

Load capacitance: 0.25 $\mu$ F maximum

Load inductance: 4mH maximum

- **PROFIBUS (opt.)**

Protocol : PROFIBUS-PA

Baud rate : 31.25kbps

Bus voltage : 9-30VDC

Consumption electric current of bus:less than 16mA

Manufacture Ident-No. : 093B<sub>HEX</sub>

Standard Ident-No. : 9740<sub>HEX</sub>

Slave address : 0-126 (Default address is 126)

Profile : Profile Ver.3.01 for Process Control Devices

Function blocks : AI(Flow) $\times$ 1 , Totalizer $\times$ 1

### LCD display: Full dot-matrix 128 $\times$ 128 dot LCD display (back-light provided)

The data on the LCD inside the converter can rotate to 90, 180, and 270 degrees by a software, without rotating the indicator itself. (Combined type only)

**Parameter settings** — Parameters can be set as follows:

- **IR Switches:** Three key switches are provided to set configuration parameters.

- **Digital communication:** The AF900 hand-held terminal or PROFIBUS is needed to set parameters.

- **Zero adjustment:** Zero point adjustment can be started by pressing the switch in the converter.

- **Damping:** 0.5 to 60 seconds (selectable in one second increments)

### “Field re-verification” Mag-Prover – Toshiba’s

Zero span calibration tool allows unit to be re-calibrated and verified using an internal software program. (For more information contact Toshiba International Corp.)

### Conditions when power fails:

Parameter setting values are stored in non-volatile memory and the values will be restored when the power returns to normal condition. The outputs and display will remain as follows when power fails.

- Current output: 0mAdc

- Digital output: OFF
- LCD display: No display
- PROFIBUS: No communication

**Power supply:**

One of the following can be selected:

- 100 to 240Vac, 50/60Hz (std.)  
(allowable voltage 80 to 264Vac)
- 24Vdc (allowable voltage 18 to 36Vdc)
- 110Vdc (allowable voltage 90 to 130Vdc)

**Surge protection:**

Arresters are installed in the power supply, and a current signal output circuit to help protect the meter from lightning and improve personnel safety.

**Case:** Aluminum alloy (equal to IP 67)

**Coating:** Acrylic resin-baked coating, pearl-gray colored

**Cable connection ports:**

**Cable glands —**

LF610 and LF612 without cFMus Approval:

Provided as standard, OD of cable

11~13mm

Material Nylon 66

G (PF) 1/2 male screws.

LF610F and LF612F with cFMus Approval:

Not provided, 1/2–14NPT male screws are required.

**Applicable diameter —**

0.433 to 0.512 inch (11 to 13mm)

**Note:** When PROFIBUS option is specified, cable gland size is  $\phi 6\sim 8$ mm for signal cable,  $\phi 11\sim 13$ mm for power cable

**Vibration resistance:**

No resonance to the following levels of vibration:

- 10 to 150Hz with acceleration of  $9.8\text{m/s}^2$
- Vibration of 30Hz with  $29.4\text{ m/s}^2$  in 4h in each direction will not cause any defect to unit.

**Note:** Avoid using the flowmeter in an environment with constant vibration.

**Dimensions and Weights:**

See Figure 8 (for Separate type)

**MTBF:**

Converter: 220,000 hours (25 years) at 77 °F  
(25 °C) based on strict military specification MIL-HDBK-217F

Detector: 350,000 hours (40 years) at 77 °F  
(25 °C) based on strict military specification MIL-HDBK-217F

## Installation

### ■ Dimensions (Combined type)

#### Clamp connection

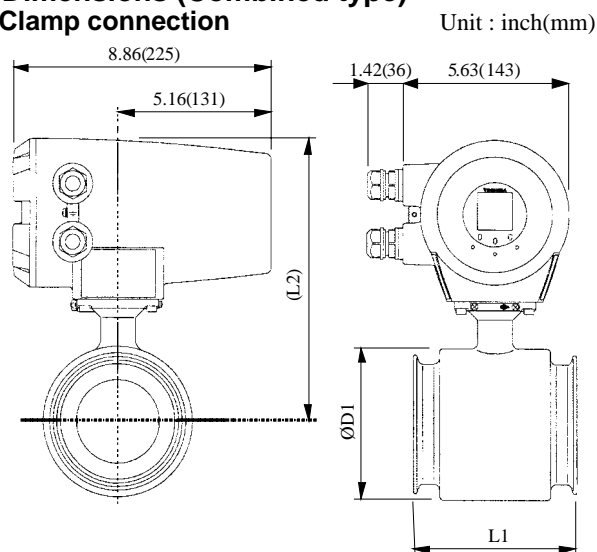

**Note1:** Clamp (Joint) size is different from meter size of LF490 and LF494. See the following table.

**Note2:** Cable glands are not provided for cFMus approved type.

#### Welding connection

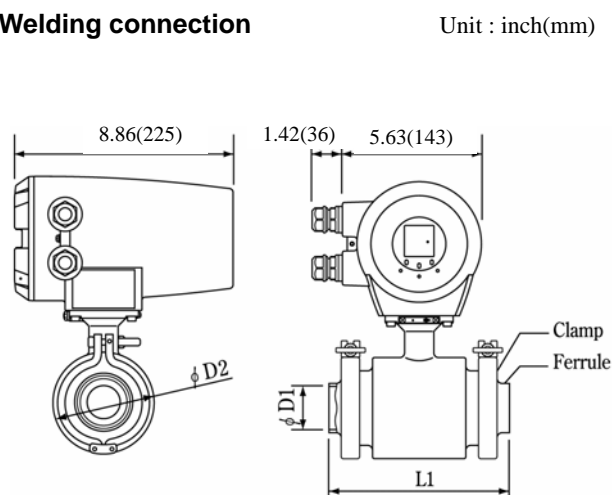

**Note1:** L1 dimension is for the standard (Normal length) type ferrule.

**Note2:** See Figure 7 for Ferrule dimensions.

**Note3:** Cable glands are not provided for cFMus approved type.

For English unit

Meter size (inch)	Joint size (ISO2852)	L1 (inch)	L2 (inch)	D1 (inch)	Weight (lbs)
1 (1S)	2 S	4.33	9.17	2.87	Approx. 11
1-1/2 (1-1/2S)	2 1/2 S	4.92	11.25	3.54	Approx. 13.2
2 (2S)	3 S	5.51	9.64	4.09	Approx. 15.4
3 (3S)	4 S	5.51	10.00	5.12	Approx. 19.8
4 (4S)	5 1/2 S	6.30	10.19	6.38	Approx. 26.5

For SI unit

Meter size mm (inch)	Joint size (ISO2852)	L1 (mm)	L2 (mm)	D1 (mm)	Weight (kg)
25 (1S)	2 S	110	233	73	Approx. 5
40 (1 1/2S)	2 1/2 S	125	286	90	Approx. 6
50 (2S)	3 S	140	245	104	Approx. 7
80 (3S)	4 S	140	254	130	Approx. 9
100 (4S)	5 1/2 S	160	259	162	Approx. 12

**Note:** Tri-clamp® is available to use the same joint size instead of ISO2852 clamp except meter size 100 mm (4").

**Note:** 1 inch = 25.4 mm

**Figure 3. LF490/LF610 and LF494/LF610F Flowmeters (Ferrules and Clamps not attached)**

For English unit

Meter size (inch)	Joint size (ISO2852)	L1 (inch)	D1 (inch)	D2 (inch)	Weight (lbs)
1 (1S)	2 S	6.16	1.00	3.11	Approx. 13.2
1-1/2 (1-1/2S)	2 1/2 S	6.75	1.50	3.66	Approx. 17.6
2 (2S)	3 S	7.34	2.00	4.17	Approx. 19.8
3 (3S)	4 S	7.85	3.00	5.28	Approx. 26.5
4 (4S)	5 1/2 S	8.64	4.00	6.81	Approx. 35.3

For SI unit

Meter size mm (inch)	Joint size (ISO2852)	L1 (mm)	D1 (mm)	D2 (mm)	Weight (kg)
25 (1S)	2 S	156.4	25.4	79	Approx. 6
40(1 1/2S)	2 1/2 S	171.4	38.1	93	Approx. 8
50 (2S)	3 S	186.4	50.8	106	Approx. 9
80 (3S)	4 S	199.4	76.3	134	Approx. 12
100 (4S)	5 1/2 S	219.4	101.6	173	Approx. 16

**Note:** Tri-clamp® is available to use the same joint size instead of ISO2852 clamp except meter size 100 mm (4").

**Note:** 1 inch = 25.4 mm

**Figure 4. LF490/LF610 and LF494/LF610F Flowmeters (Ferrules and Clamps attached)**

**Dimensions (Separate type)**  
Clamp connection

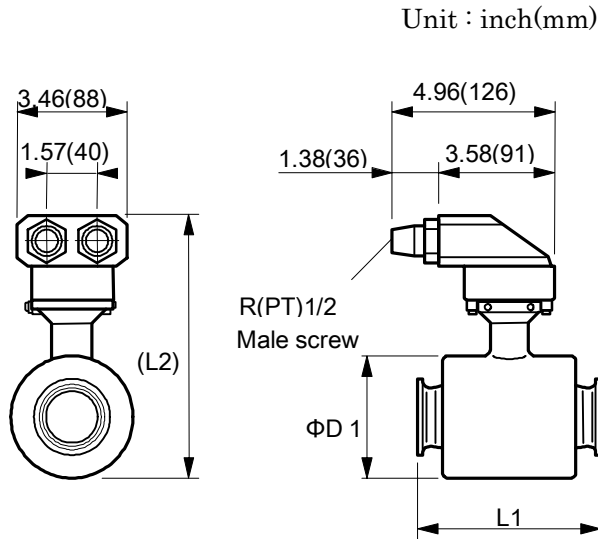

**Note1:** Clamp (Joint) size is different from meter size of LF490. See the following table.  
**Note2:** Cable glands are not provided for cFMus approved type.

For English unit

Meter size (inch)	Joint size (ISO2852)	L1 (inch)	L2 (inch)	D1 (inch)	Weight (lbs)
1 (1S)	2 S	4.33	7.05	2.87	approx. 8.8
1-1/2 (1-1/2S)	2 1/2 S	4.92	7.72	3.54	approx. 11.0
2 (2S)	3 S	5.51	8.27	4.09	approx. 13.2
3 (3S)	4 S	5.51	9.29	5.12	approx. 17.6
4 (4S)	5 1/2 S	6.30	10.55	6.38	approx. 24.3

For SI unit

Meter size (mm)	Joint size (ISO2852)	L1 (mm)	L2 (mm)	D1 (mm)	Weight (kg)
25 (1S)	2 S	110	179	73	approx. 4
40 (1 1/2S)	2 1/2 S	125	196	90	approx. 5
50 (2S)	3 S	140	210	104	approx. 6
80 (3S)	4 S	140	236	130	approx. 8
100 (4S)	5 1/2 S	160	268	162	approx. 11

**Note:** Tri-clamp® is available to use the same joint size instead of ISO2852 clamp except meter size 4" (100 mm).

**Note:** 1 inch = 25.4 mm

**Figure 5. LF490/LF612 and LF494/LF612F Flowmeters (Ferrules and Clamps not attached)**

**Welding connection**

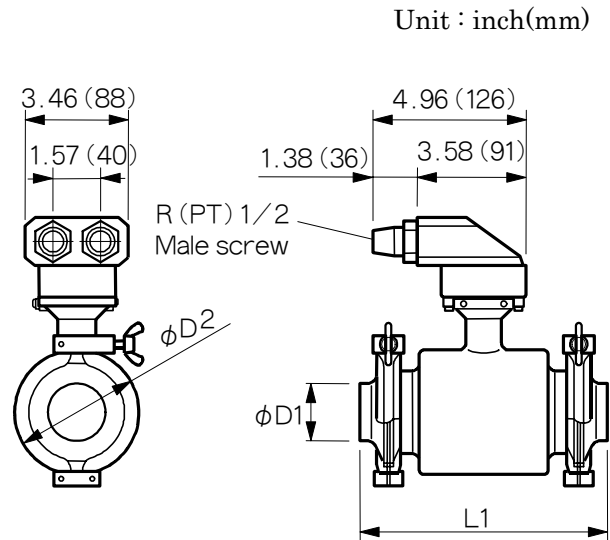

**Note1:** L1 dimension is for the standard (Normal length) type ferrule.  
**Note2:** See Figure 7 for Ferrule dimensions.  
**Note3:** Cable glands are not provided for cFMus approved type.

For English unit

Meter size (inch)	Joint size (ISO2852)	L1 (inch)	D1 (inch)	D2 (inch)	Weight (lbs)
1 (1S)	2 S	6.16	1.00	3.11	approx. 11.0
1-1/2 (1-1/2S)	2 1/2 S	6.75	1.50	3.66	approx. 15.4
2 (2S)	3 S	7.34	2.00	4.17	approx. 17.6
3 (3S)	4 S	7.85	3.00	5.28	approx. 24.3
4 (4S)	5 1/2 S	8.64	4.00	6.81	approx. 33.1

For SI unit

Meter size mm (inch)	Joint size (ISO2852)	L1 (mm)	D1 (mm)	D2 (mm)	Weight (kg)
25 (1S)	2 S	156.4	25.4	79	approx. 5
40 (1 1/2S)	2 1/2 S	171.4	38.1	93	approx. 7
50 (2S)	3 S	186.4	50.8	106	approx. 8
80 (3S)	4 S	199.4	76.3	134	approx. 11
100 (4S)	5 1/2 S	219.4	101.6	173	approx. 15

**Note:** Tri-clamp® is available to use the same joint size instead of ISO2852 clamp except meter size 4" (100 mm).

**Note:** 1 inch = 25.4 mm

**Figure 6. LF490/LF612 and LF494/LF612F Flowmeters (Ferrules and Clamps attached)**

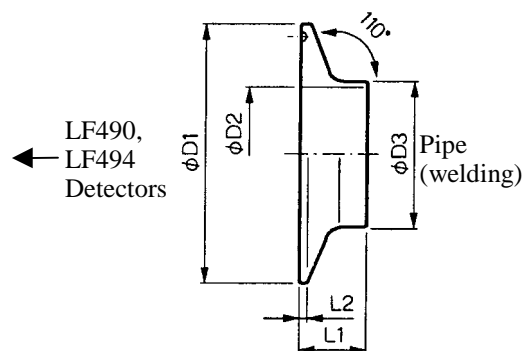

## Normal type For English unit

Meter size (inch)	Joint size (ISO2852)	L1 (inch)	L2 (inch)	D1 (inch)	D2 (inch)	D3 (inch)	Weight (lbs)
1 (1S)	2 S	0.85	0.11	2.52	0.91	1.00	Approx.0.4
1-1/2 (1-1/2S)	2 1/2 S	0.85	0.11	3.05	1.41	1.50	Approx. 0.4
2 (2S)	3 S	0.85	0.11	3.58	1.88	2.00	Approx. 0.7
3 (3S)	4 S	1.10	0.11	4.69	2.85	3.00	Approx. 1.1
4 (4S)	5 1/2S	1.10	0.22	6.10	3.84	4.00	Approx. 2.2

## Normal type For SI unit

Meter size mm (inch)	Joint size (ISO2852)	L1 (mm)	L2 (mm)	D1 (mm)	D2 (mm)	D3 (mm)	Weight (kg)
25 (1S)	2 S	21.5	2.85	64.0	23.0	25.4	Approx. 0.2
40 (1 1/2S)	2 1/2 S	21.5	2.85	77.5	35.7	38.1	Approx. 0.2
50 (2S)	3 S	21.5	2.85	91.0	47.8	50.8	Approx. 0.3
80 (3S)	4 S	28.0	2.85	119.0	72.3	76.3	Approx. 0.5
100 (4S)	5 1/2S	28.0	5.6	155.0	97.6	101.6	Approx. 1.0

## Long type For English unit

Meter size (inch)	Joint size (ISO2852)	L1 (inch)	L2 (inch)	D1 (inch)	D2 (inch)	D3 (inch)	Weight (lbs)
1 (1S)	2 S	3.00	0.11	2.52	0.91	1.00	Approx. 0.4
1-1/2 (1-1/2S)	2 1/2 S	3.00	0.11	3.05	1.41	1.50	Approx. 0.7
2 (2S)	3 S	3.00	0.11	3.58	1.88	2.00	Approx. 0.9
3 (3S)	4 S	4.00	0.11	4.69	2.85	3.00	Approx. 1.8
4 (4S)	5 1/2S	4.00	0.22	6.10	3.84	4.00	Approx. 3.1

## Long type For SI unit

Meter size mm (inch)	Joint size (ISO2852)	L1 (mm)	L2 (mm)	D1 (mm)	D2 (mm)	D3 (mm)	Weight (kg)
25 (1S)	2 S	76.2	2.85	64.0	23.0	25.4	Approx. 0.2
40 (1 1/2S)	2 1/2 S	76.2	2.85	77.5	35.7	38.1	Approx. 0.3
50 (2S)	3 S	76.2	2.85	91.0	47.8	50.8	Approx. 0.4
80 (3S)	4 S	101.6	2.85	119.0	72.3	76.3	Approx. 0.8
100 (4S)	5 1/2S	101.6	5.6	155.0	97.6	101.6	Approx. 1.4

**Note1:** This special Ferrule, which fits on TOSHIBA LF490 and LF494, can be fastened to ISO2852 clamp. Tri-clamp® is available to use the same joint size instead of ISO2852 clamp except meter size 4" (100mm).

**Note2:** "D1" is Toshiba's original dimension.

**Note3:** 1 inch = 25.4 mm

**Figure 7. Ferrule dimensions**

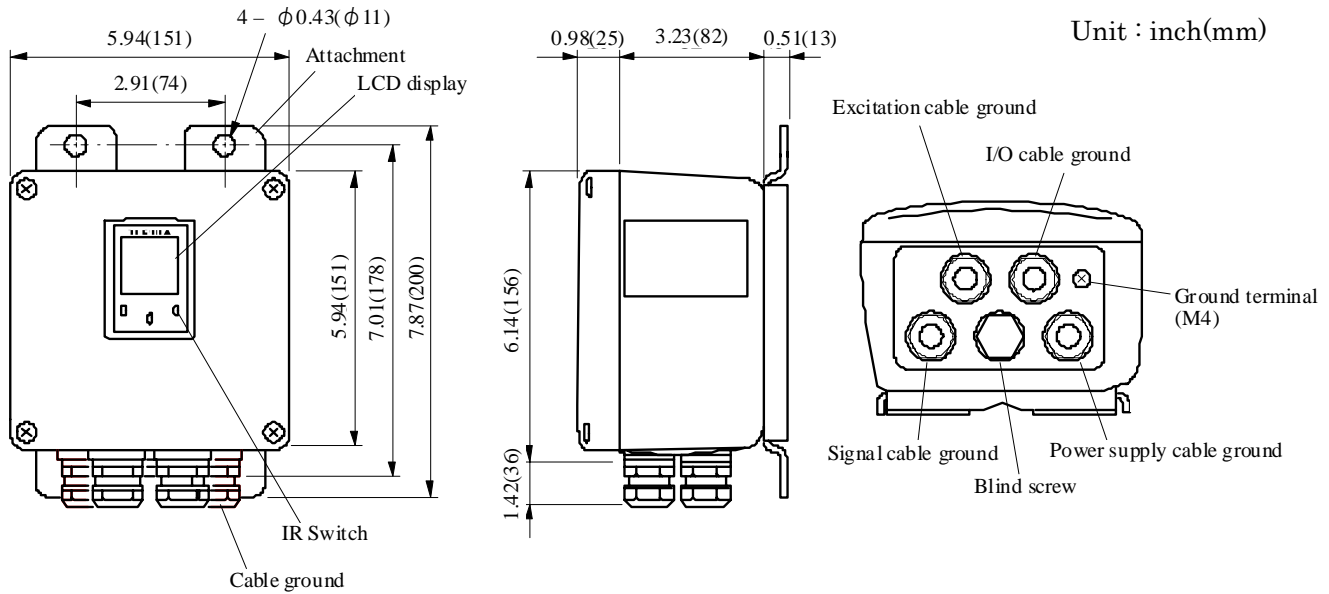
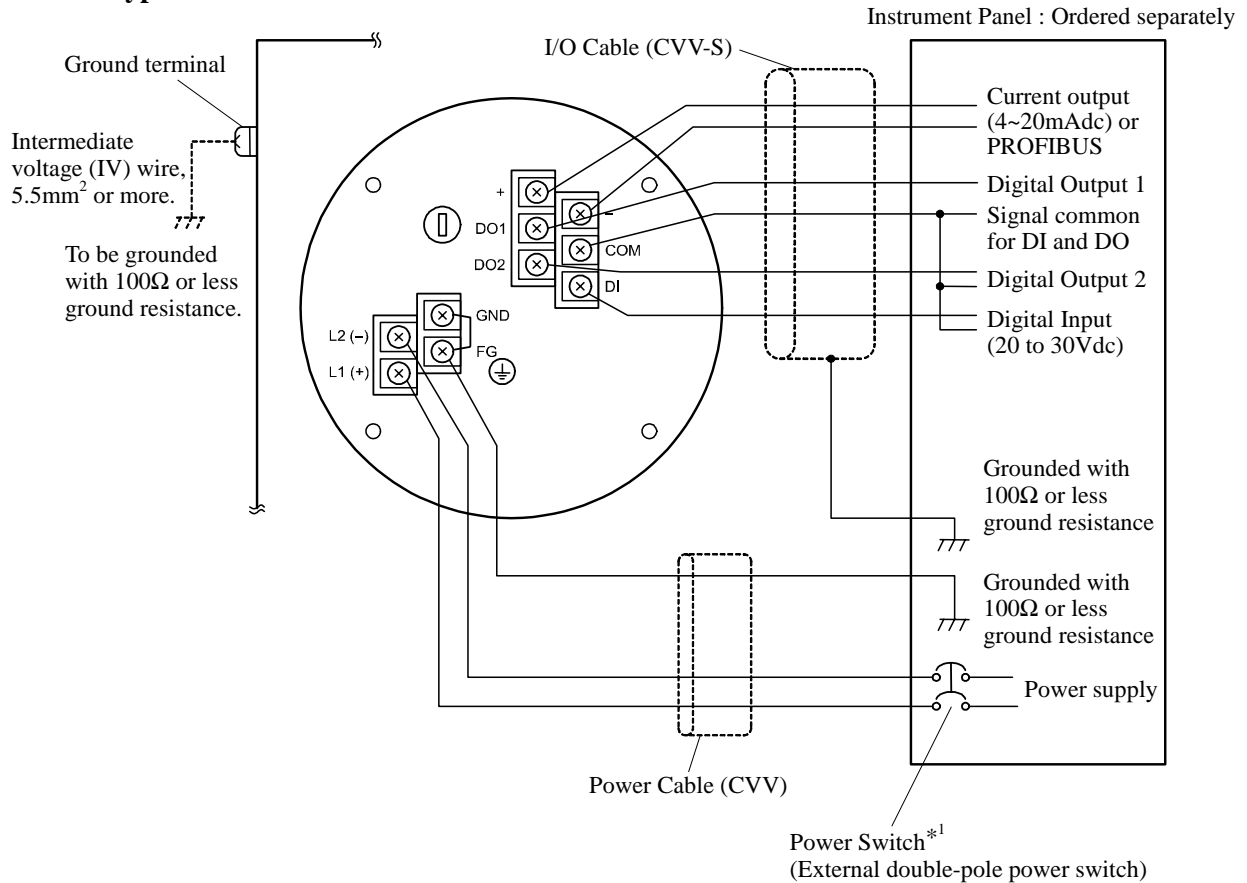

Figure 8. Separate type converter LF612 and LF612F

External Connections

Combined type LF490/LF610 and LF494/LF610F flowmeters



\*1 Locate an external double-pole power switch on the power line near the flowmeter within easy reach of operation. Use the appropriate switch rating as shown below:

Switch rating: 250Vac, 6A or more  
In rush current: 15A or more

Figure 9. Combined type LF490/LF610 and LF494/LF610F flowmeters Wiring Diagram

• Separate type LF490/LF612 and LF494/LF612F flowmeters

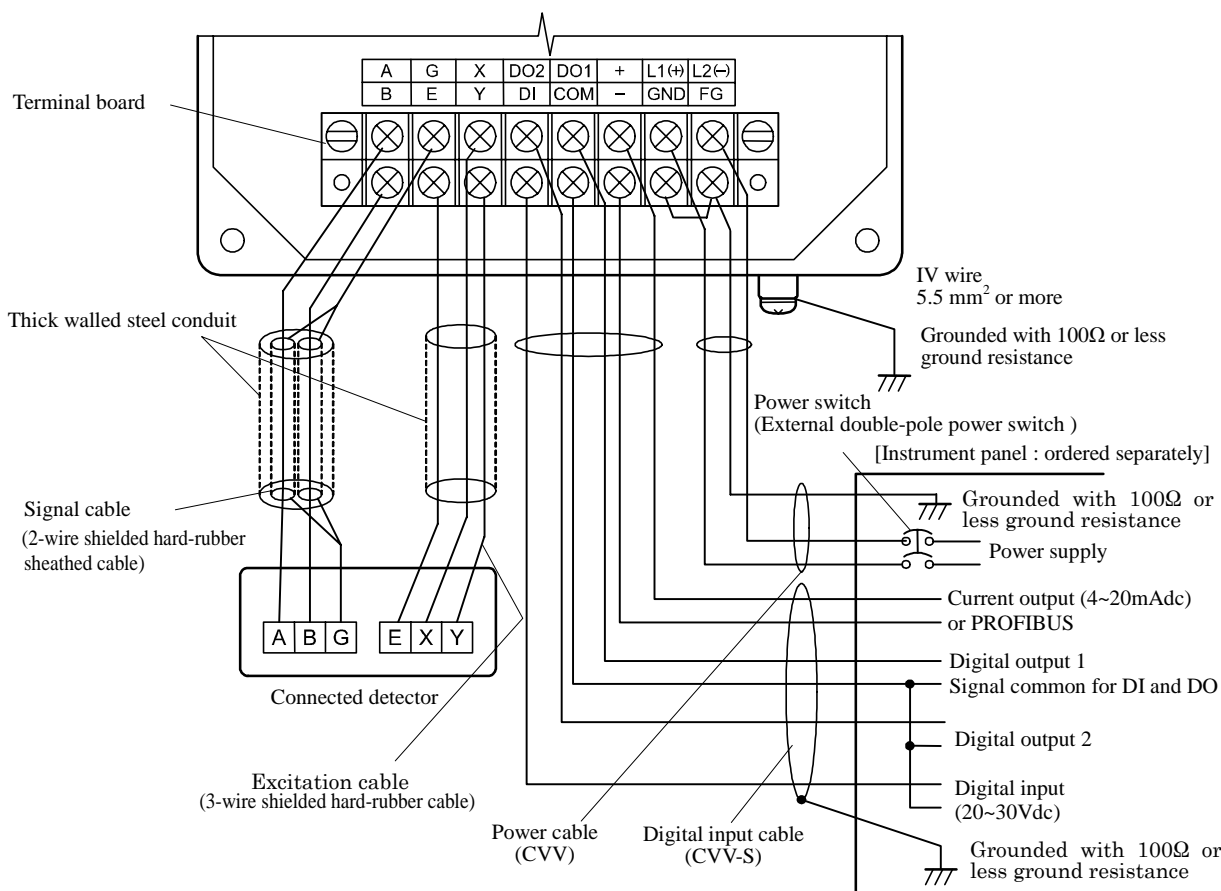

Figure 10. Separate type LF490/LF612 and LF494/LF612F flowmeters wiring Diagram

Table 1. LF610, LF610F, LF612 and LF612F Converters Signal Table

Symbol	Description	Cable
L1 (+)	Power supply	Power cable (CVV)
L2 (-)		
GND	Ground (for arrester)	
FG	Frame ground	
DI	Digital Input (20~30Vdc)	I/O cable (CVV-S)
DO1	Digital Output 1	
DO2	Digital Output 2	
COM	Signal Common for DI, DO1, DO2	
+	Current Output (4~20mA dc) or PROFIBUS	Shielded cable for PROFIBUS-PA
-		
X	Excitation Output	Excitation cable (for LF612, LF612F only)
Y		
E		
A	Signal Input	Signal cable (for LF612, LF612F only)
B		
G		

**Wiring Precautions**

- (1) Explosion proof type flowmeters are not provided cable glands. Refer to the part Cable connection port at detector and converter.
- (2) Connect the grounding wire (IV wire 5.5mm<sup>2</sup> or more) to a good earth ground (100Ω or less ground resistance). Make the wire as short as possible. Do not use a common ground shared with other equipment where earth current may flow. An independent earth ground is recommended.
- (3) The allowable cable lengths between the detector and converter for the separate type flowmeter depend on the electrical conductivity of the object fluid. See Figure 11.
- (4) DO1, DO2 (opt.), and DI (opt.) use the same common terminal (COM). This COM can not connect to other equipments which have their own ground terminal. (Power supply for connecting to DI or DO, etc...) Need to wire separately.

**Wiring Precautions (PROFIBUS)**

- (1) For wiring path, avoid places near electrical equipment that may cause electromagnetic induction or electrostatic induction interference (such as a motor, transformer and wireless transmitter).
- (2) Use a PROFIBUS-PA cable for signal cable. In addition, make sure to use a shielded cable to improve noise resistance. Furthermore, installation of signal cable in metal conduit is recommended.
- (3) General PROFIBUS-PA cables are designed for indoor use where cables are not exposed to humidity, rain, etc. When you install cables, make sure to check the operating conditions such as the operating temperature range of the cable by contacting its manufacturer.
- (4) When you carry out cable end treatment of PROFIBUS-PA cable, use a dedicated cable stripper etc. so that the core wire of the cable will not be nicked or damaged. In addition, for cables, be careful of allowable maximum bend diameter etc. (Basically, do not install cables in a way cables are twisted or bent.).
- (5) Consider installing a PROFIBUS-PA arrester in the communication path of PROFBUS-PA so that the electromagnetic flowmeter will not be affected by lightning etc.
- (6) The electromagnetic flowmeter is not equipped with terminating resistors. Use the terminating resistor unit for PROFIBUS-PA or junction box, if necessary.

- (7) Only one PROFIBUS-PA cable goes through a cable gland of the Electromagnetic Flowmeter. Please use the junction box at system configuration.

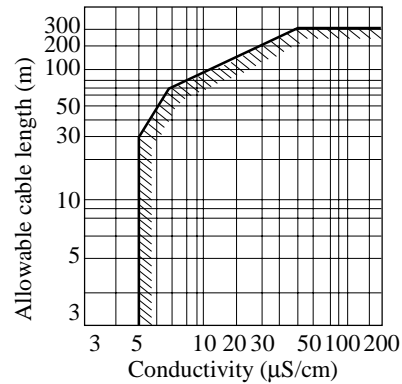

**Figure 11. Electrical Conductivity and Cable Length**

**Meter Size**

**To select the meter size:**

See Table 2 to 3 and find meter sizes within the velocity of 0.3 to 32.8 ft/s (0.1 to 10m/s ) for a specified full-scale (measuring range high limit) flow. Select one that has its full-scale velocity between 3.0 and 10 ft/s (1 and 3m/s).

**Note:** Make sure the full-scale flow rate used for the final planning stage stays within 32.8 ft/s (10m/s) in terms of flow velocity.

**Table 2. Flow Rate and Flow Velocity (English unit)**

Unit: gal/min

Size (inch)	Flow rate				
	0.3ft/s	0.98ft/s	3ft/s	10ft/s	32.8ft/s
1	0.7781	2.334	7.115	23.72	77.81
1 ½	1.992	5.975	18.21	60.71	199.2
2	3.112	9.337	28.46	94.86	311.2
3	7.967	23.90	72.85	242.8	796.7
4	12.45	37.35	113.8	379.4	1,245

**Table 3. Flow Rate and Flow Velocity (SI unit)**

Unit: m<sup>3</sup>/h

Size (mm)	Flow rate				
	0.1 m/s	0.3 m/s	1.0 m/s	3 m/s	10 m/s
25	0.1767	0.5301	1.767	5.301	17.67
40	0.4523	1.357	4.523	13.57	45.23
50	0.7067	2.120	7.067	21.20	70.67
80	1.809	5.428	18.09	54.28	180.9
100	2.827	8.482	28.27	84.82	282.7

## ■ Calibration Range

If the calibration range is not specified, the standard range as shown below will be used. If the range is specified, we will use the specified range for calibration.

**Table 4. Standard Flow Range**

Meter size inch(mm)	Standard flow range		
	Flow rate (gal/min)	Flow rate (m <sup>3</sup> /h)	Flow velocity (m/s)
1 (25)	75	6	3.395
1 1/2 (40)	175	15	3.316
2 (50)	300	25	3.537
3 (80)	650	60	3.316
4 (100)	1,000	100	3.537

**Note:** The unit of "gal/min" is not exchanged (converted) by "m<sup>3</sup>/h".

## ■ About establishment environment

Do not store or install the flowmeter :

- Where there is direct sunlight.
- Where excessive vibration or mechanical shock occurs.
- Where high temperature or high humidity conditions exist.
- Where corrosive atmospheres exist.
- Places that can be submerged under water.
- Where there is a sloped floor. To put the flowmeter temporarily on the floor, place it carefully with something, such as a block, to support it so that the flowmeter will not topple over.

In areas like the following, there may be the case that infrared switches do not function correctly. (If these are unavoidable, use an appropriate cover.)

- (1) Where unit (operation panel) is exposed to direct sunlight, reflection of light onto window pane and diffused light reflection.
- (2) Where smoke and steam may occur.
- (3) Where exposed to direct snow, ice or mud.

## Ordering Information

1. When ordering the LF490 series flowmeters, refer to Tables 5 and 6 (Type Specification Codes). An entry must be made for each of the columns in each of these tables.
2. Fluid characteristics:
  - (1) Type of fluid to be measured and its characteristics
  - (2) Fluid temperature
  - (3) Fluid pressure
  - (4) Electrical conductivity of the fluid
3. Measuring range
4. I/O function setting
5. Ordering scope:
  - Flow calibration data: (required or not)
6. Other items
  - Specifications other than standard items

**Consult a Toshiba representative before ordering when choosing materials of the wetted parts such as lining, electrodes, and grounding rings.**

**Table 5. Specification Code (Sanitary type detector LF490 Series)**

Model					Specification Code										Description	Type	
1	2	3	4	5	6	7	8	9	10	11	12	13	14	Normal		Ex. type	
L	F	4	9	0											Normal specification type	√	
L	F	4	9	4											Hazardous location certification type (Note 1)		√
					E										Meter size (Clamp size)		
					F										1"(25mm) (2S)	√	√
					G										1 1/2"(40mm) (2 1/2S)	√	√
					H										2"(50mm) (3S)	√	√
					J										3"(80mm) (4S)	√	√
															4"(100mm) (5 1/2S)	√	√
					L										Mounting Style		
					M										Detector/Converter combined type (LF490/LF610)	√	
															Detector/Converter separate type (LF490/LF612)	√	
					A										cFMus class I, Division 2 (Note 1)		
					B										Detector/Converter combined type (LF494/LF610F)		√
															Detector/Converter separate type (LF494/LF612F)		√
					A										Connection method		
					Z										Sanitary clamp type (ISO 2852) (Note 2)	●	●
															Other	○	—
					B										Electrode Material (Note 5)		
					Z										316L stainless steel	●	●
															Other	○	—
					S										Lining and Sealing materials (gaskets) (Note 5)		
															Teflon PFA and Silicone rubber	●	●
					A										Piping connection parts (ferrules, clamps) (Note 2, 3, 5)		
					B										No ferrule and no clamp	●	●
					C										Normal type of Ferrules (304 stainless steel) with no clamp	○	○
					D										Normal type of Ferrules (304 stainless steel) with clamp	○	○
					E										Long type of Ferrules (304 stainless steel) with no clamp	○	○
					Z										Long type of Ferrules (304 stainless steel) with clamp	○	○
															Other	○	—
					A										Flow and calibration velocity range		
					B										1.0 to 32.8 ft/s (standard range calibration)	●	●
					C										1.0 to 32.8 ft/s (specified range calibration)	○	○
															0.3 to 32.8 ft/s (specified range calibration)	○	○
					A										Excitation and Signal Cables		
					B										not provided	●	●
					C										30 m cable, provided (Note 4)	○	○
															other lengths, provided (Note 4)	○	○
					A										Coating (Note 6)		
					F										no coating	●	●
					Z										3A approved type	○	—
															Other	○	—

Size code explanation: √ : Object ● : Standard ○ : Option — : Not available

**Note1:** Cable glands are not provided. Refer to the part of "Cable connection port" at detector and converter.

**Note2:** Tri-clamp® is available to use the same joint size instead of ISO2852 clamp except meter size 100mm (4").

**Note3:** Toshiba's original ferrule is required to use for LF490 series detectors to keep just fitting between the joint in case of choosing clamp type.

**Note4:** Applies to the separate type flowmeter only. Specifying the code C, indicate the length of cable from 1 to 300m in 1 meter increments.

**Note5:** Consult Toshiba before ordering when choose materials at the wetting parts.

**Note6:** LF494 have only 3A approved type.

**Table 6. Specification Code for converters**

Model					Specification Code										Contents	LF600 type	LF602 type
1	2	3	4	5	6	7	8	9	10	11	12	13	14				
L	F	6	1												Electromagnetic flowmeter converter		
				0											Combined (Integral) type	●	—
				2											Separate (Remote) type	—	●
					A										Purpose		
					F										Standard	●	●
															cFMus class I, Division 2 approved	○	○
					A										Shape		
					B										Integral type with case	●	—
															Separate type with case	—	●
					A										Converter mounting fitting		
					C										None	●	○
					E										Panel, Accessory for wall mounting (BNP material: SUS304)	—	●
															Accessory for pipe installation (BNP material: SUS304)	—	○
															Digital input/output		
									1						Digital output points 1 (DO1)	●	●
									2						Digital output points 2 (DO1+DO2) +Digital input point 1 (DI)	○	○
															Current output and Communication function		
									1						Current output + HART communication	●	●
									2						PROFIBUS communication (Current output is not usable)	○	○
															Power supply		
									1						100Vac-240Vac, 50/60Hz	●	●
									2						24Vdc	○	○
									3						110Vdc	○	○
															Instruction manual		
														E	English	●	●

Code explanation: ●: Standard ○: Option —: Not available

**Table 7. Type Specification Code for Maintenance Parts**

Meter size inch(mm)	Joint size (ISO2852)	Specification code for maintenance parts			
		Gasket	Ferrule		ISO2852 Clamp
			Normal type	Long type	
1S(25)	2S	3L8A0355P001	3A8A7164P001	3A8A7164P006	4A8A2957P002
1 1/2S(40)	2 1/2S	3L8A0355P002	3A8A7164P002	3A8A7164P007	4A8A2957P003
2S(50)	3S	3L8A0355P003	3A8A7164P003	3A8A7164P008	4A8A2957P004
3S(80)	4S	3L8A0355P004	3A8A7164P004	3A8A7164P009	4A8A2957P006
4S(100)	5 1/2S	3L8A0355P005	3A8A7164P005	3A8A7164P010	4A8A2957P008

**Note1:** A pair of parts are packed in each specification code.

**Note2:** Tri-clamp® is available to use the same joint size instead of ISO2852 clamp except meter size 4"(100mm).