

## PROGRAMMABLE CONTROLLER

# PROSEC T1-16S

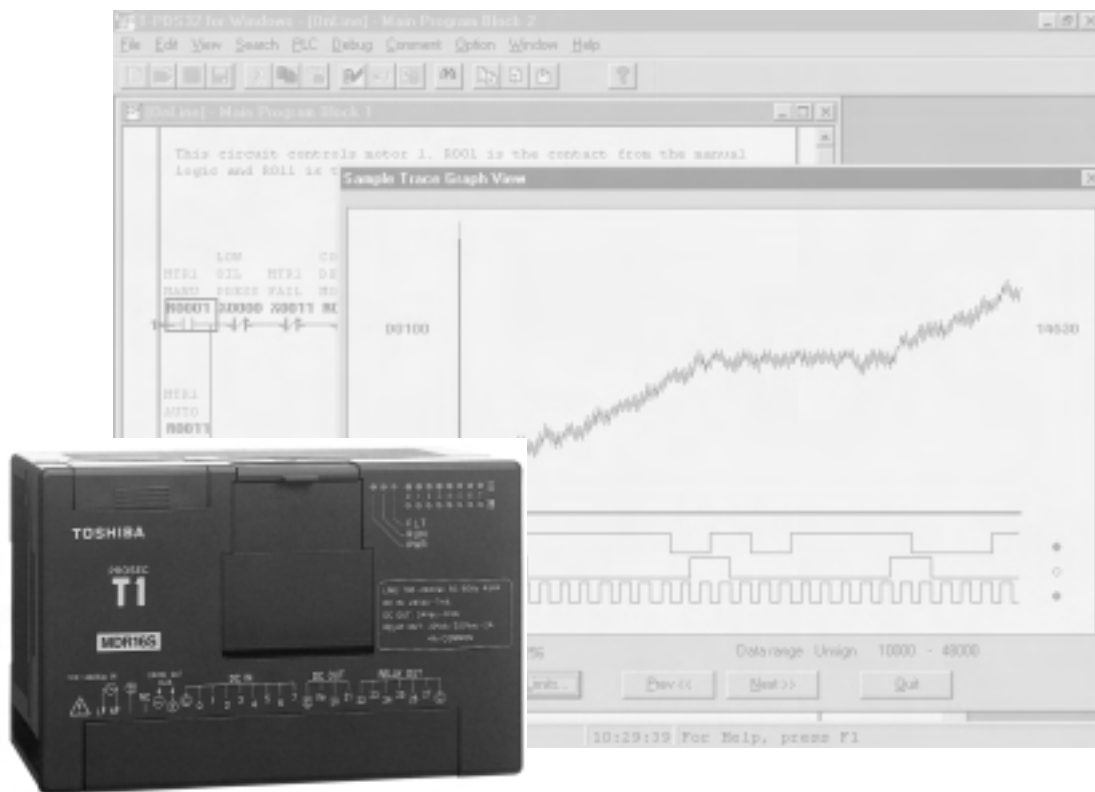

### Advanced Features

- ◆ Compact Modular Style
- ◆ 8K Steps Program Memory
- ◆ Clock/calendar Function
- ◆ Online Program Changes
- ◆ Built-in EEPROM
- ◆ Special Data Transfer Function with Toshiba Inverters (VF-A7/G7/S9)
- ◆ High-Speed Processing
- ◆ RS485 Communication Port
- ◆ High-speed Counter Function
- ◆ Interrupt Input Function
- ◆ Pulse Output Function

# PROSEC T1-16S

## Expandable Micro Programmable Controller

T1-16S is a micro programmable controller with optional add-on expansion I/O modules.

Its communications capability, advanced instruction set, and large memory (program & data register) make it ideally suited for applications previously requiring larger more expensive programmable controllers. The T1-16S's high-speed performance makes it especially adapt at sophisticated machine control applications.

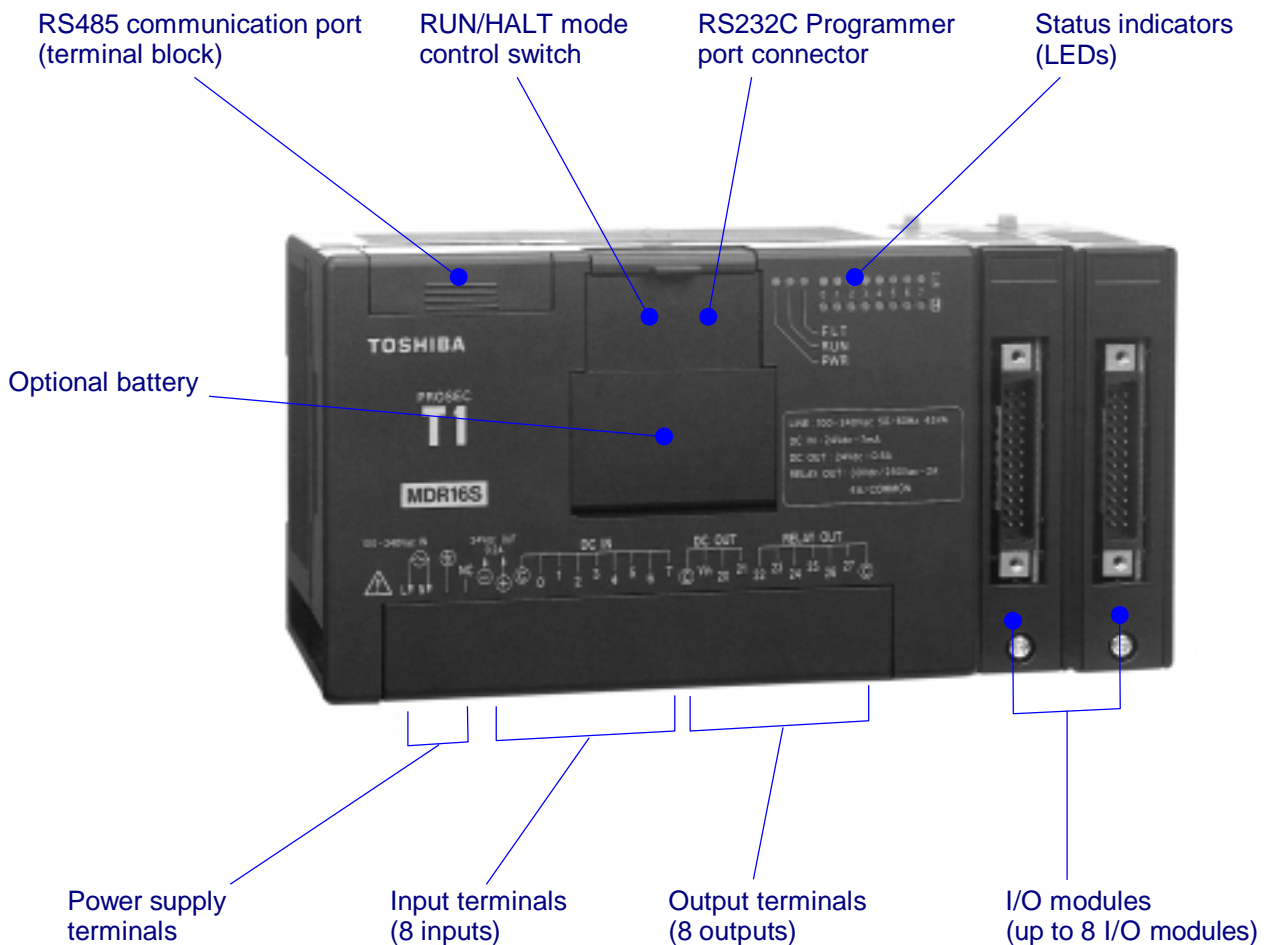

# Memory & Expansion Capacity

The T1-16S is a micro PLC. But it has a large program and data memory.

- ◆ 8192 Steps of Program Memory
- ◆ 4096 Words of Data Registers, 256 Timers, & 256 Counters
- ◆ Discrete I/O 144 Points max

## < Basic configuration >



### Main Unit

(Discrete = 8 inputs & 8 outputs)

## < Expansion configuration >

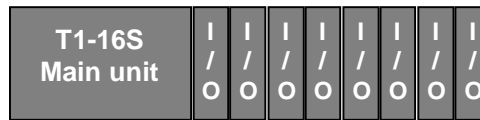

### Main Unit + 8 I/O Modules

(Max Discrete I/O = 16 points + 8 x 16 points = 144 points)

(Max Analog I/O = 8 channels)

Any mix of discrete & analog modules maybe used.

# Execution Speed

Sophisticated machine control applications require high-speed data manipulation. The T1-16S is designed to meet these requirements. The T1-16S is 8 times faster than Toshiba's earlier M20/M40 PLCs.

## < Scan time comparison between T1-16S and Toshiba's M40 >

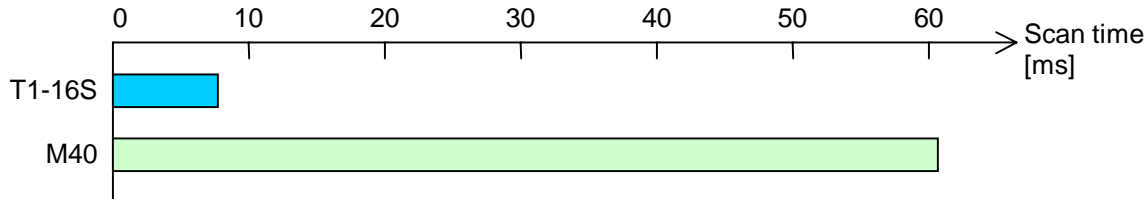

Notes: 1. Actual results of the scan time for a 4K step test program (Including overhead).

The test program consists of:

- 50% of Sequence (Boolean and Timer) Instructions
- 30% of Data Transfer Instructions
- 20% of Arithmetic (Addition, Subtraction and Compare) Instructions

2. The more data transfer & arithmetic instructions used, the faster the T1-16S becomes when compared to other PLCs.

# Performance

The T1-16S offers 21 basic ladder instructions and 97 insert able function instructions. Subroutines, Interrupt functions, Indirect addressing, For/Next loops, Increment/Decrement, Pre-derivative PID, etc. are standard on the T1-16S. These functions allow the T1-16S to be applied to the most complex and demanding control applications.

- ◆ Scan Setting:
  - Floating Scan ... Program scans as fast as possible
  - Constant Scan ... Program executes at a fixed interval (setting: 10 to 200ms)
- ◆ Program Types (Multitasking):
  - 1 Main program, 1 initial program, & 256 Subroutines
  - 1 Timer interrupt program (setting: 5 to 1000ms)
  - 4 I/O interrupt programs (High-speed counter & Interrupt inputs)

# Configuration

## T1-16S Main Unit

There are four types of T1-16S controllers depending on the built-in functions and the power supply voltage.



Type	Description
TDR116S6C	Standard version, 100-240Vac power
TDR116S6S	Enhanced version, 100-240Vac power (with Real-time clock and RS485 port)
TDR116S3C	Standard version, 24Vdc power
TDR116S3S	Enhanced version, 24Vdc power (with Real-time clock and RS485 port)

## I/O Modules

The following types of I/O modules are available. A maximum 8 I/O modules can be connected to each T1-16S controller.



Type	Description
TDI116M*S	16 points 24Vdc input, 5mA (Note)
TDD116M*S	8 points 24Vdc input, 5mA 8 points 24Vdc output, 100mA (Note)
TDO116M*S	16 points 24Vdc output, 100mA (Note)
TRO108M*S	8 points relay output, 240Vac/24Vdc, 1A
TAD121M*S	1 channel analog input, 0 to 5V/0 to 20mA, 12-bit resolution, internal-external isolation
TAD131M*S	1 channel analog input, -10 to 10V, 12-bit resolution, internal-external isolation
TDA121M*S	1 channel analog output, 0 to 20mA, 12-bit resolution, internal-external isolation
TDA131M*S	1 channel analog output, -10 to 10V, 12-bit resolution, internal-external isolation
TTC111M*S	1 channel thermocouple input, type E, J, K, 12-bit resolution, internal-external isolation
TFR112M*S	TOSLINE-F10 remote station, 250K/750Kbps, 1 word input + 1 word output

Note: Cable side connector is not included with the DI, DO, or DD type module. Order connectors separately. (PT15S or PT15F)

# Advanced Applications

## Motion Control

The T1-16S has two high-speed counter inputs. These 5k pps (pulse per second) counters can be used independently (of each other and of the CPU scan) for discrete parts count in applications requiring high-speed compare, reset, and strobe. The counters can also be used together as a quadrature counter to count a 2-phase pulse encoder signal. In the quadrature counter mode, the counting speed is max 20k cps (counts per second). The T1-16S also has a pulse output function (5k pps max). It can generate variable frequency pulse trains CW and CCW. This output can be used to drive a stepper motor. By using these functions together, an inexpensive motion control system can be implemented with the T1-16S.

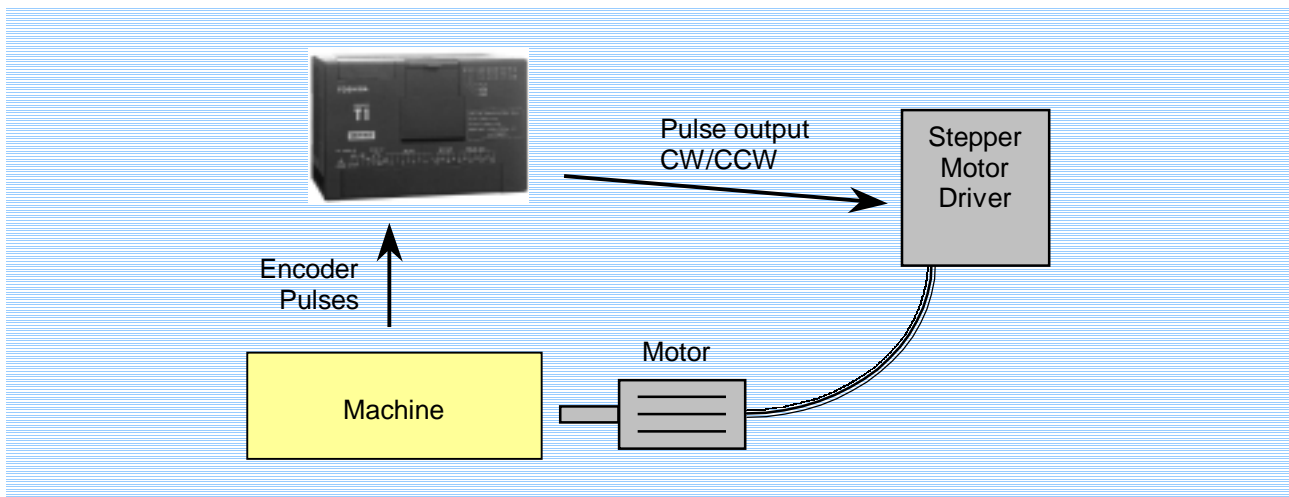

## Process Control

The T1-16S has an advanced PID (Proportional, Integral, and Derivative) control function. This PID function and the analog I/O modules enable the T1-16S to be applied to many process control applications. Multiple PID loops can be used, limited only by the max allowable I/O.

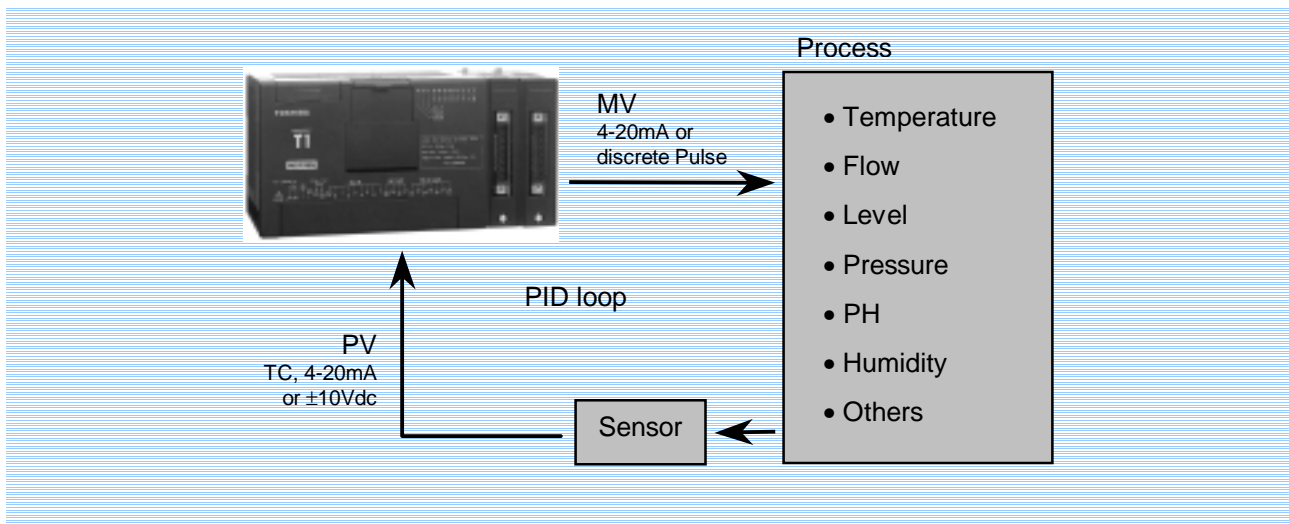

# Communication Features

## SCADA System / Remote Programming

The T1-16S enhanced version has a built-in RS485 communication port. By using this communication port, up to 32 T1-16Ss can communicate with a computer or other higher-level controller. Most major SCADA software supports T-series PLC communication protocol. A DDE server software (T-PSV) is also available.

When using the T-series programming tool (T-PDS) in this configuration, each station can be programmed remotely. A multi-drop adapter (CU111) allows an enhanced T1-16S to have two RS485 ports or for a standard T1-16S to have remote capability added after installation.

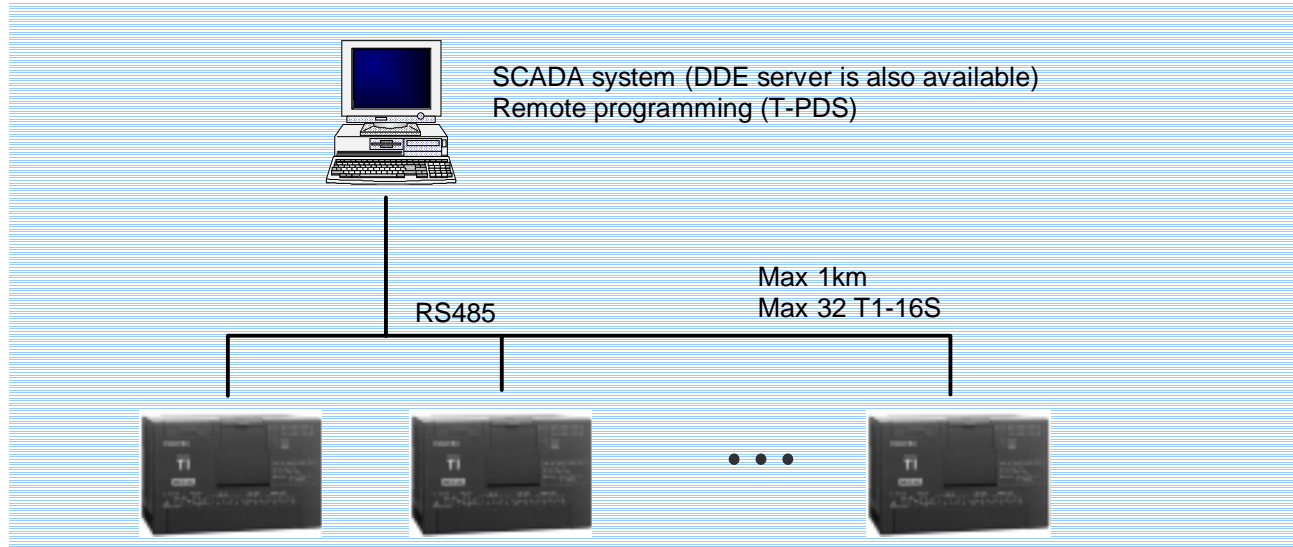

## Easy Data Linkage between Two T1-16Ss

The T1-16S enhanced version's RS485 port supports the data link mode. Using the data link mode, two T1-16Ss can exchange data each other (16 words input and 16 words output). The update cycle for the total 32 words is approx. 50ms. No user program required for this data linkage.

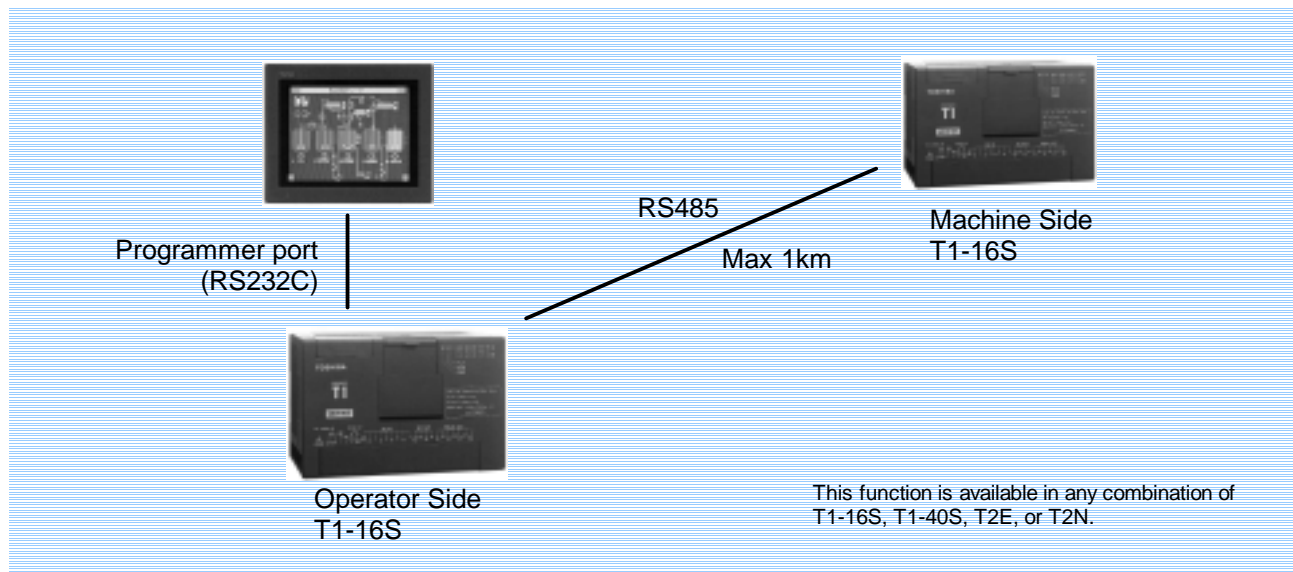

## Flexible Communication Interface

The RS485 port on the T1-16S enhanced version supports a flexible communication function called the Free ASCII mode. This Free ASCII mode lets the T1-16S act as a master to communicate with other field devices that have a serial ASCII communication function. The field devices must support ASCII text communication with fixed trailing code.

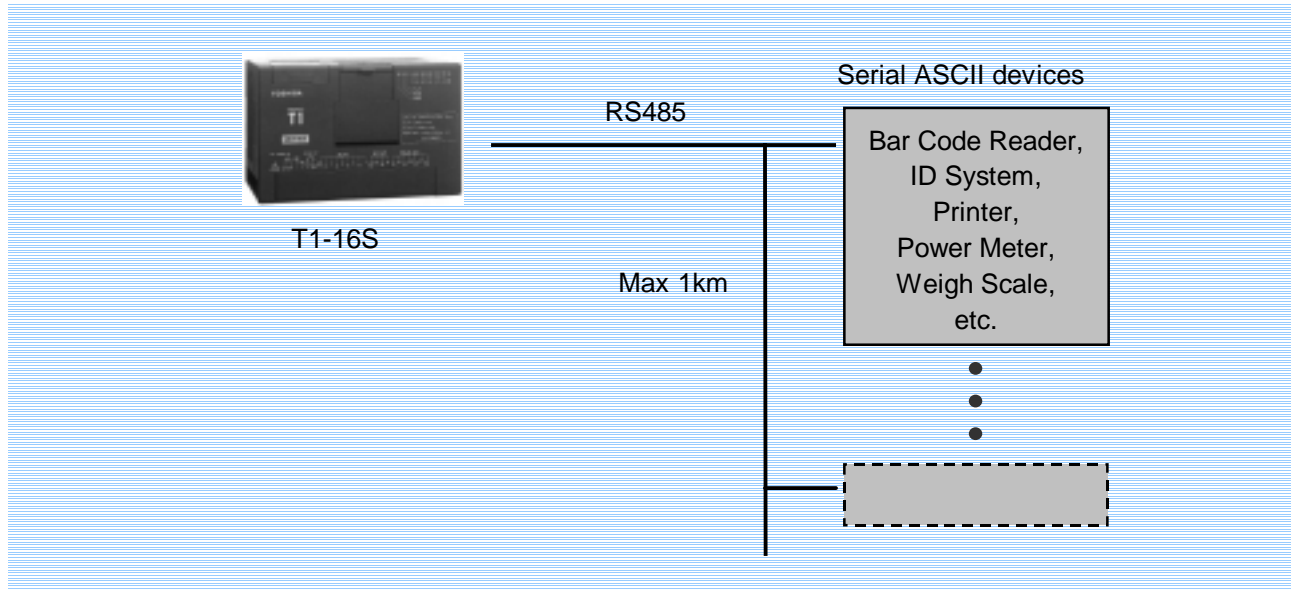

## Easy Connection Inverters (Adjustable Speed Drives)

The RS485 port on the T1-16S enhanced version also supports a special mode to exchange data with Toshiba's Inverters (ASDs), VF-A7/G7/S9. Using this mode, the following data can be sent between the T1-16S and the Inverters without any special communication program.

- ◆ Monitoring – Operation frequency and Terminal status
- ◆ Control – Run/Stop/Jog, Forward/Reverse, Frequency command

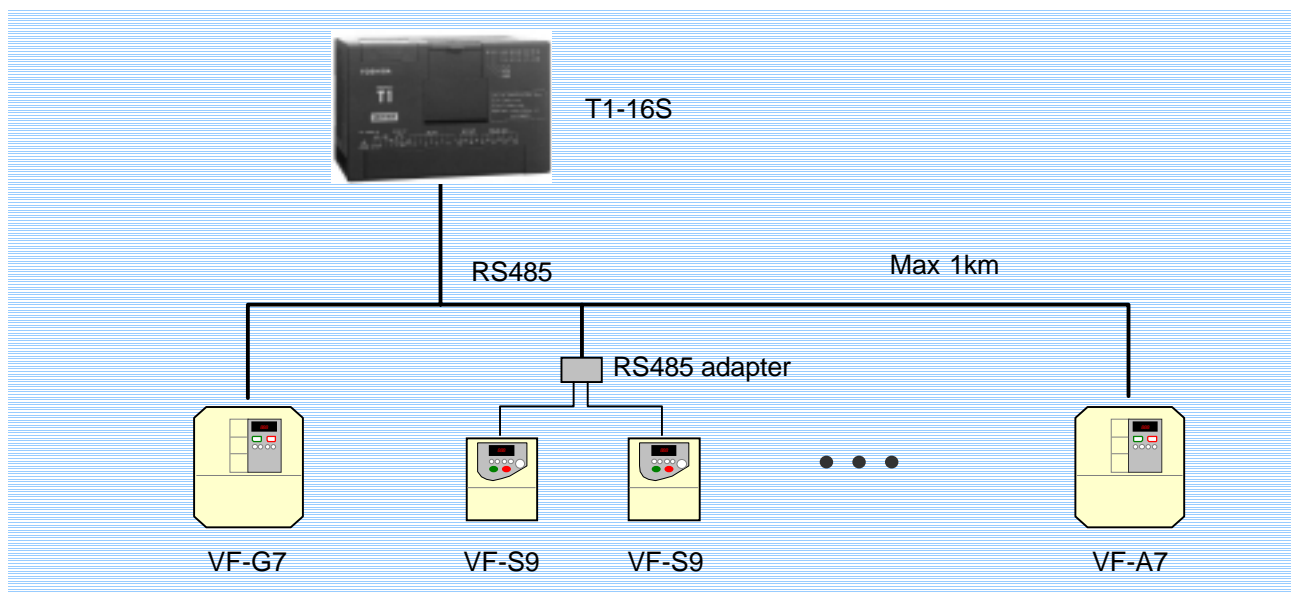

# Programming Tools

## T-series Program Development System (T-PDS)

The T-series Program Development System (T-PDS) is a software program that runs on any Toshiba Notebook computer or other IBM-PC compatible personal computer. The T-PDS software supports on-line/off-line programming, debugging, and program documentation for all T-series programmable controllers; T1/T1S, T2/T2E/T2N, T3/T3H and S2T.

The T-PDS software has:

- ◆ A full-feature program editor that includes cut & paste, search & replace, insert, delete, etc.
- ◆ Program merge, merge blocks from other programs into current program.
- ◆ Load, save and compare of programs between disk file and CPU.
- ◆ Monitor power-flow status of on-line ladder program and display of register values.
- ◆ Sampling trace screen for checking event time relationships.
- ◆ Device force and device set/reset from keyboard.
- ◆ Document programs with tags and commentary.
- ◆ Print map options such as register values, register/device usage, full cross-reference, etc.
- ◆ Built-in Modem Initialize and Dial-up for remote maintenance.



Requires Windows 95 or higher



Program edit screen

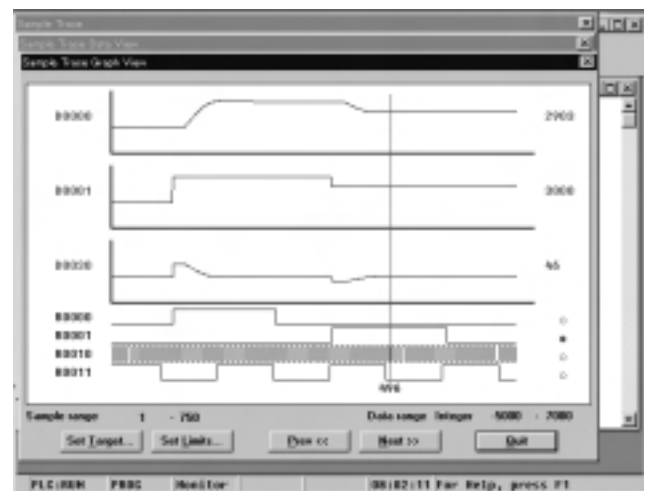

Sampling trace screen

Note)

For the T1-16S, the following T-PDS versions are required.

- T-PDS (Windows) ... Ver 1.2 or later
- T-PDS (MS-DOS) ... Ver 2.1 or later

## Handy Programmer (HP911A)



Note:  
Some T1-16S functions are limited with using the HP911A.

The HP911A is a hand-held graphic programmer. Its portability makes it ideal for maintenance use at remote locations. The HP911A has all the features of a full size programming terminal. (2 m cable for T1-16S is included)

- ◆ Ladder logic programming of T-series programmable controllers T1/T1S, T2/T2E/T2N and T3. (other than T3H and S2T)
- ◆ Built-in EEPROM allows program copy between T-series controllers.
- ◆ Two display modes,
  - Normal: 5 lines and 12 columns
  - Zoom: Full device description
- ◆ Data monitor for I/O and internal registers.
- ◆ On-line data set & I/O force.
- ◆ Backlit LCD display for better operation in dim light.

## Program Storage Module (RM102)



The RM102 is an external memory device, which can store T-series ladder logic programs for T1/T1S, T2/T2E/T2N, T3/T3H and S2T controllers.

By using the RM102, program transfer from a master T1-16S can be easily done without the need for a computer or hand held programmer. Two-button operation makes program load/save accessible for anyone. However, if a password is used in the T1-16S, the password in the RM102 must match before a program load can be executed.

## Multi-drop Adapter (CU111)



The CU111 is an RS232C/RS485 converter, which enables the T1/T1S programmer port to be linked with a master computer. By using the CU111, up to 32 T1/T1Ss can be connected to a master computer or higher level controller. The T1-16S standard version (without built-in RS485 port) can be linked via RS485 using the CU111. The master computer can run a SCADA, HMI or DDE Server software. The T-PDS programming software can also be used through the RS485 link to program or monitor each individual T1/T1S. (see diagram on page 6)

# Instruction Set

## Basic Instructions

Symbol	Name
-   -	NO contact
-  /  -	NC contact
-  ↑  -	Transitional contact (rising edge)
-  ↓  -	Transitional contact (falling edge)
-( )-	Coil
* ( )-	Forced coil (debugging purpose only)
-  I  -	Inverter
-( I )-	Invert coil
-  P  -	Positive pulse contact
-  N  -	Negative pulse contact
-( P )-	Positive pulse coil
-( N )-	Negative pulse coil
MCS	Master control set
MCR	Master control reset
JCS	Jump control set
JCR	Jump control reset
TON	ON delay timer
TOF	OFF delay timer
SS	Single-shot timer
CNT	Counter
END	End

## Function Instructions

FUN No.	Symbol	Name
18	MOV	Data transfer
19	DMOV	Double-word data transfer
20	NOT	Invert transfer
22	XCHG	Exchange
24	TINZ	Table initialize
25	TMOV	Table block transfer
26	TNOT	Table invert transfer
27	+	Addition
28	-	Subtraction
29	*	Multiplication
30	/	Division
31	D+	Double-word addition
32	D-	Double-word subtraction
35	+C	Addition with carry
36	-C	Subtraction with carry
39	U*	Unsigned multiplication
40	U/	Unsigned division
41	DIV	Unsigned double/single division
43	+1	Increment
45	-1	Decrement
48	AND	AND
50	OR	OR
52	EOR	Exclusive OR
56	MAVE	Moving average
61	DFL	Digital filter
62	HTOA	HEX to ASCII conversion
63	ATOH	ASCII to HEX conversion
64	TEST	Bit test
68	SHR1	1 bit shift right
69	SHL1	1 bit shift left
70	SHRn	n bits shift right
71	SHLn	n bits shift left
74	SR	Shift register
75	DSR	Bi-directional shift register

## Function Instructions

FUN No.	Symbol	Name
78	RTR1	1 bit rotate right
79	RTL1	1 bit rotate left
80	RTRn	n bits rotate right
81	RTLn	n bits rotate left
90	MPX	Multiplexer
91	DPX	Demultiplexer
96	>	Greater than
97	>=	Greater than or equal
98	=	Equal
99	<>	Not equal
100	<	Less than
101	<=	Less than or equal
102	D>	Double-word greater than
103	D>=	Double-word greater than or equal
104	D=	Double-word equal
105	D<>	Double-word not equal
106	D<	Double-word less than
107	D<=	Double-word less than or equal
108	U>	Unsigned greater than
109	U>=	Unsigned greater than or equal
110	U=	Unsigned equal
111	U<>	Unsigned not equal
112	U<	Unsigned less than
113	U<=	Unsigned less than or equal
114	SET	Device / register set
115	RST	Device / register reset
118	SETC	Set carry
119	RSTC	Reset carry
120	ENC	Encode
121	DEC	Decode
122	BC	Bit count

FUN No.	Symbol	Name
128	CALL	Subroutine call
129	RET	Subroutine return
132	FOR	FOR-NEXT loop (FOR)
133	NEXT	FOR-NEXT loop (NEXT)
137	SUBR	Subroutine entry
140	EI	Enable interrupt
141	DI	Disable interrupt
142	IRET	Interrupt return
143	WDT	Watchdog timer reset
144	STIZ	Step sequence initialization
145	STIN	Step sequence input
146	STOT	Step sequence output
147	F/F	Flip flop
149	U/D	Up / down counter
154	CLND	Calendar set
155	CLDS	Calendar operation
156	PID3	Pre-derivative real PID
160	UL	Upper limit
161	LL	Lower limit
162	MAX	Maximum value
163	MIN	Minimum value
164	AVE	Average value
165	FG	Function generator
180	ABS	Absolute value
182	NEG	Two's complement
183	DNEG	Double-word two's complement
185	7SEG	7-segment decode
186	ASC	ASCII conversion
188	BIN	Binary conversion
190	BCD	BCD conversion
235	I/O	Direct input / output
236	XFER	Expanded data transfer

# Specifications

## Functional specifications

Model	T1-16S Standard version	T1-16S Enhanced version
Control method	Stored program, cyclic scan system	
Scan system	Floating scan or constant scan (10 to 200ms, 10ms units)	
I/O update	Batch I/O refresh (direct I/O instruction available)	
Program memory	RAM (capacitor back-up) and EEPROM (no back-up battery required)	
RAM memory buck-up	1 hour at 25°C by built-in capacitor, 2 years at 25°C by optional battery	
Program capacity	8K steps (4K or 8K mode)	
Programming language	Ladder diagram with function block	
Instructions	Basic: 21, Function: 97	
Execution speed	1.4µs/contact, 2.3µs/coil, 4.2µs/16-bit transfer, 6.5µs/16-bit addition	
Program types	1 main program 1 sub-program (initial program) 1 timer interrupt (interval: 5 to 1000ms, 5ms units) 4 I/O interrupt (high-speed counter and interrupt input) 256 subroutines (up to 3 levels of nesting)	
I/O capacity	Main unit: 16 points (8 inputs/8 outputs) Expansion I/O: Up to 8 I/O modules (expandable up to 144 points)	
User data	I/O register	512 points/32 words (X/XW, Y/YW)
	Auxiliary relay	4096 points/256 words (R/RW)
	Special relay	1024 points/64 words (S/SW)
	Timer	256 points (T./T), 64 @ 0.01s & 192 @ 0.1s
	Counter	256 points (C./C)
	Data register	4096 words (D)
	Index register	3 words (I, J, K)
Real-time-clock/calendar	No	Yes, (±60s/month)
Special I/O functions	High speed counter (2 single or 1 quadrature) or Interrupt input (2 points), Adjustable analog register (2 points), Pulse output (CW+CCW or pulse+direction) or PWM output	
Communications interface	1 port of RS232C (programmer port) ... Programmer or Computer link protocol	
	-	1 port of RS485 - Computer link mode (Programmer or Computer), - Data link mode, - Free ASCII mode, - Inverter (VF-A7/S9) connection mode
Debug support function	TOSLINE-F10 remote (by using TOSLINE-F10 module)	
	Sampling trace (8 devices and 3 register - 256 times)	
	On-line programming (at 4K mode)	
	On-line EEPROM write	

## General specifications

Model	T1-16S AC power type	T1-16S DC power type
Power supply voltage	100 to 240Vac (+10%, -15%), 50/60 Hz	24Vdc (+20%, -15%)
Power consumption	45 VA or less	18 W or less
Retentive power interruption	10 ms or less	
Internal 5Vdc power output	Max. 1.5A for I/O modules (when 24Vdc service power is not used)	
24Vdc service power output	Max. 0.2A	None
Withstand voltage	1500Vac for 1 minute (between power terminals and ground terminal)	
Ambient temperature	0 to 55°C (operation), -20 to 75°C (storage)	
Ambient humidity	5 to 95% RH, no condensation	
Noise immunity	1000V p-p/1μs, 89/336/EEC (EMC directive)	
Vibration immunity	9.8m/s <sup>2</sup> (1g), (for 30 minutes per axis, on 3 mutually perpendicular axis)	
Shock immunity	98m/s <sup>2</sup> (10g), (3 shocks per axis, on 3 mutually perpendicular axis)	
Standard	UL/c-UL, CE	

## External Dimensions

### ◆ T1-16S main unit

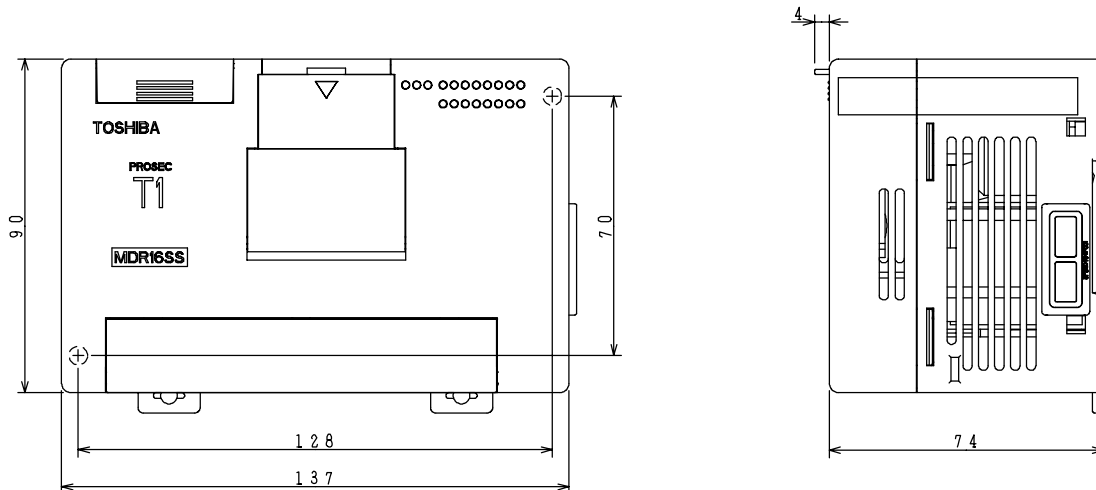

### ◆ I/O module

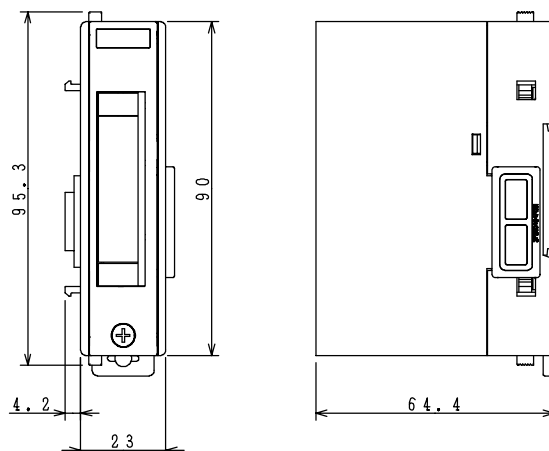

[mm]

## Input/Output specifications

### T1-16S main unit

Model		T1-16S main unit	
Input	Input points	8 points (8 points/common)	
	Rated input voltage	24Vdc, +10/-15 %	
	Rated input current	7mA (at 24Vdc)	
	Min. ON voltage	15Vdc	
	Max. OFF voltage	5Vdc	
	ON/OFF delay time	0 to 15ms (user selectable, default setting is 10ms)	
Output	Relay output	Output points	6 points (6 points/common)
		Rated load voltage	240Vac/24Vdc (max.)
		Max. load current	2A/point (resistive), 4A/common
		Leak current at OFF	None
		Minimum load	5Vdc - 10mA (50mW)
		ON/OFF delay time	10ms or less
	DC output	Output points	2 points (2 points/common)
		Rated load voltage	24Vdc
		Max. load current	0.5A/point (resistive)
		Leak current at OFF	0.1mA or less
		ON/OFF delay time	0.1ms or less
		External connection	Terminal block (fixed), M3 screw

### I/O modules

Discrete I/O		TDI116M*S	TDD116M*S	TDO116M*S	TRO108M*S
Input	Input type	DC input, current sink/source		-	-
	Input points	16 points (8p/com)	8 points (8p/com)		
	Rated input voltage	24Vdc, +10/-15%	24Vdc, +10/-15%		
	Rated input current	5mA	5mA		
	Min. ON voltage	18Vdc	18Vdc		
	Max. OFF voltage	6Vdc	6Vdc		
	ON/OFF delay time	10ms or less	10ms or less		
Output	Output type	-	Transistor output, current sink	-	Relay output
	Output points	-	8 points (8p/com)	16 points (8p/com)	8 points (8p/com)
	Rated load voltage	-	5-24Vdc, +10/-15%	5-24Vdc, +10/-15%	240Vac/24Vdc
	Max. load current	-	0.1A/point	0.1A/point	1A/point (resistive)
	Leak current at OFF	-	0.1mA or less	0.1mA or less	None
	ON/OFF delay time	-	1ms/2ms or less	1ms/2ms or less	10ms or less
External connection	24-pin connector	24-pin connector	24-pin connector	Terminal block	
Current consumption (5Vdc)	50mA	50mA	50mA	260mA	

Analog I/O		TADI21M*S	TAD131M*S	TDA121M*S	TDA131M*S	TTC111M*S
Input	Input type	Analog input	Analog input	-	-	Thermocouple input
	Input points	1 channel	1 channel			1 channel
	Input signal	0-5V/0-20mA	±10V			Type K, J, or E, ±50mV
	Resolution	12-bit (1/4000)	12-bit (1/4000)			12-bit
	Accuracy	±0.5% at 25°C	±0.5% at 25°C			±1% ±1°C
	Conversion cycle	2ms	2ms			20ms
Output	Output type	-	-	Analog output	Analog output	-
	Output points	-	-	1 channel	1 channel	
	Output signal	-	-	0-20mA	±10V	
	Resolution	-	-	12-bit (1/4000)	12-bit (1/4000)	
	Accuracy	-	-	±0.5% at 25°C	±0.5% at 25°C	
	Conversion cycle	-	-	2ms	2ms	
External connection	Terminal block	Terminal block	Terminal block	Terminal block	Terminal block	
Current consumption (5Vdc)	260mA	260mA	350mA	240mA	400mA	

# Ordering Information

Item	Description	Type code	Part number	Remarks
T1-16S main unit	AC power supply, Standard version	T1-MDR16SC	TDR116S6C	
	AC power supply, Enhanced version	T1-MDR16SS	TDR116S6S	
	DC power supply, Standard version	T1-MDR16SCD	TDR116S3C	
	DC power supply, Enhanced version	T1-MDR16SSD	TDR116S3S	
I/O module	16 points DC input	DI116M	TDI116M*S	
	8 points input & 8 points output combo	DD116M	TDD116M*S	
	16 points DC output	DO116M	TDO116M*S	
	8 points relay output	RO108M	TRO108M*S	
	1 channel analog input, 0-5V/0-20mA	AD121M	TAD121M*S	
	1 channel analog input, ±10V	AD131M	TAD131M*S	
	1 channel analog output, 0-20mA	DA121M	TDA121M*S	
	1 channel analog output, ±10V	DA131M	TDA131M*S	
	1 channel thermocouple input, type K, J, E	TC111M	TTC111M*S	
	Data link module	TOSLINE-F10 remote	FR112M	TFR112M*S
DeviceNet slave				UD
Peripheral	Programming tool T-PDS (for MS-DOS)	T-PDS DOS	TMM331SS	
	Programming tool T-PDS (for Windows)	T-PDS32 for Win	TMW33E2SS	
	Handy programmer (w/ 2m cable)	HP911A	THP911A*S	
	Program storage module	RM102	TRM102**S	
	Multi-drop adapter	CU111	TCU111**S	
	DDE server software	T-PSV	TPV33E2SS	
Cable and others	Programming tool T-PDS cable (5m)	CJ105	TCJ105*CS	
	Battery	CR2032	(Commercially available)	
	I/O connector, soldering type (for DI116M, DD116M, DO116M)	PT15S	TPT15S*AS	
	I/O connector, flat cable type (for DI116M, DD116M, DO116M)	PT15F	TPT15F*AS	
	Programmer port connector for computer link (w/ 2m cable)	PT16S	TPT16S*AS	

UD stands for Under development.



Toshiba Corporation's quality management system in design, development and manufacturing of programmable controllers is approved to satisfy the quality management standard ISO9001.