

NAiS

Super-Compact AC Inverters

VFO Series



VFO has come on stage with super-compactness and CE Marking

Single-phase 200V class

0.2kW
0.4kW
0.75kW
1.5kW



Three-phase 400V class

0.75kW
1.5kW
2.2kW
3.7kW



1 Compact

Compactness of the best level has been achieved in response to request for space-saving. Volume is 40 to 56% of previous MEW models. (Width of 400V type excludes installation bracket.)

2 Easy to Operate

Newly applied volume-switch makes operation easier. Forward/reverse run direction can be set with operation panel.



* When parameter P08 data setting is 1.

3 Frequency control with PLC is possible

Frequency control for motors is possible with PWM signal from PLC, without analog I/O units.

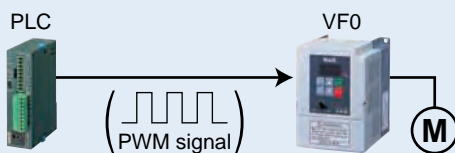

4 High level features despite compact size

- 8-speed control function
- Frequency increase, decrease and memory functions using external switch.
- Complete regeneration brake function.
 - 400V class: built-in brake circuit
 - 200V class: built-in 0.4 to 1.5 kW circuit and resistor (0.2 kW type does not have circuit or resistor. 0.4 kW type is packaged with resistor and installation is external.)
- Retry function

Wiring Diagram

* This diagram is for 3-phase 400 V. The power input terminals for single-phase 200 V class are the two terminals L and N.

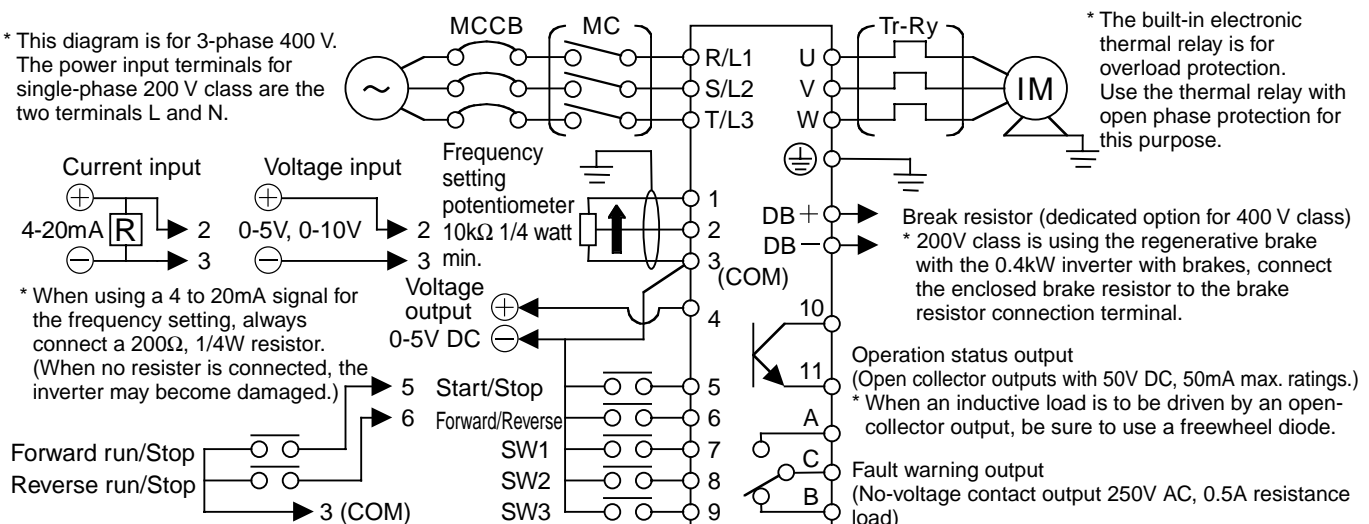

* When shipped it is set for control using the operation panel. Parameter settings will have to be changed depending on the control signals that will be used.

Specifications

Input voltage		Single-phase 200V class	Three-phase 400V class
Applied motor output		0.2 to 1.5 kW	0.75 to 3.7 kW
Rated output	Rated output voltage	3-phase 200 to 230V AC (proportional to power supply voltage)	3-phase 380 to 460V AC (proportional to power supply voltage)
	Overload current rating	150% of rated output current for 1 minute	
Input power supply	Phases, voltage, frequency	Single-phase 200 to 230 VAC 50/60Hz	Three-phase 380 to 460 VAC 50/60Hz
	Tolerable voltage variations	+10%, -15% of rated AC input voltage	
	Tolerable frequency variations	±5% of rated input frequency	
	Instantaneous voltage drop resistance capacity	Continuous operation at 165V or more. Continuous operation at less than 165V for 15ms.	Continuous operation at 323V or more. Continuous operation at less than 323V for 15ms.
Output frequency	Output frequency range	0.5 to 250Hz	
	Frequency display	Digital display	
	Frequency accuracy	±0.5% of selected maximum set frequency (25±10°C) for analog setting	
	Frequency setting resolution	Digital setting: 0.1Hz (1Hz over 100Hz), Analog setting: 0.1Hz (50/60Hz mode)	
Inverter control method		High carrier frequency sinusoidal PWM control (V/F control method)	
Carrier frequency		Select from 9 types (The output current must be reduced for 12.5 and 15.0kHz) (0.8, 1.1, 1.6, 2.5, 5.0, 7.5, 10, 12.5, 15kHz)	Select from 7 types (0.8, 1.1, 1.6, 2.5, 5.0, 7.5, and 10 kHz) (The output current of 3.7 kW must be reduced when set to 10 kHz.)
Operation	Start/Stop	Operation panel buttons or 1a contact signal (wait time setting possible)	
	Forward/Reverse	Operation panel buttons or 1a contact signal (reverse rotation prohibit setting possible)	
	Jog operation	Operating frequency: Optional setting for 0.5 to 250Hz, Acceleration/deceleration time: Optional setting each for 0.04 to 999 seconds	
	Stop mode	Select from ramp-to-stop or coast-to-stop (selection changeover)	
	Reset function	Stop signal reset, external reset, panel reset (setting possible) and power supply reset	
	Stop frequency	Optional setting from 0.5 to 60Hz	
	Instantaneous power failure restart	Function OFF, and 0Hz restart, operating frequency restart (selection changeover)	
	Retry function	Retry selection: Select function OFF and details of retry fault, No. of retries: Optional setting for 1 to 10 times	
Frequency setting signal		<ul style="list-style-type: none"> Local setting: Potentiometer, digital setting (operation panel) External analog setting signal: Potentiometer (10kW, 1/4Ω or more), 0 to 5V, 0 to 10V, 4 to 20mA (Connect a 200Ω, 1/4W or more external resistor) External digital setting signal: PWM signal (signal cycle: 0.9 to 1100ms), Frequency up SW, down SW, save SW signal 	
Voltage/frequency characteristics		Base frequency: 50, 60Hz fixed and optional setting between 45 and 250Hz V/F curve: Constant torque, square torque pattern (selection changeover)	
2nd voltage/frequency characteristics		Optional base frequency setting for 45 to 250Hz	
1st and 2nd torque boost level		Optional setting for 0 to 40%	
1st and 2nd accel./Decel. Time		0.04 to 999 sec. (individual accel. and decel. Time setting), Accel./Decel. Characteristics: Linear	
Multi-speed frequency setting		Up to 8 preset frequency settings (optional setting)	
Skip frequency setting		Up to 3 place settings (skip frequency band setting from 1 to 10Hz)	
Upper and lower frequency setting		Optional setting from 0.5 to 250Hz	
Bias/gain frequency settings		Bias frequency: set from -99 to 250Hz, Gain frequency: set from 0 to 250Hz	
External stop function		Select from auxiliary stop or coast-to-stop (selection setting)	
Braking	Regenerative braking torque	With brakes	0.4kW, 0.75kW, 1.5kW: 100% or more (short-time) 20% or more
		Without brakes	0.2kW: 100% or more, 0.4kW: 80% or more 0.75kW: 20% or more, 1.5kW: 20% or more 100% or more with connection of brake resistor (option) (built-in brake circuit)
DC braking		Operates when less than stop frequency, Braking torque level: 0 to 100 (set between 20 levels), Braking time: Optional setting for 0.1 to 120 seconds	
Analog output		Output specifications: 0 to 5V (max. 1mA), Output functions: Output frequency, output current proportional (selection changeover)	
Open collector output		Output specifications: Max. rating 50VDC, 50mA Output functions: Run signal, arrival signal, overload prealarm, frequency detection, reverse run signal, fault warning, output frequency/current proportional PWM signal (cycle 1ms)	
Relay output		Output specifications: 1c contact (contact capacity 250VAC, 0.5A resistance load) Output functions: Run signal, arrival signal, overload prealarm, frequency detection, reverse run signal, fault warning	
Display	Operating condition	Output frequency or line speed (selection changeover), output current, rotation direction	
	Fault details	Symbol indicated when protective function activates (last 4 faults are stored)	
	Current limit	Current limit can be set from 1 to 200% of rated output current	
Protection	Shut-off (stop)	Instantaneous overcurrent, over temperature (SC1 to 3), overcurrent (OC 1 to 3), overload/electronic thermal overload (OL), low voltage (LU), overvoltage (OU 1 to 3), auxiliary stop (AU), operation error (OP)	
	Stall prevention function	Overcurrent stall prevention, regenerative overvoltage stall prevention	
Environment	Working ambient temperature and humidity	-10°C to +50°C (with no freezing), 90% RH or less (with no dew condensation)	
	Transportation/storage temperature and humidity	-25°C to +65°C, 95% RH or less	
	Altitude and vibration	1000m or less, 5.9m/s ² (0.6G) or less	
	Atmosphere	Indoors, with no corrosive gases, explosive gases, oil mist or dust present	
Enclosure		IP00	
Cooling method		Self-cooling: 0.2 to 0.75kW, Forced-air cooling: 1.5kW	Self-cooling: 0.75kW, Forced-air cooling: 1.5 to 3.7kW

• Protection against Electric shock: Class I • Overvoltage category: II • Pollution degree: 2

Note: The specifications for the 200 V and 400 V classes are not the same. Please keep in mind this partial difference.

Rating

Input voltage	Single-phase 200V class				Three-phase 400V class			
Part No.	1) BFV00022D	BFV00042D BFV00042G	BFV00072D BFV00072G	BFV00152D BFV00152G	BFV00074	BFV00154	BFV00224	BFV00374
Applied motor output (kW)	0.2	0.4	0.75	1.5	0.75	1.5	2.2	3.7
Rated output current (A)	1.4 2)	2.4 2)	3.6 2)	7.0 2)	2.1	3.8	5.4	8.7 3)
Rated output capacity (kVA) 4)	0.6	1.0	1.4	2.8	1.7	3.0	4.3	6.9
Power supply capacity (kVA) 5)	0.7	1.2	1.7	3.7	2.6	3.6	6.4	10.4
Mass (kg)	0.7	0.7	1.2	1.3	1.4	1.4	1.4	2.1

- 1) In the 200 V class part numbers a suffix "D" means there is no brake (no circuit and resistor) and a suffix "G" means there is a brake (0.75 and 1.5 kW: built-in circuit and resistor; 0.4 kW: circuit is built in and resistor is included by installed externally). All of the 400 V class have a built in brake circuit (Brake resistor is an externally installed dedicated option).
- 2) The rated output current for the 200 V class indicates that the carrier frequency is 10 kHz or lower. Please use after reducing the rating to 95% when 12.5 kHz and to 90% when 15 kHz.
- 3) The rated output current 3.7 kW for the 400 V class indicates that the carrier frequency is 7.5 kHz or lower. Please use after reducing the rating to 90% when 10 kHz.
- 4) Regarding the rated output capacity: The 200 V class indicates that the output voltage is 230 V. The 400 V class indicates that the output voltage is 460 V.
- 5) Power supply capacity depends on power supply impedance. It should equal or exceed the capacity specified above.

Dimensions

Single-phase 200V class

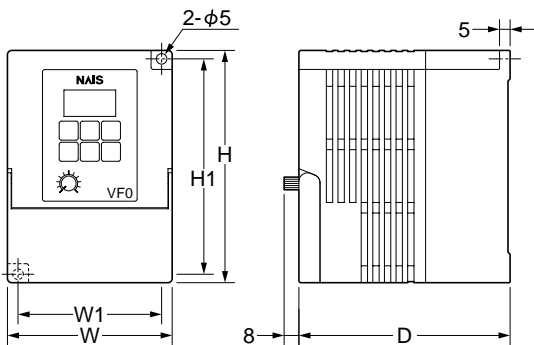

Unit: mm

Inverters capacity (kW)	W	W1	H	H1	D
0.2	78	68	110	102	100
0.4					
0.75	100	90	130	121	115
1.5					

Note 1: 1.5 kW is for the cooling fan.

Three-phase 400V class

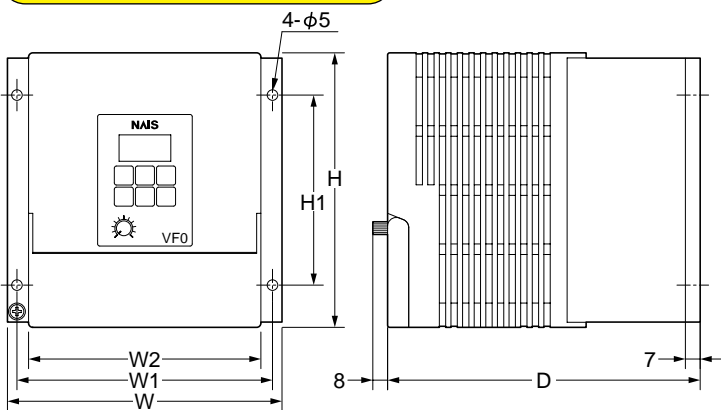

Unit: mm

Inverters capacity (kW)	W	W1	W2	H	H1	D
0.75	130	121	110	130	90	148
1.5	130	121	110	130	90	161
2.2						
3.7	160	151	140	130	90	161

Note 2: 1.5 to 3.7 kW is for the cooling fan.

