

Eliminator™ Series



NCE™
CNCE™
5-7 Eliminator™
5-13 Eliminator™
11-13 Eliminator™

Neutral Current Eliminator™ (NCE™)

Parallel connected, 3-phase, 4-wire passive electromagnetic device that diverts 3rd and other triplen harmonic currents from the neutral conductor.

Combined Neutral Current Eliminator™ (CNCE™)

Series connected, 3-phase, 4-wire passive electromagnetic device that combines NCE™ triplen harmonic filtering with phase shifting for cancellation of 5th and 7th harmonic currents upstream in addition to the 3rd.

5-7, 5-13 & 11-13 Eliminators™

Series connected, 3-phase, 3-wire, phase shifting auto-transformer for control of 5th and 7th or 11th and 13th harmonics in 3-wire circuits (no neutral conductor). Ideal for treatment of 3-phase rectifier harmonics generated by multiple variable frequency drives (VFD's)

Features and Benefits:

- Divert harmonic currents away from neutral and supply transformer
- Reduce voltage distortion caused by harmonic currents
- Reduce high neutral current and neutral-to-ground voltage
- Available field adjustable impedance option (FAI)

- Reduce harmful effect of VFD harmonic currents
- Produce quasi 12, 18 and 24-pulse schemes with multiple 6-pulse VFD's



The Need to Treat Harmonics

Wide use of non-linear loads such as personal computers, monitors, laser printers, variable speed drives, UPS systems and other electronic equipment have led to harmonics being a major issue in the electrical industry today. Commercial and industrial power distribution systems designed for the old, linear-style loads are simply no longer suitable for servicing these non-linear, harmonic generating loads - especially when found in high densities. Some common power system problems include:

1. Overloaded neutral conductors
2. Overheated distribution transformers
3. High neutral-to-ground voltage (V_n-g)
4. Poor power factor
5. Distortion of the voltage waveform supplying these loads.

Power quality problems, particularly those related to high total harmonic voltage distortion (V_{THD}), have been known to cause equipment downtime due to malfunctions and component failure.

The first response by the electrical industry to harmonic problems was to double the neutral conductors and to replace the distribution transformers with K-rated models. Although this brute force method can help survive the overheating situation, it does nothing to address other power quality related problems. Mirus Eliminator™ series harmonic mitigating products, on the other hand, are capable of treating all 5 major symptoms of harmonics.

Eliminator™ Series Products Resolve all 5 Major Symptoms of Harmonics by:

1. Off-loading neutral conductors
2. Lowering losses and reducing operating temperatures in distribution transformers
3. Lowering voltage distortion
4. Lowering neutral-to-ground voltage
5. Improving power factor

Where to use Eliminator™ products

- Any existing distribution system servicing a high density of non-linear loads (ie. PCs and other electronic equipment)
- Older buildings being renovated for new occupancy, especially where half capacity neutrals were used
- Broadcasting and telecommunication equipment rooms
- Computer labs in educational institutions and high tech facilities
- At power panels serviced by long cable runs
- On building risers or busduct runs
- Applications involving multiple 6-pulse variable frequency drives

Non-linear Loads and Harmonics

Non-linear loads draw current in a non-sinusoidal or distorted manner because their impedance changes as the applied voltage changes during an AC power cycle. The most common form of distorted current is a pulsed waveform. Examples of linear and non-linear load current waveforms are shown below.

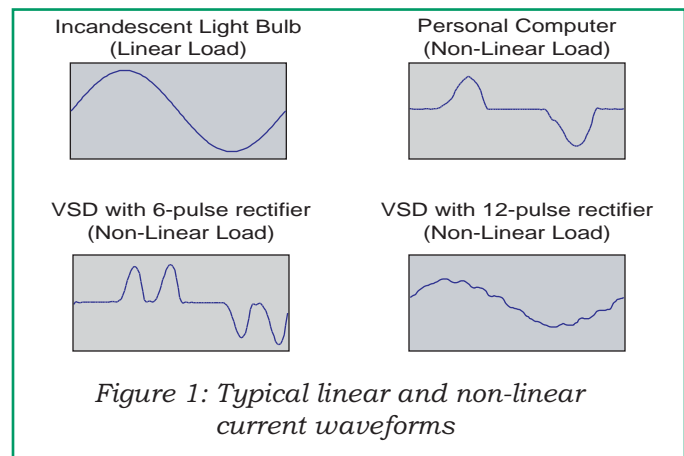

Waveform distortion can also be quantified in the frequency domain by applying a mathematical technique known as Fourier Analysis.

Fourier proved that any periodic non-sinusoidal waveform can be represented as the sum of a series of sinusoidal waveforms at integral magnitudes and phase angles and having certain multiples of the fundamental frequency. These integral multiples are known as harmonics.

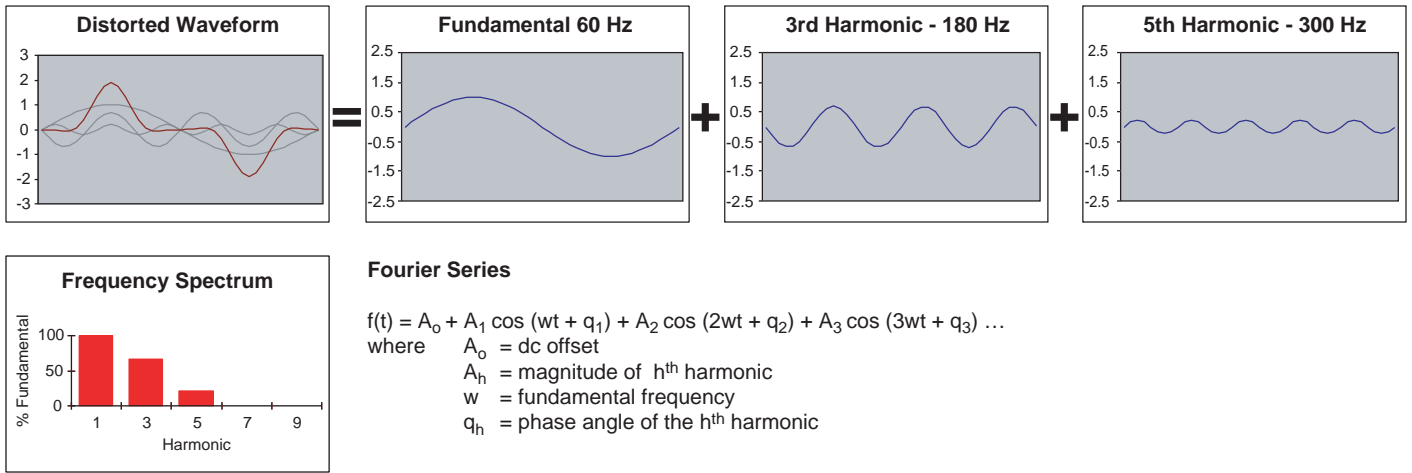

Figure 2: Harmonic Components of a Distorted Waveform

Figure 2 illustrates, a distorted waveform formed by summing each of its sinusoidal components (fundamental 3rd and 5th in this case). This method of reducing the waveform into fundamental and higher frequencies can also be presented as a spectrum in a bar chart showing magnitudes and frequencies, and is known as a frequency or harmonic spectrum.

Current harmonics are currents which flow in the system at various multiples of the fundamental frequency. Similarly voltage harmonics are voltages present in the system at multiples of the fundamental frequency. For example, if we measure voltage at 180Hz in a 60Hz system, there is voltage at the 3rd harmonic (3 x 60Hz = 180Hz). The effects on a power system of distorted currents can be determined by analyzing each harmonic circuit individually and then summing the result. The combination of the fundamental and all harmonic waveforms is an equivalent representation of a distorted or non-sinusoidal waveform.

How 3rd Harmonic Currents add in the Neutral

Figure 3 shows how currents on the phases of a 3-phase, 4-wire system return on the neutral conductor. The 120° phase shift between linear load currents will result in their balanced portions instantaneously canceling in the neutral. With linear loads, the neutral can be the same size as the phase conductors because the neutral current cannot be larger than the largest phase current, even when the load is completely unbalanced.

When the load is non-linear however, the current pulse on one phase will not have a pulse on either of the other phases for which to cancel. The pulses are additive which often leads to heavier

current on the neutral conductor than on any phase conductor. The frequency of this neutral current is primarily 180 Hz (3rd harmonic). This is evident in the waveforms of Figure 3 since the linear current completes only 2 cycles in the same time period that the non-linear neutral current completes 6 cycles or 3 times the fundamental.

With non-linear loads, the neutral current generally exceeds the largest phase current, even when the loads are in perfect RMS current balance.

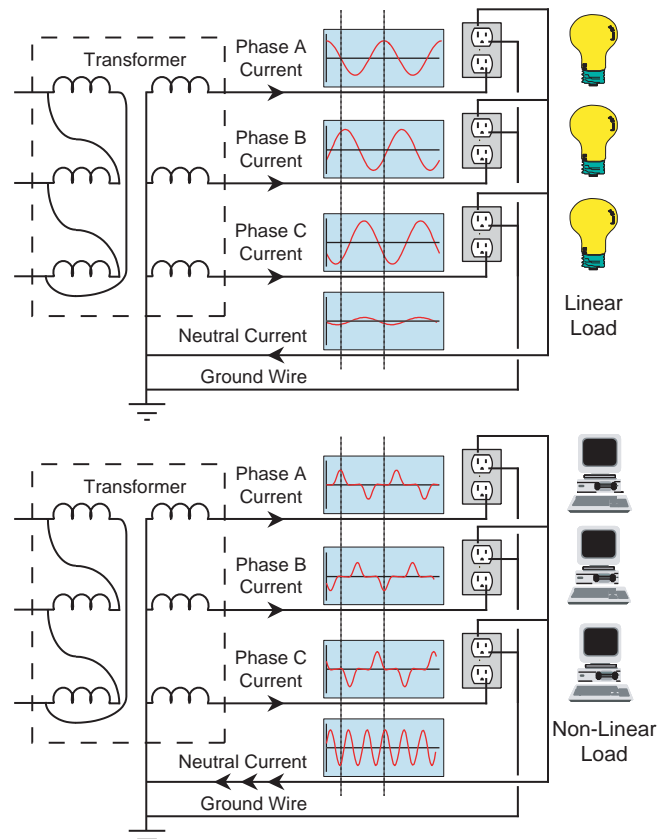

Figure 3: How non-linear load currents add in the neutral

NCE™ off-loads the neutral conductor

The Neutral Current Eliminator™, or NCE™, is a parallel-connected, electromagnetic, zero sequence filter that removes 3rd and 9th harmonic currents as well as other zero sequence currents (I_0) from the neutral conductor. The NCE™ presents a very low impedance alternate path for the neutral current to return to the phases because the windings of the NCE™ are configured to cancel the net flux created by the diverted neutral current. Neutral current, neutral-to-ground voltage, voltage distortion, and supply transformer losses are lowered because there is only a residual amount of 3rd harmonic and other zero sequence currents left in the neutral and phase conductors between the transformer and the NCE™ connection point. Consequently a double ampacity neutral is not required between the supply transformer and the NCE™ connection point.

CNCE™ combines 5th & 7th with 3rd & 9th harmonic mitigation

In many harmonic mitigation applications it is advantageous to treat the 5th and 7th harmonic currents in addition to the 3rd and 9th in order to achieve the maximum reduction in voltage distortion and transformer losses. Our patented CNCE™ is a series-connected, 4-wire auto-transformer that combines the neutral current filtering action of the NCE™ with a 30 degree phase shift in voltage between its input and output.

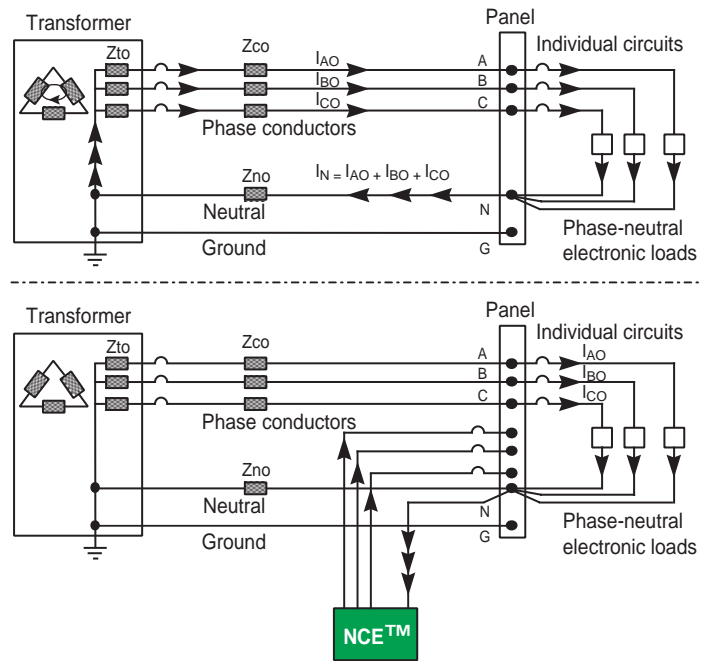
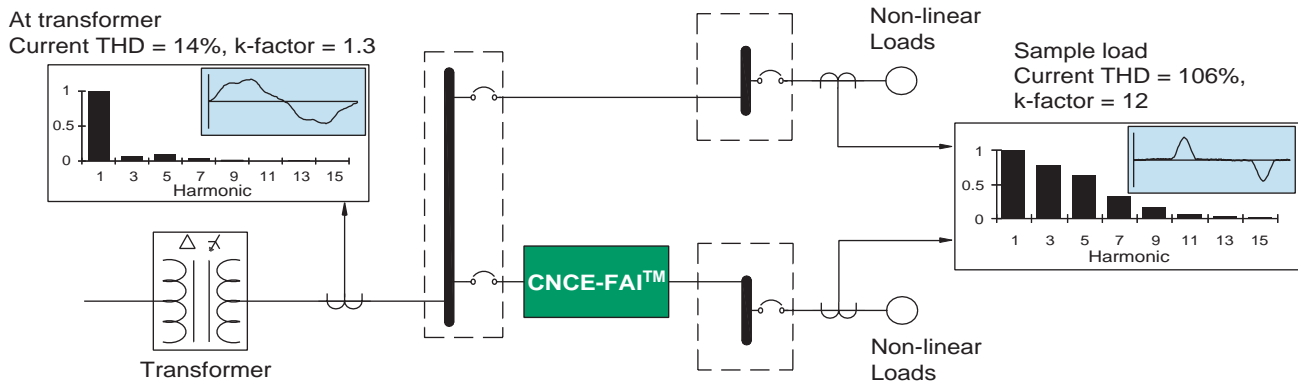

Figure 4: How NCE™ removes 3rd harmonic current from neutral conductor

This phase shift in voltage causes both the 5th and the 7th harmonic currents at the input of the CNCE™ to be 180 degrees out of phase with those created by similar non-linear loads that are fed directly rather than via the CNCE™. In the example below, the CNCE™ makes a dramatic improvement in current distortion, voltage distortion, neutral current, neutral-to-ground voltage, and power factor because it treats all four major harmonic currents (3rd, 5th, 7th, and 9th).



Parameter	Before	After	Performance
Current Distortion	64%	14%	78% reduction
Voltage Distortion	11.1%	2.6%	77% reduction
Feeder Neutral Current	111 A	18 A	84% reduction
Neutral-Ground Voltage	6.04	1.6	74% reduction
Power Factor	0.76	0.95	25% improvement

Figure 5: Typical current distortion improvement using CNCE™

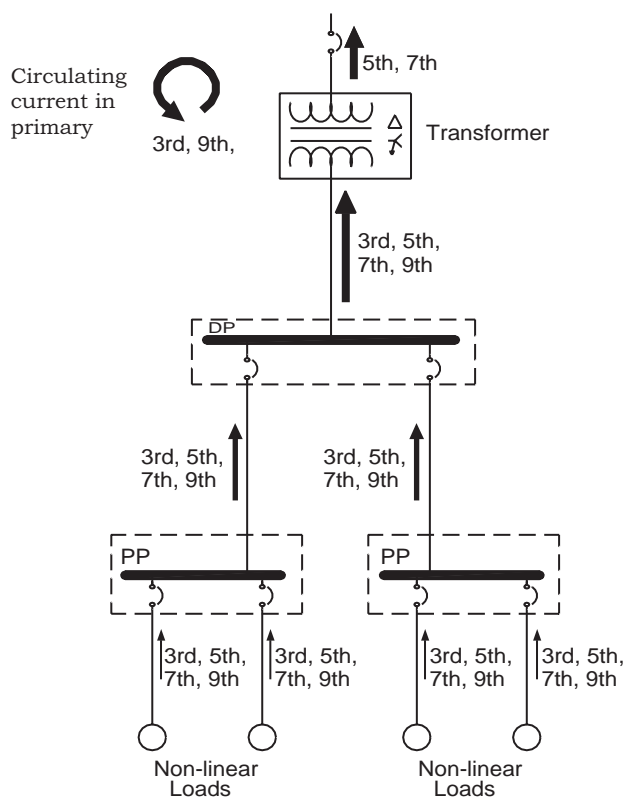

Figure 6: Flow of harmonic currents in typical 4-wire distribution system without treatment

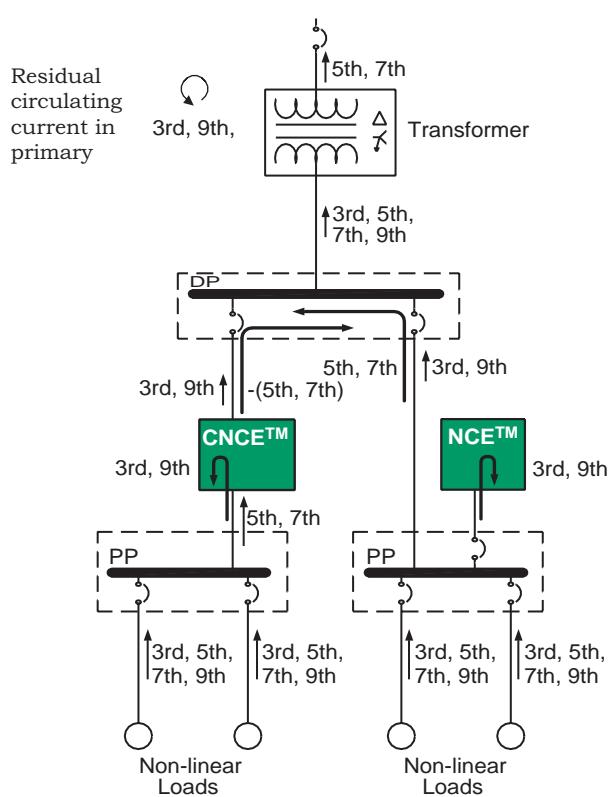

Figure 7: Cancellation of harmonic currents using NCE™ and CNCE™

Note: Thickness of arrows indicates the relative amount of harmonic current

Flow of Harmonic Currents in a Typical Application

Figure 6 shows how the most common harmonics (3rd, 5th, 7th and 9th) generated by today's non-linear loads will flow in a typical 3-phase, 4-wire electrical distribution system. Just as the load current is larger, the harmonic currents are larger close to the supply transformer. At the transformer, the 3rd and 9th harmonics will circulate in its primary windings while the 5th and 7th harmonics will continue to flow upstream passing through the transformer.

Note: In harmonic analysis it is convenient to think of the non-linear loads as current sources that send harmonic currents towards the utility.

The MIRUS NCE™ is designed to treat the triplen harmonics (3rd, 9th, 15th, etc.) and other zero sequence currents (such as the 60 Hz unbalance) by diverting the flow of these currents from the neutral directly back to the loads where they were generated. When installed near the harmonic generating loads (such as at the power panel) the NCE™ will attract these currents by offering a lower impedance path than the alternate path to

the upstream transformer. This will off-load the neutral conductor and transformer allowing them to run much cooler and eliminating the need to double the neutral and replace the transformer.

When treatment of 5th and 7th harmonics is also required, the MIRUS CNCE™ should be used as shown in Figures 5 and 7. The 5th and 7th harmonic currents returning through the CNCE™ will cancel against those returning directly from other non-linear loads. And as with the NCE™, the triplen harmonic currents are diverted away from the neutral conductor when they reach the CNCE™. The net result is a much more linear current at the supply transformer with less harmonic components and lower k-factor rating. This in turn will reduce the overheating, neutral-to-ground voltage and voltage distortion that these harmonic currents would normally produce. Also, since harmonic currents carry no real power, removing them will significantly improve upstream power factor, freeing up valuable system capacity and reducing system losses.

When to choose the Field Adjustable Impedance (FAI) option:

A patented feature of the MIRUS design, FAI provides some flexibility in the application of NCE™'s and CNCE™'s. As a parallel connected device, the NCE™ may attract some neutral current from its upstream side in addition to the larger portion of neutral current drawn from its downstream side. In some instances this may be a preferred characteristic because the upstream transformer will carry even less triplen harmonic current. However, if it is anticipated that the presence of upstream harmonics might cause overloading of the NCE™, then the FAI option should be specified. This will allow the zero phase sequence impedance of the NCE™ to be adjusted upward (by a simple tap change) thereby lowering the amount of neutral current drawn by the NCE™ and avoiding the possible overload.

On the CNCE™, the FAI option provides the ability to attract neutral current from its line side as well as its load side. As a series connected device, the standard CNCE™ will attract very little neutral current from its line side. For applications where removal of line side neutral current is desirable, invoking the FAI option will lower the devices input zero sequence impedance and increase the neutral current consumption from its line side. This feature is particularly valuable when the CNCE™ is used to treat harmonics on a 208V riser or busduct run. By removing neutral current from its line side, the CNCE-FAI™ will eliminate the need for NCE™'s at the panels not supplied by a CNCE™. The FAI option was implemented in the CNCE™ application in Figure 5.



5-7, 5-13 and 11-13 Eliminators™

5-7, 5-13 and 11-13 Eliminators™ can be used to produce quasi 12, 18 and 24-pulse schemes when servicing 3-phase, 3-wire rectifier loads such as variable frequency drives (VFD), UPS units and mainframe computer equipment. The 5-7 Eliminator™ is a phase shifting auto-transformer which, when used to supply a 6-pulse rectifier load, will phase shift the 5th and 7th harmonics returning from this load so that they cancel with 5th and 7th harmonics returning from other unshifted 6-pulse rectifier loads. This results in effectively a 12-pulse operation upstream at the common distribution point.

When servicing 12-pulse rectifier loads, the 11-13 Eliminator™ can be used to produce a 24-pulse scheme by phase shifting one load against another.

When three rectifiers (or multiples thereof) require treatment, utilizing a 5-13 Eliminator™ on each of two loads will produce a quasi 18-pulse scheme (ie. cancellation of 5th, 7th, 11th and 13th harmonics).

For the most optimum harmonic cancellation, a combination of 5-7 Eliminators™ and 11-13 Eliminators™ can be used to service multiples of four 6-pulse rectifier loads (see last page) to produce a quasi 24-pulse operation. In most cases, this type of configuration will meet the very stringent harmonic current and voltage limits as defined by IEEE Std 519-1992.

For an alternate method of VFD harmonic treatment, see the Mirus Lineator™ Universal Harmonic Filter.



Eliminator™ Series Products

Eliminator™ Products	Application Description
<p>Neutral Current Eliminator™ (NCE™)</p> <p>Harmonics Treated: 3rd, 9th & 15th</p>	<ul style="list-style-type: none"> • Parallel connected on 3-ph, 4-wire systems to divert the flow of triplen harmonic currents (3rd, 9th & 15th) away from the neutral conductor and upstream transformer • Used in systems with non-linear, line-to-neutral (120V) loads • Best results are achieved when installed at a downstream power panel (fed from a 3 pole branch CB) near the harmonic generating loads • The phase current returned by the NCE™ will be equal to 1/3 the neutral current drawn and must be protected accordingly. E.g., a 100A 3 pole circuit breaker is used to protect a 300A NCE™ • On installations where neutral current could be drawn from upstream side of the NCE™ (ie. multiple subpanels) or where the downstream load is expected to grow, the Field Adjustable Impedance (FAI) option should be selected
<p>Combined Neutral Current Eliminator™ (CNCE™)</p> <p>Harmonics Treated: 3rd, 5th, 7th, 9th, 15th, 17th, & 19th</p>	<ul style="list-style-type: none"> • Series connected on 3-ph, 4-wire systems to cancel 5th and 7th harmonics through phase shifting while also diverting the flow of triplen harmonic currents away from the neutral and upstream transformer • CNCE™ normally feeds about 1/2 the power panels on a distribution system, busduct or riser which feeds non-linear, line-to-neutral (120V) loads with high levels of 3rd, 5th & 7th harmonics • Standard transformer design practices should be used for sizing upstream protection. (ie. 225A circuit breaker for 75 kVA, 208V CNCE™) • Field Adjustable Impedance (FAI) option allows for attraction of triplen harmonics from upstream side of the CNCE™ when desired
<p>Combined use of NCE™ and CNCE™</p> <p>Harmonics Treated: 3rd, 5th, 7th, 9th, 15th, 17th, & 19th</p>	<ul style="list-style-type: none"> • A combination of NCE™'s and CNCE™'s will produce the best harmonic mitigating performance • CNCE™'s feed about 1/2 of the load, diverting the returning neutral current and phase shifting 5th and 7th harmonic currents so that they cancel with unshifted 5th & 7th harmonic currents from other non-linear loads • NCE™'s are used to treat the triplen harmonics at all other power panels
<p>5-7, 5-13 and 11-13 Eliminators™</p> <p>Harmonics Treated: 5th, 7th, 11th, 13th, 17th, & 19th</p>	<ul style="list-style-type: none"> • Used to treat the characteristic harmonics of 3-ph, 6-pulse rectifier loads, such as variable frequency drives (VFD's), in a 3-wire system • A quasi 12-pulse scheme (ie. cancellation of 5th, 7th, 17th & 19th harmonics) will result when a VFD fed through a 5-7 Eliminator™ is paired with a VFD that is fed directly • The 5-13 Eliminator™ can be used to create a quasi 18-pulse scheme when three 6-pulse VFD's (or multiples thereof) require harmonic treatment. By using 5-13 Eliminators™ to feed two of the three VFD's, 5th, 7th, 11th and 13th harmonics are canceled on the common feeder. • Combining one 5-7 Eliminator™ with two 11-13 Eliminators™ creates a quasi 24-pulse scheme that cancels all characteristic harmonics below the 23rd.

Note: Single -phase fault level will increase with the use of low zero sequence impedance products such as the NCE™ and CNCE™. (See MIRUS 'Design Note # 1' for more information on fault level calculations)

Application Example	Typical Performance				
	Voltage Distortion	Current Distortion	Neutral Current	Neutral-GND Voltage	Power Factor
<p>NCE™</p>	40 - 60% reduction	40 - 60% reduction	60 - 80% reduction	Less than 2 volts	Above 90%
<p>CNCE™</p>	65 - 80% reduction	65 - 90% reduction	65 - 90% reduction	Less than 2 volts	Above 90%
<p>NCE™ & CNCE™</p>	70 - 90% reduction	70 - 90% reduction	75 - 95% reduction	Less than 2 volts	Above 95%
<p>5-7 & 11-13 Eliminator™ (3-wire system)</p>	40 - 60% reduction	40 - 60% reduction	Not Applicable (3-wire system)	Not Applicable (3-wire system)	Above 95%

This guide illustrates the general application of MIRUS products only. To ensure proper implementation for a specific installation, please consult factory.



ELIM-TG01-A1
Effective: November 2003