

Product Information Sheet

DRIVE TAMER™

- Replaces conventional Drive isolation transformer
- Configured for 6-pulse or 12-pulse drives
- Cancellation of 5th & 7th harmonics (6-pulse) or 11th & 13th harmonics (12-pulse) on primary side with other sources

General

The MIRUS DRIVE TAMER™ is designed to replace a drive isolation transformer that feeds a variable speed or variable frequency drive. It is available in two configurations - one for 6-pulse drives and the other for 12-pulse drives.

Drives produce significant amounts of harmonic currents. Depending on the pulse number of the drive, different but typical harmonics appear. A 6-pulse drive generates 5th & 7th harmonics, and a 12-pulse drive generates 11th & 13th harmonics.

The high level of harmonics produced by a drive places considerable stress on the drive isolation transformer resulting in significant extra heating of the transformer itself and increased voltage distortion both at the drive and throughout the distribution system feeding other equipment.

Excessive voltage distortion due to the current harmonics can cause significant operational problems for the drives themselves as well as for other sensitive loads such as PCs and other electronic equipment. The most visible consequences of excessive voltage distortion are erratic malfunctions and premature component failure.

Product Description

The DRIVE TAMER™ is a single output transformer that replaces conventional as well as K-factor rated drive isolation transformers. While K-factor transformers are able to **withstand** harmonics, DRIVE TAMER™ transformers actually **cancel** harmonics.

The DRIVE TAMER™ uses patent-pending electromagnetics to cancel the drive harmonics (5th & 7th, or 11th & 13th) on its load side with other sources of the same harmonic currents on its primary side. It is a passive device with no capacitors or electronics, which have a long history of problems. Since there are generally several harmonic current sources, the DRIVE TAMER™ approach is very effective. Since the

problem harmonic currents are canceled, voltage distortion drops significantly. Benefits include:

- Healthy electrical environment
- Increased system capacity and reliability
- Longer life span of equipment (power system equipment as well as the drive itself)
- Less downtime due to failures and malfunctions of equipment
- Improved Power Quality throughout system

Example of electrical distribution with drive isolation transformers

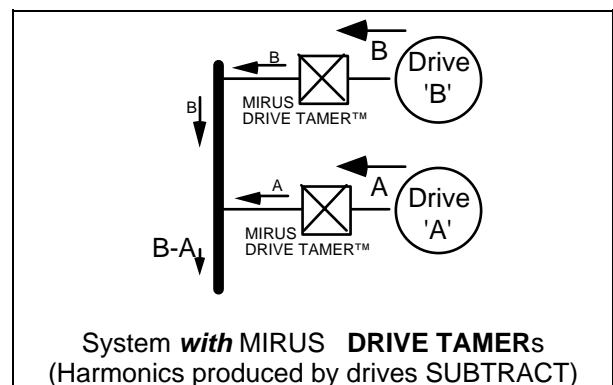
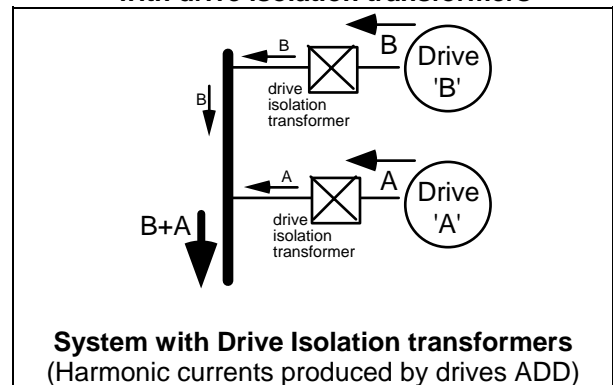

The MIRUS DRIVE TAMER™ approach has none of the risks that installing capacitors or tuned filters are known to have in low-voltage systems, including the risk of resonance and overloading of

Product Information Sheet: MIRUS DRIVE TAMER™

the capacitor/filter due to changing loads. Because our devices are based on electromagnetics (no complicated electronics), their reliability is significantly higher.

Typical Performance

Parameter	Result
5th & 7th or 11th & 13th Harmonic current	up to 100% reduction through primary cancellation
voltage distortion	will meet IEEE-519

Reliability

The DRIVE TAMER™ has no moving parts, and its Mean Time Between Failures (MTBF) meets or exceeds top-of-the-line transformers.

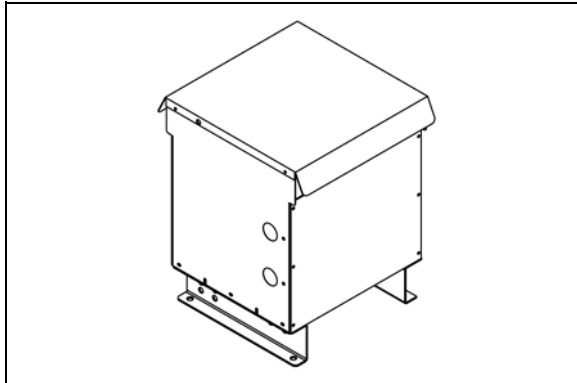

Maintenance Requirements

No maintenance is required, and the unit operates unattended.

Isolation / Shielding

Where high frequency isolation is required, the shielding option should be selected.

Sizing & Installation

Appropriate sizing of the DRIVE TAMER™ is made by matching the unit size to the kVA requirements of the drive. Installation is as per standard electrical code practices relating to transformers.

Units are available in standard kVA and voltages ranges for 3-Phase 60Hz Application (Other capacities/voltages are available.)

Unit Selection Part #
DT-dd-hhh-yyy-kVA-X

Where: dd is angular displacement
hhh is primary voltage
yyy is secondary voltage
kVA is unit rated kVA
X is electrostatic shield

Specifications are subject to change due to ongoing product development.

Related Products:

NEUTRAL CURRENT ELIMINATOR™ (NCE™)
COMBINED NEUTRAL CURRENT ELIMINATOR™ (CNCE™)
HARMONY™ Series Transformers
5-7 ELIMINATOR™, 11-13 ELIMINATOR™

DISTRIBUTED BY:

MIRUS PRODUCTS ARE CSA APPROVED & UL LISTED

MIRUS International Inc.