

Single Row Terminal Blocks

Kulka® 1690 GP Series

300 Volts AC/DC

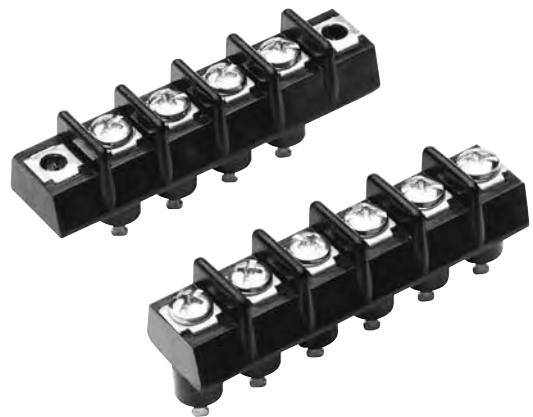

Specifications:

- Base, Phenolic, 150°C
- Screws, #6-32 Binder Head, Phil-Slot, Brass
- Terminals, Plated Brass
- 7/16" Centers
- Wire Range #14 Max. - 20 Amps
- UL Recognized File No. XCFR2.E47811
- CSA Certified File No. LR19766
- **CE**
- RoHS Compliant

TERMINAL BLOCK SERIES

# of poles	1691 GP 1692 GP 1693 GP		1694 GP 1695 GP 1696 GP		1697 GP 1698 GP 1699 GP	
	A	B	A	B	A	B
1	0.34	--	1.22	0.88	0.53	--
2	0.78	0.44	1.66	1.31	0.97	0.44
3	1.22	0.88	2.09	1.75	1.41	0.88
4	1.66	1.31	2.53	2.19	1.84	1.31
5	2.09	1.75	2.97	2.63	2.28	1.75
6	2.53	2.19	3.41	3.06	2.72	2.19
7	2.97	2.63	3.84	3.50	3.16	2.63
8	3.41	3.06	4.28	3.94	3.59	3.06
9	3.84	3.50	4.72	4.38	4.03	3.50
10	4.28	3.94	5.16	4.81	4.47	3.94
11	4.72	4.38	5.59	5.25	4.91	4.38
12	5.16	4.81	6.03	5.69	5.34	4.81
13	5.59	5.25	6.47	6.13	5.78	5.25
14	6.03	5.69	6.91	6.56	6.22	5.69
15	6.47	6.13	7.34	7.00	6.66	6.13
16	6.91	6.56	7.78	7.44	7.09	6.56
17	7.34	7.00	8.22	7.88	7.53	7.00
18	7.78	7.44	8.66	8.31	7.97	7.44
19	8.22	7.88	9.09	8.75	8.41	7.88
20	8.66	8.31	9.53	9.19	8.84	8.31
21	9.09	8.75	9.97	9.63	9.28	8.75
22	9.53	9.19	10.41	10.06	9.72	9.19
23	9.97	9.63	10.84	10.50	10.16	9.63
24	10.41	10.06	--	--	--	--
25	10.84	10.50	--	--	--	--

mm = dim X 25.4

Include "PSB" after part # when ordering (169X GP XX PSB)

See page 96 for 1690 Series Terminal block dimensions.

Hardware Options:

(Hardware options may affect ratings - consult Customer Service)

CATALOG # MSP KULKA	PRODUCT DESCRIPTION	PAGE REFERENCE
KT46	Full Quick Connect (0° Flat)	See page 100
KT47	Full Quick Connect (45° Bend)	See page 100
KT48	Full Quick Connect (90° Bend)	See page 100
KT52	Half Quick Connect (0° Flat)	See page 100
KT53	Half Quick Connect (45° Bend)	See page 100
KT54	Half Quick Connect (90° Bend)	See page 100
3/4 ST	Half Solder	See page 102
J 601	Line to Line Jumper	See page 103
601 RJ(S)	Multiple Position Jumper	See page 103

Quick Connects: .032" x .250"

See pages 100-111 for terminal block accessories

Single Row Terminal Blocks

Kulka® 1690 GP Series (cont.)

TERMINAL BLOCK SERIES 1691 GP / 1692 GP / 1693 GP

- 1691 GP Series** Solder terminal
K = .52 [13.10]; W = .06 [1.59]
- 1692 GP Series** Kliptite terminal
- 1693 GP Series** Solder terminal
K = .58 [14.68]; W = .13 [3.18]

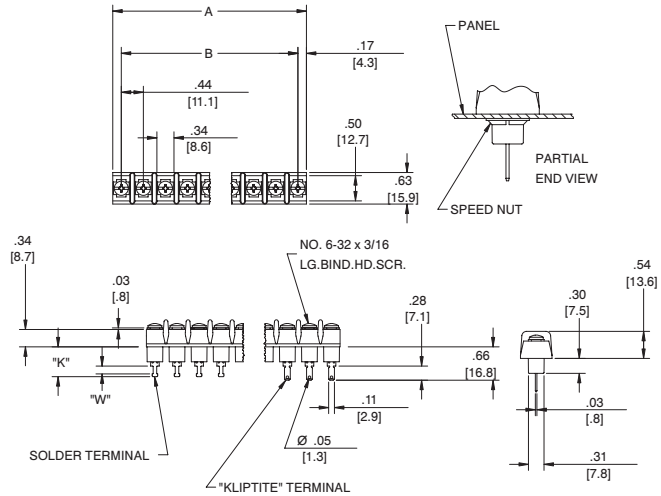

TERMINAL BLOCK SERIES 1694 GP / 1695 GP / 1696 GP

- 1694 GP Series** Solder terminal
K = .52 [13.10]; W = .06 [1.59]
- 1695 GP Series** Kliptite terminal
- 1696 GP Series** Solder terminal
K = .58 [14.68]; W = .13 [3.18]

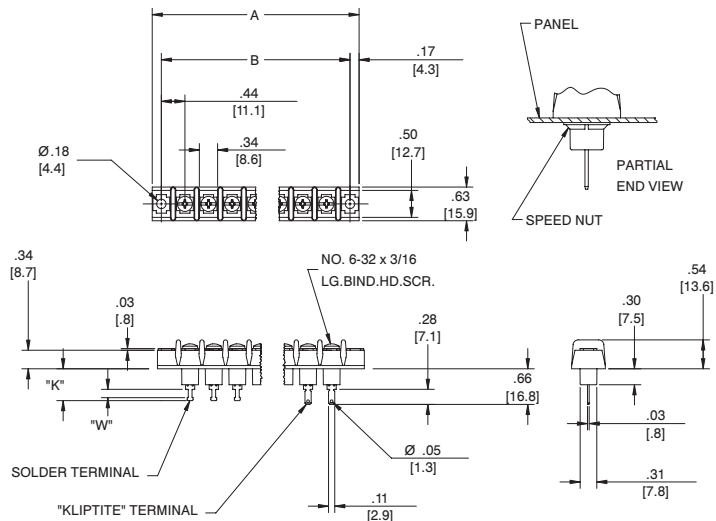

TERMINAL BLOCK SERIES 1697 GP / 1698 GP / 1699 GP

- 1697 GP Series** Solder terminal
K = .52 [13.10]; W = .06 [1.59]
- 1698 GP Series** Kliptite terminal
- 1699 GP Series** Solder terminal
K = .58 [14.68]; W = .13 [3.18]

