

Class H & K Fuse Panels

30 and 60 Amp - 250 Volt

Specifications:

- Base, General Purpose Phenolic, 150°C
- Patented Cool-Clip® Design
- Clip, Copper Alloy, Tin Plated
- Reinforcing Member Available
- Bus Bars are Available with 2/0 - #14 AWG or 250 kcmil - #6 Wire Ranges
- Consult Customer Service for Special Requirements
- UL Recognized File No. IZLT2.E35113
- CSA Certified File No. LR21455
- **CE**
- RoHS Compliant



RH40Q2L



RH42C2F

Ordering Code:

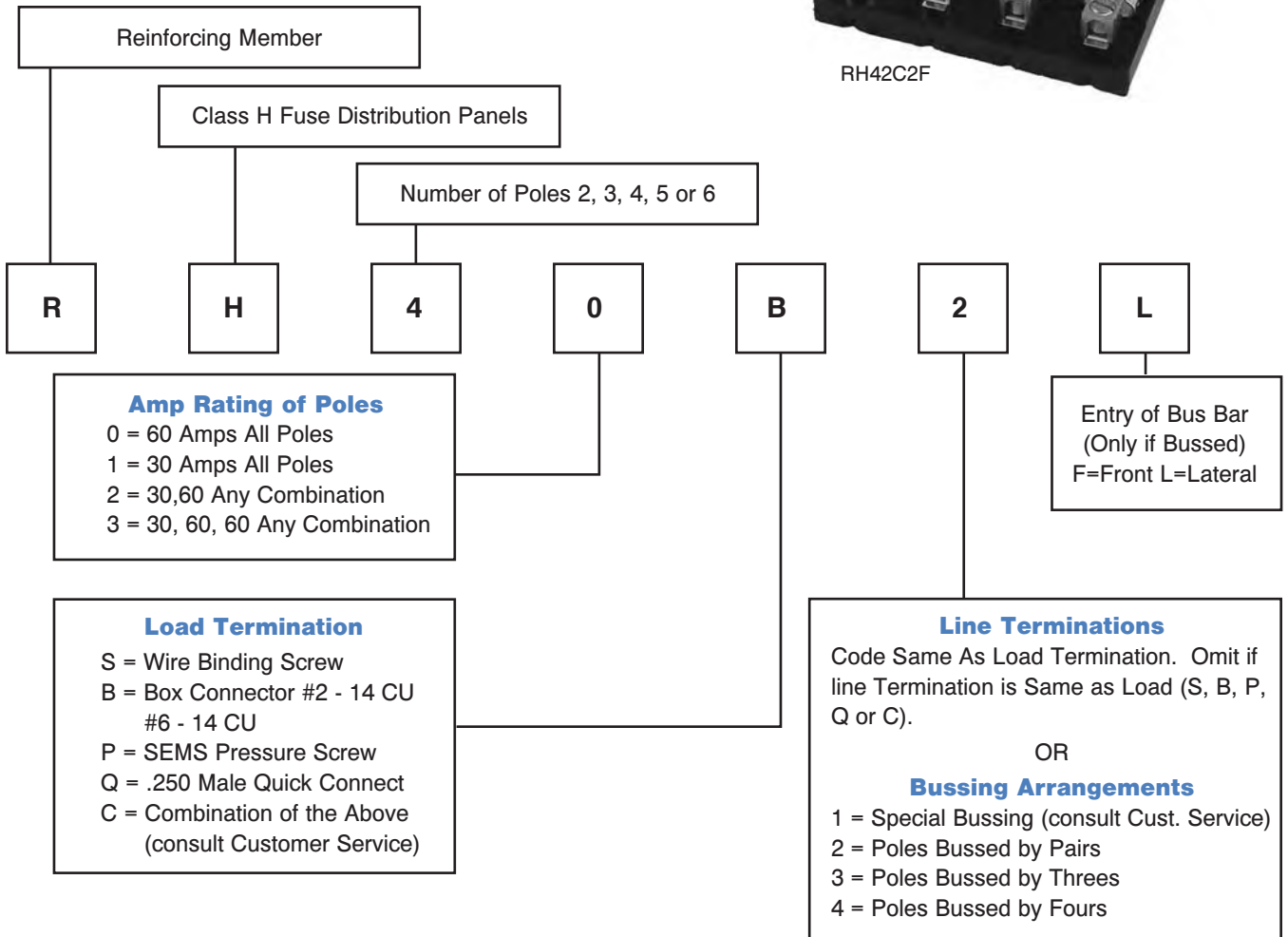

Class H & K Fuse Panels (cont.)

30 and 60 Amp - 250 Volt

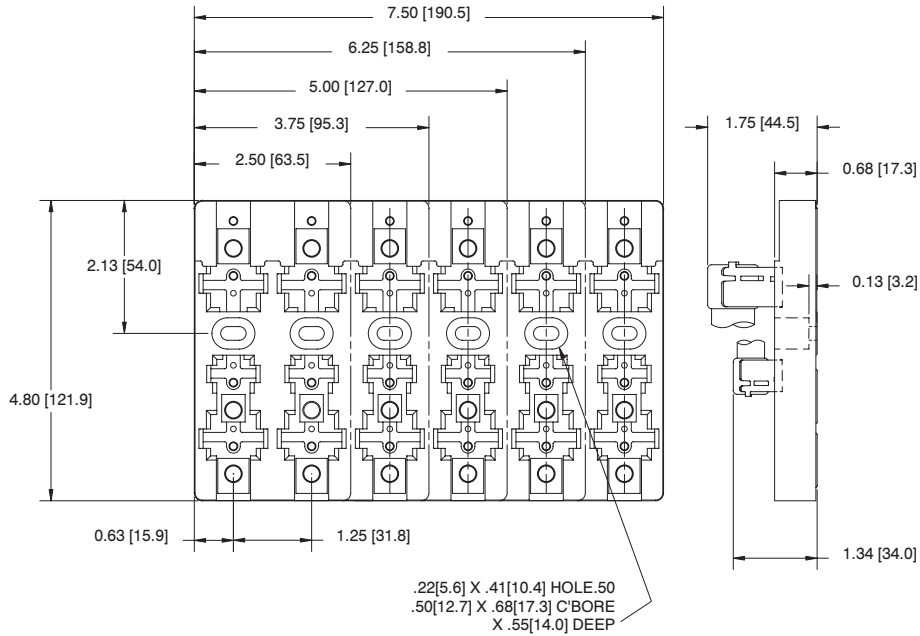

Poles No.	Dimensions (in) L	(mm)	Poles No.	Dimensions (in) L	(mm)	Dimensions (in) (mm)
2	2.50	63.5	5	6.25	158.8	(in) (mm)
3	3.75	95.25	6	7.50	190.5	(mm)
4	5.00	127.0				

Fuse Distribution Panel Options

Circle/indicate one item per pole and number of poles. The items to be indicated are within the rectangles.

Bussing is only available on line side. If bussing, indicate lug size 2/0 or 250 kcmil (F = Front entry, L = Lateral entry)

Consult Customer Service for other modifications.

