



SRK 96



Protective retro-reflective photoelectric sensor

! Safety note:

- The protective retro-reflective photoelectric sensor SRK 96... only works in connection with the special reflectors PTKS 50x50, PTKS 20x40 or PTKS 100x100
- The reflectors have to be installed in the correct position.
- The protective retro-reflective photoelectric sensor is a contactless active protective device only in connection with a safety-relevant control system, in which the cyclical testing of transmitter and receiver is carried out according to EN 61496-1, category 2 (testing).
- The power supply unit used to operate the photoelectric sensor has to be able to compensate for changes and interruptions of the supply voltage acc. to EN 61496-1.
- The protective retro-reflective photoelectric sensor SRK 96 operates with a class 2 red light laser in acc. with EN 60825-1 and also meets 21 CFR 1040.10 with the exception of deviations in accordance with laser notice no. 50 from July 2001.



Features

- Protective retro-reflective photoelectric sensor category 2 (testing) with high performance reserve in visible red light and infrared light
- Robust metal housing with glass cover, protection class IP 67 for industrial application
- Activation input for function testing and interlinking
- 2 LED for status display when commissioning and in operation
- Connection via M12 connector or terminal compartment

Electrical Connection

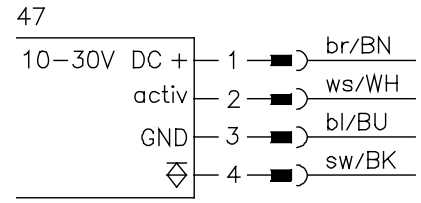
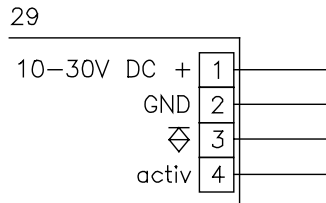

Dimensional Drawing

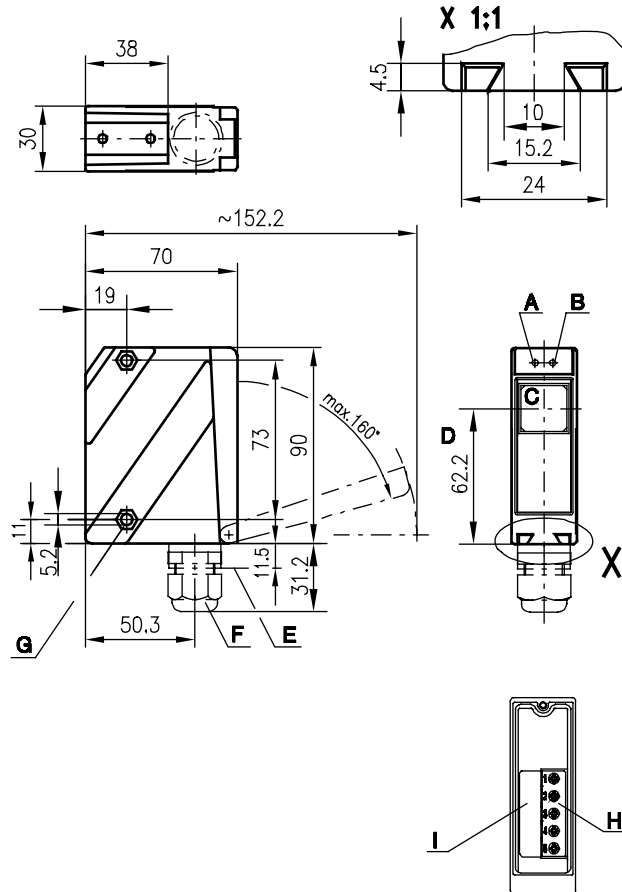

- A Indicator diode green
- B Indicator diode yellow
- C Transmitter/receiver
- D Optical axis
- E Device plug M12
- F Screwed cable gland M16x1.5 for Ø5 ... 10mm
- G Countersinking for SK-nut M5, 4.2 mm deep
- H Connection terminals
- I Cable entry



Technical Data

Optical data	
Typ. operating range limit ¹⁾	0.5 ... 7m
Operating range ²⁾	0.5 ... 6m
with reflector	PTKS 50x50, PTKS 20x40, PTKS 100x100
Light source	red light laser diode
Wavelength	670nm
Laser class	2 acc. to EN 60825-1: 1993 + A1:2002 + A2:2001
Laser warning notice	see remarks
Timing	
Sensor switching frequency	100Hz
Sensor response time	6ms
Delay before start-up	≤ 200ms
Electrical data	
Operating voltage U _B	10 ... 30VDC (incl. residual ripple)
Residual ripple	≤ 15% of U _B
Bias current	≤ 40mA
Switching output	PNP-transistor
Function characteristics	light switching
Signal voltage high/low	≥(U _B -2V) / ≤ 2V
Output current	max. 100mA
Indicators	
LED green	ready
LED yellow	light path free
LED yellow flashing	light path free, no performance reserve
Mechanical data	
Housing	diecast zinc, yellow
Optics cover	glass
Weight	380g
Connection type	terminals or M12 connector
Environmental data	
Ambient temp. (operating/storage)	-10°C ... +50°C/-30°C ... +60°C
Protective circuit ³⁾	1, 2, 3, 4
VDE safety class ⁴⁾	II, all-insulated
Protection class	IP 67
Standards applied	EN 61496/1
Options	
Activation input active	
Transmitter active/not active	≥ 8V/ ≤ 2V
Input resistance	10kΩ ± 10%
Testing time	12ms + response time test monitoring unit

1) Typ. operating range limit: max. attainable range without performance reserve

2) Operating range: recommended range with performance reserve

3) 1 = transient protection, 2= polarity reversal protection, 3= short circuit protection for all outputs, 4= interference blanking

4) Rating voltage 250 VAC

Dimensional Drawing - reflector

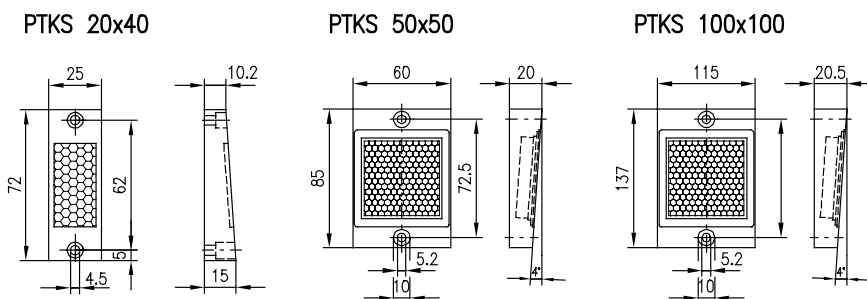

Order guide

	Designation	Part No.
with M12 connector	SRK 96M/P-1210-T2-47	500 60919
with terminal connection	SRK 96M/P-1210-T2-29	500 60918

Accessories

(available separately)

- Mounting systems (BT 96, UMS 96, BT 450.1-96)
- M12 connectors (KD ...)
- Reflector PTKS 50x50, 20x40, 100x100
- Test-monitoring units:
 - TNT 32 (Part No. 500 20476)
 - TNT 33 (Part No. 500 28158)
 - TNT 34 (Part No. 500 81023)
 - TNT 35 (Part No. 500 33058)
 - TMC 66 (Part No. 500 82121)
- Connection cable for series connection of several sensors (BK7 KB-4-SRK 96-600-4)

Tables

Reflectors	Operating range
PKTS 100x100	0.5 ... 6m
PKTS 50x50	0.5 ... 6m
PKTS 20x40	0.5 ... 4m