

SLS 78M/P-1730-T2-4

Through-beam Safety Light Barriers (AOPD type 2)

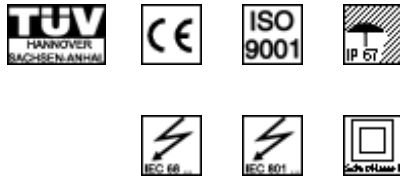

SLS 78M/P-1730-T2-4

In conjunction with a test monitoring unit, such as for instance the TNT 35 or MSI-s/R, this opto-sensor with test input constitutes an active optoelectronic protective device of type 2.

Advantages

- Through-beam safety light barriers with high output in infra red light
- Sturdy metal housing with glass lens in enclosure rating IP 65 for industrial use
- Activating input for testing and connecting of the sensor
- pnp transistor output for PLC operations
- Connection via M12 circular plug-in connection
- Intergrated lens heating system

SLS 78M/P-1730-T2-4
Dimensional Drawings

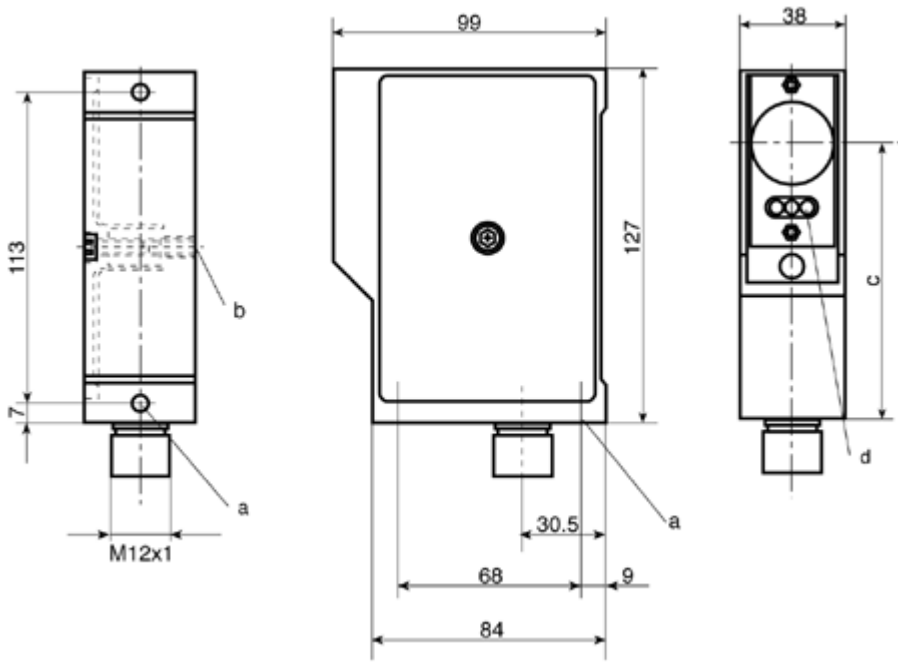

a)	Machine mounting M6x9
b)	Device mounting M6x12
c)	Optical axis 100
d)	Display mode

Display LEDs

Transmitter: LED yellow, if transmitter active

Receiver:

red	green	
On	Off	Sensing field not free
Off	Flashes	Sensing field free Function reserve - no
Off	On	Sensing field free Function reserve - yes

SLS 78M/P-1730-T2-4

Electrical Connection

Application drawing SLS 78/M

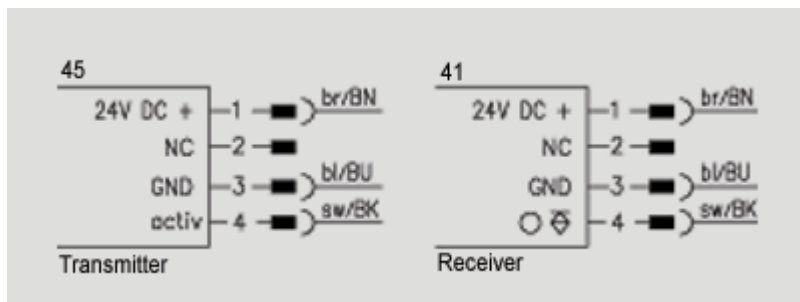

SLS 78M/P-1730-T2-4

Technical Data

Safety Light Barrier	SLS 78M/P-1730-T2-4
Safety category	Type 2 according to EN 61496-1,-2 in combination with a test monitoring unit.
Operating range ¹⁾	0 - 120 m
Limit range ²⁾	0 - 150 m
Light source	LED (alternating light)
Wave length	880 nm
Enclosure rating	IP 65
Operation voltage U _B	24 V DC 20 %
Residual ripple	≤15 % von U _B
No-load current	Transmitter: 60 mA Receiver: & 35 mA
Switching output	pnp transistor output
Releasing time	max. 200 mA
Function	bright switching
Signal voltage high/low	≥(U _B - 2 V) / ≤2 V
Output current	max. 200 mA
Switching frequency	300 Hz
Pickup time	1,7 ms
Readiness delay	≤5 ms
Initial impulse	min. 1,7 ms
Transmitter LED yellow	Transmitter ON
Receiver LED green LED green, flashing LED red	Light path free Light path free, no functional reserve Light path interrupted
Housing	Aluminium die casting
Optical parts	Glass, Effective apperture angel ±4°
Weight	463 g
Connection	M12 circular plug connection, 4-pin plug
Ambient temperature (operation/storage)	-25 °C ... +60 °C / -30 °C ... +70 °C
VDE-Protection class	III
Protective cabling ³⁾	1, 2, 3
Shock proof	Semi sine, 30 gn, 11 ms (IEC 947-5-2)
Vibration proof	10 - 55 Hz, max. 7,5 gn (IEC 947-5-2)
Electromagnetic tolerance	Degree of severity 3 (IEC 801.2...4)
Transmitter activ/not aktiv	≥8 V / ≤2 V or not wired
Activation/locking delay	≤400 µs
Input resistance	4,7 kΩ ± 10 %

¹⁾ Operating range: recommended Range with functional reserve

²⁾ Limit range: max. possible range without function reserve

³⁾ 1 = transient protection, 2 = pole reversal protection, 3 = Short circuit protection

Activating input enables a logical connection of several light barriers.

Example:

Connection of several light barriers (max. 6 per channel) in series-connection to a monitoring unit.

Function:

The active input on the first light barrier transmitter of a series connection is connected to the initial input of the monitoring unit. After monitoring is released, transmitter is activated. The matching first receiver switches to signal "high". With this signal the next transmitter is activated and the matching receiver switches also to signal "high". The last receiver switching output of the group series connection is led back to the monitoring unit. The operating voltage is connected separately to all sensors.

Note:

The through-beam safety light barrier is an electro-sensitive protective device only in connection with a safety-relevant control system where the cyclical testing of transmitter and receiver is carried out according to EN-/IEC 61496-1, 2, category 2 (testing). The power supply to the light barrier must intercept changes and interruptions in the supply voltage in accordance with EN 61496-1. Minimum darkening object Ø 30 mm.