

ODSL 9

Optical laser distance sensors

EN 01-2009/07 501 11883



Dimensioned drawing

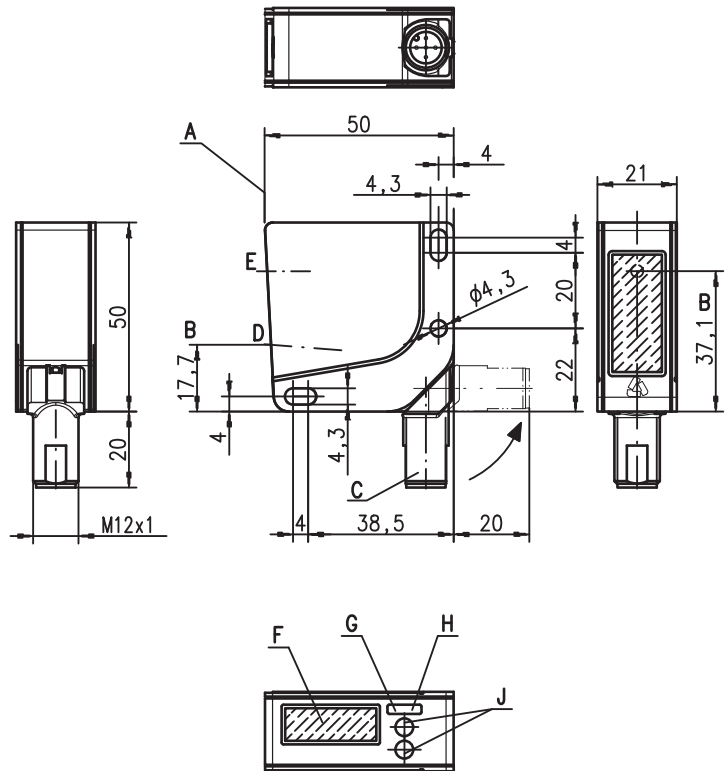

- A** Reference edge for the measurement
- B** Optical axis
- C** Device plug M12
- D** Receiver
- E** Transmitter
- F** LCD display
- G** Indicator diode yellow
- H** Indicator diode green
- J** Control buttons

Electrical connection

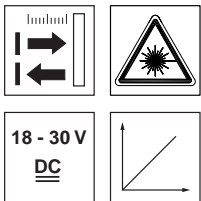
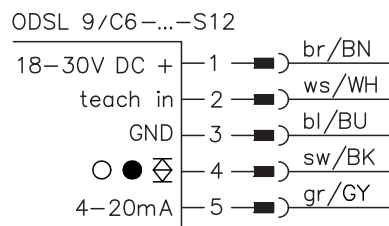
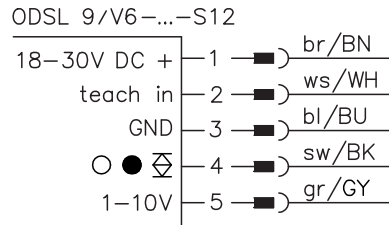

50 ... 100mm

- Reflection-independent distance information
- Highly insensitive to extraneous light
- Analogue current and voltage output
- Measurement range and mode adjustable
- Teachable switching output
- M12 turning connector

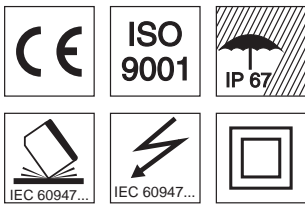

Accessories:

(available separately)

- Mounting systems
- Configuration software
- Cable with M12 connector (K-D ...)

We reserve the right to make changes • DS_ODSL9_C6_V6-100-S12_EN.fm

Specifications

Optical data

Measurement range ¹⁾	50 ... 100mm
Resolution	0.01 mm
Light source	laser
Wavelength	655nm
Light spot	divergent, 1x1mm ² at 100mm
Laser warning notice	see remarks

Error limits (relative to measurement distance)

Absolute measurement accuracy ¹⁾	± 0.5%
Repeatability ²⁾	± 0.25%
B/W detection thresh. (6 ... 90% rem.)	≤ 0.5%
Temperature compensation	yes ³⁾

Timing

Measurement time	2ms
Response time ¹⁾	≤ 6ms
Delay before start-up	≤ 300ms

Electrical data

Operating voltage U_B	18 ... 30VDC (incl. residual ripple)
Residual ripple	≤ 15% of U_B
Open-circuit current	≤ 180mA
Switching output	push-pull switching output ⁴⁾ , PNP light switching, NPN dark switching
Signal voltage high/low	≥ ($U_B - 2V$) / ≤ 2V
Analogue output	voltage 1 ... 10V / 0 ... 10V / 1 ... 5V / 0 ... 5V, $R_L \geq 2k\Omega$ current 4 ... 20mA, $R_L \leq 500\Omega$

Indicators

Green LED	continuous light	teach-in on GND	teach-in on +U_B
	flashing	ready	
	off	fault	teaching procedure
Yellow LED	continuous light	no voltage	
	flashing	object inside teach-in measurement distance	teaching procedure
	off	object outside teach-in measurement distance	

Mechanical data

Housing	plastic
Optics cover	glass
Weight	approx. 50g
Connection type	M12 connector, 5-pin

Environmental data

Ambient temp. (operation/storage)	-20°C ... +50°C / -30°C ... +70°C
Protective circuit ⁵⁾	1, 2, 3
VDE safety class ⁶⁾	II, all-insulated
Protection class	IP 67
Laser class	2 (acc. to EN 60825-1)
Standards applied	IEC 60947-5-2

- 1) Luminosity coefficient 6% ... 90%, complete measurement range, "Standard" operating mode, at 20°C, medium range of U_B , measurement object $\geq 50 \times 50 \text{mm}^2$
- 2) Same object, identical environmental conditions, measurement object $\geq 50 \times 50 \text{mm}^2$
- 3) Typ. $\pm 0.02\% / K$
- 4) The push-pull switching outputs must not be connected in parallel
- 5) 1=transient protection, 2=polarity reversal protection, 3=short circuit protection for all outputs
- 6) Rating voltage 50VAC

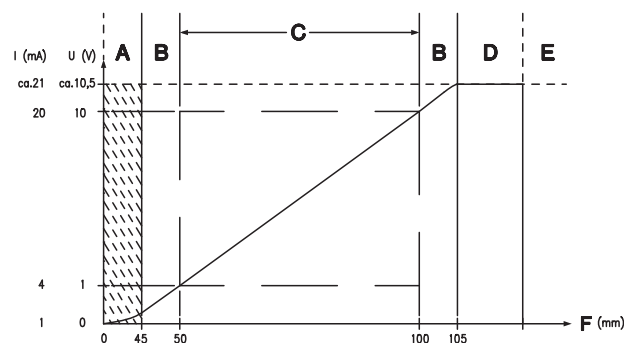

- A Area not defined
- B Linearity not defined
- C Measurement range
- D Object present
- E No object detected
- F Measurement distance

Tables

Diagrams

Remarks

- Measurement time depends on the reflectivity of the measurement object and on the measurement mode.
- **Approved purpose:** The ODSL 9 laser distance sensors are optical electronic sensors for the optical, contactless measurement of distance to objects.

LASER LIGHT	
DO NOT STARE INTO BEAM	
Maximum Output:	1.2mW
Pulse duration:	22ms
Wavelength:	655nm
CLASS 2 LASER PRODUCT	
EN60825-1:2003-10	

Order guide

	Designation	
With M12 connector		
Current output	ODSL 9/C6-100-S12	501 11167
Voltage output	ODSL 9/V6-100-S12	501 11168

ODSL 9

Optical laser distance sensors

EN 01-2009/07 501 11882



Dimensioned drawing

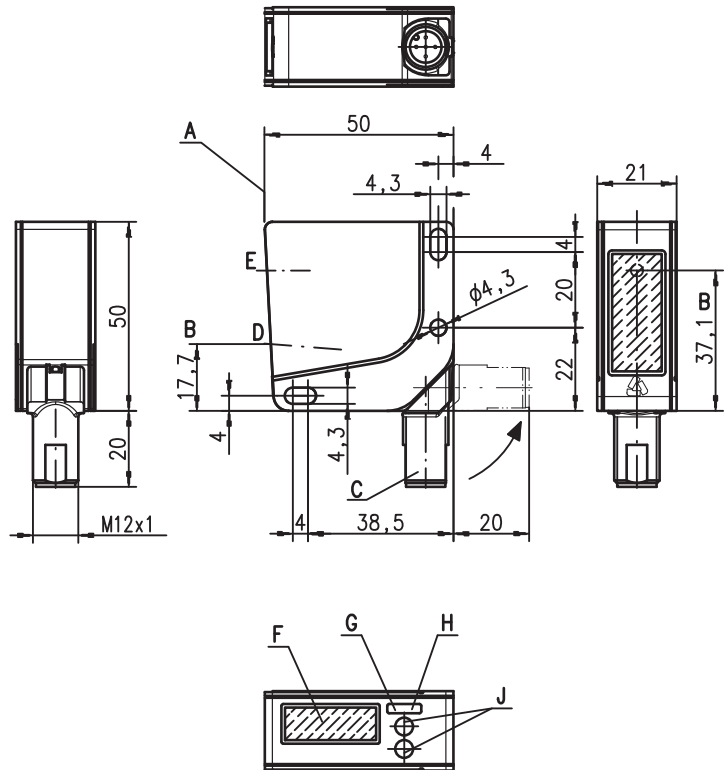

- A** Reference edge for the measurement
- B** Optical axis
- C** Device plug M12
- D** Receiver
- E** Transmitter
- F** LCD display
- G** Indicator diode yellow
- H** Indicator diode green
- J** Control buttons

Electrical connection

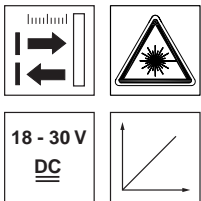
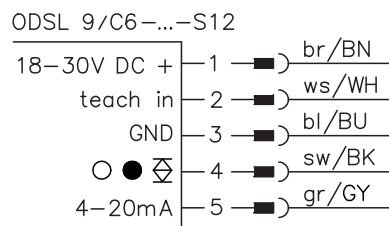
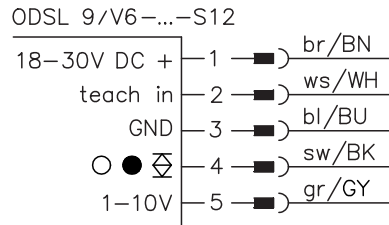

50 ... 450mm

- Reflection-independent distance information
- Highly insensitive to extraneous light
- Analogue current and voltage output
- Measurement value is indicated in mm on LC display
- Teachable switching output and analogue output
- Measurement range and mode adjustable

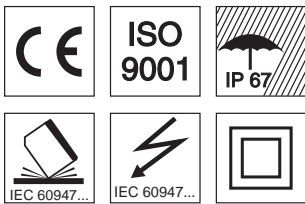

Accessories:

(available separately)

- Mounting systems
- Configuration software
- Cable with M12 connector (K-D ...)

We reserve the right to make changes • DS_ODSL9_C6_V6-450-S12_EN.fm

Specifications

Optical data

Measurement range ¹⁾	50 ... 450mm
Resolution	0.1mm
Light source	laser
Wavelength	655nm
Light spot	divergent, 1x1mm ² at 450mm
Laser warning notice	see remarks

Error limits (relative to measurement distance)

Absolute measurement accuracy ¹⁾	± 1%
Repeatability ²⁾	± 0.5%
b/w detection thresh. (6 ... 90% rem.)	≤ 0.5%
Temperature compensation	yes ³⁾

Timing

Measurement time	2ms ¹⁾
Response time	≤ 6ms
Delay before start-up	≤ 300ms

Electrical data

Operating voltage U_B	18 ... 30VDC (incl. residual ripple)
Residual ripple	≤ 15% of U_B
Open-circuit current	≤ 180mA
Switching output	push-pull switching output ⁴⁾ , PNP light switching, NPN dark switching
Signal voltage high/low	≥ ($U_B - 2V$) / ≤ 2V
Analogue output	voltage 1 ... 10V / 0 ... 10V / 1 ... 5V / 0 ... 5V, $R_L \geq 2k\Omega$ current 4 ... 20mA, $R_L \leq 500\Omega$

Indicators

Green LED	continuous light	teach-in on GND	teach-in on +U_B
	flashing	ready	
	off	fault	teaching procedure
Yellow LED	continuous light	no voltage	
	flashing	object inside teach-in measurement distance	teaching procedure
	off	object outside teach-in measurement distance	

Mechanical data

Housing	plastic
Optics cover	glass
Weight	approx. 50g
Connection type	M12 connector, 5-pin

Environmental data

Ambient temp. (operation/storage)	-20°C ... +50°C / -30°C ... +70°C
Protective circuit ⁵⁾	1, 2, 3
VDE safety class ⁶⁾	II, all-insulated
Protection class	IP 67
Laser class	2 (acc. to EN 60825-1)
Standards applied	IEC 60947-5-2

- 1) Luminosity coefficient 6% ... 90%, complete measurement range, "Standard" operating mode, at 20°C, medium range of U_B , measurement object $\geq 50 \times 50 \text{mm}^2$
- 2) Same object, identical environmental conditions, measurement object $\geq 50 \times 50 \text{mm}^2$
- 3) Typ. $\pm 0.02 \text{ %/K}$
- 4) The push-pull switching outputs must not be connected in parallel
- 5) 1=transient protection, 2=polarity reversal protection, 3=short circuit protection for all outputs
- 6) Rating voltage 50VAC

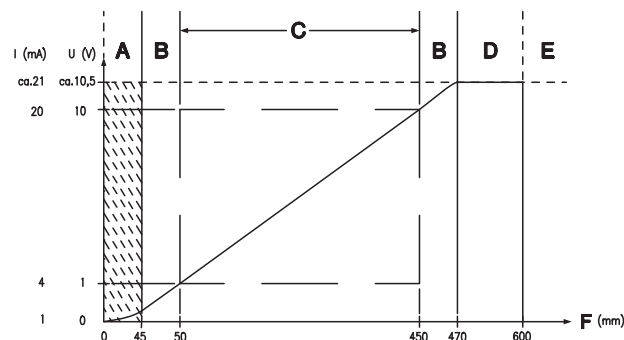

- A** Area not defined
- B** Linearity not defined
- C** Measurement range
- D** Object present
- E** No object detected
- F** Measurement distance

Tables

Diagrams

Remarks

- Measurement time depends on the reflectivity of the measurement object and on the measurement mode.
- **Approved purpose:** The ODSL 9 laser distance sensors are optical electronic sensors for the optical, contactless measurement of distance to objects.

LASER LIGHT	
DO NOT STARE INTO BEAM	
Maximum Output:	1.2mW
Pulse duration:	22ms
Wavelength:	655nm
CLASS 2 LASER PRODUCT	
EN60825-1:2003-10	

Order guide

	Designation	
With M12 connector		
Current output	ODSL 9/C6-450-S12	501 11157
Voltage output	ODSL 9/V6-450-S12	501 11158