

LRT 440

Luminescence scanner

en 07-2010/01 50112990



0 ... 120mm
0 ... 300mm



- Detection of luminescent objects and markings
- Round light spot
- Various filterings
- Large scanning range
- Analog output

Dimensioned drawing

LRT 440...-50-...

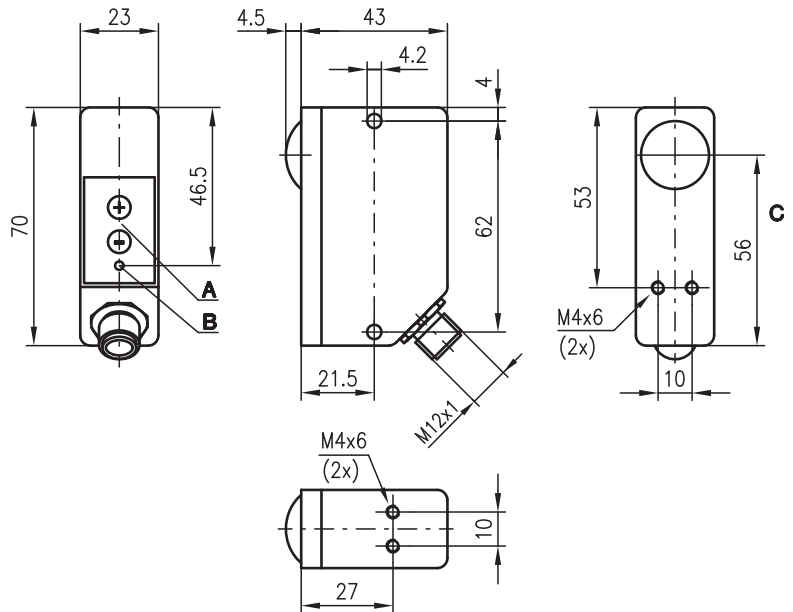

LRT 440...-150-...

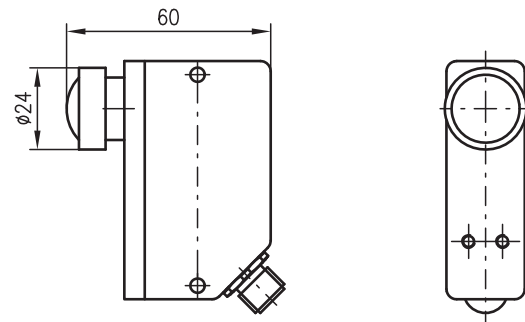

- A** Control button panel
- B** Indicator diode
- C** Optical axis

Electrical connection

without analog output

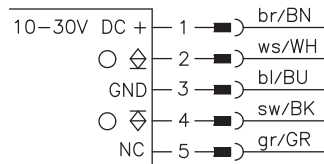

with analog output

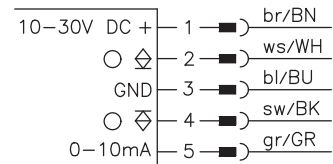

Accessories

(available separately)

- M12 connectors (KD ...)
- Ready-made cables (K-D ...)

We reserve the right to make changes • DS_LRT440_24_en.fm

Specifications

Optical data

Typ. scanning range limit ¹⁾	0 ... 120mm (see diagrams) 0 ... 300mm (see diagrams)
Light spot diameter	see diagrams
Light source	LED
Wavelength	370nm (UV light) 480nm (blue light)
Reception range	450 ... 750nm (with wavelength of 370nm)
Average life ²⁾	≥ 100,000hours

Timing

Switching frequency	600Hz
Response time	0.83ms
Delay before start-up	≤ 200ms

Electrical data

Operating voltage U_B	10 ... 30VDC (incl. residual ripple)
Residual ripple	≤ 15% of U_B
Bias current	≤ 40mA
Switching outputs	1 PNP transistor output 1 NPN transistor output
Analog output	0 ... 10mA (see remarks)
Function characteristics	light switching
Signal voltage high/low	≥ ($U_B - 2V$) / ≤ 2V
Output current	max. 100mA
Sensitivity	adjustable with keyboard (see remarks)

Indicators

LED yellow	reflection
------------	------------

Mechanical data

Housing	diecast zinc
Optics cover	glass
Weight	250g
Connection type	M12 connector, stainless steel, 5-pin

Environmental data

Ambient temp. (operation/storage)	-20°C ... +60°C / -40°C ... +70°C
VDE safety class	III
Protective circuit ³⁾	2, 3
Protection class	IP 67
Standards applied	IEC 60947-5-2

- 1) Typ. scanning range limit: max. attainable range without performance reserve
 2) at +25°C
 3) 2=polarity reversal protection, 3=short-circuit protection for all outputs

Order guide

Selection table		Order code →							
Equipment ↓		LRT 440/24-150-004-S12 Part No. 500 37909	LRT 440/24-50-104-S12 Part No. 500 37910						
Typ. scanning range limit/optics	0 ... 70mm/30mm								
	0 ... 120mm/50mm		●						
	0 ... 300mm/150mm	●							
Luminescence detection of	blue/colorless	●	●						
	red								
	yellow	●	●						
	yellowish green	●	●						
	orange								
Transmitter diode	370nm	●	●						
	470nm								
Analog output			●						

Additional types on request

Tables

Diagrams

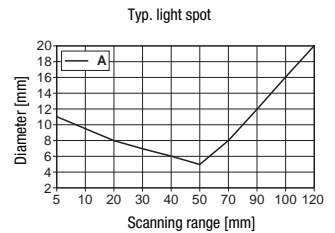

A Optics 50mm

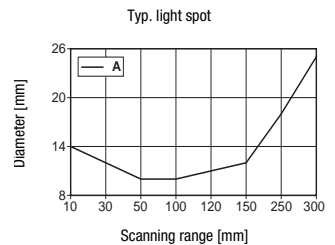

A Optics 150mm

Remarks

- Sensitivity adjustment in 256 steps. Maximum setting by continuously pressing the button for 20sec.
- The analog output is changed by the sensitivity adjustment.
- Additional types on request
 - 6kHz switching frequency
 - Filter variants
 - Analog output
- **Approved purpose:**
 The LRT 440... luminescence scanners are opto-electronic sensors for the optical, contactless detection of luminescent objects. This product may only be used by qualified personnel and must only be used for the approved purpose. This sensor is not a safety sensor and is not to be used for the protection of persons.