



## CRTM 20

## Colour sensors with analogue output



12mm  
20mm  
50mm



- Scanner for colour detection with analogue output
- Red, green, and blue measurement via just one analogue output
- Response time of analogue output: 6.25µs
- Remote changeover of transmitter colours

### Dimensioned drawing

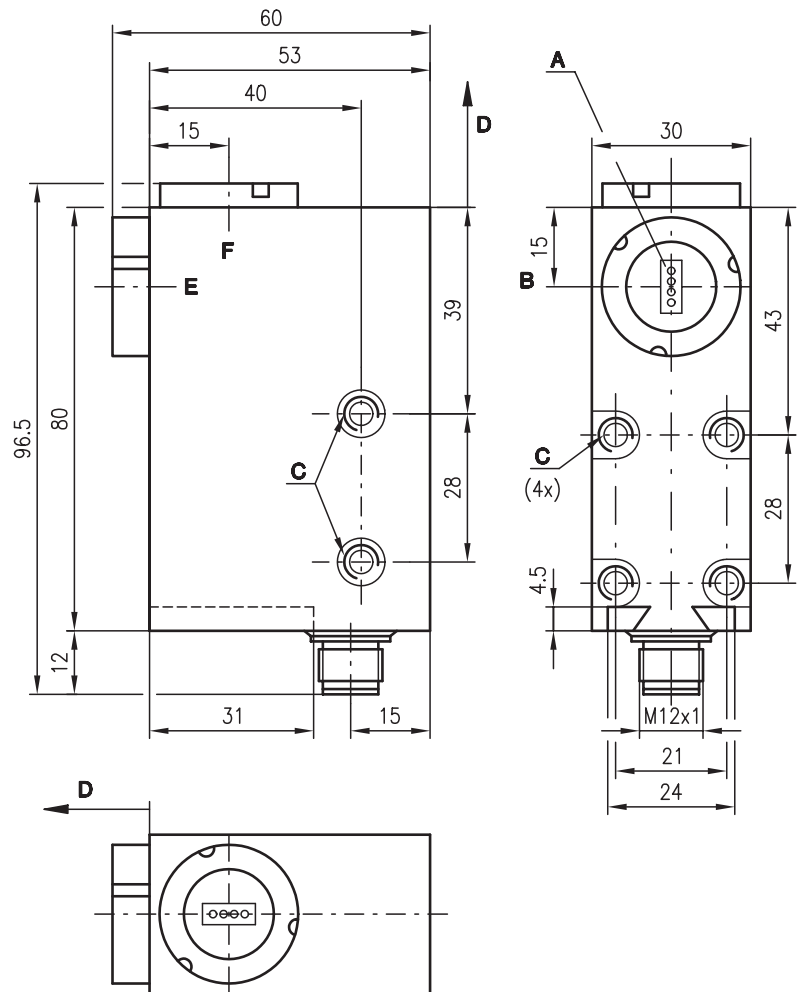

- A Light spot orientation vertical
- B Optical axis
- C M5/5.5mm deep
- D Scanning range
- E Front
- F Head

### Electrical connection

CRTM 20M/V-12-0001-S12  
 CRTM 20M/V-20-0004-S12  
 CRTM 20M/V-50-0001-S12

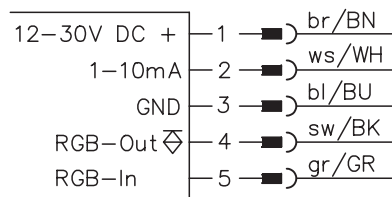

### Accessories:

(available separately)

- M12 connectors, 5-pin (KD ...)
- Ready-made cables (K-D ...)
- Interchangeable objectives
- Tool for changing objectives

We reserve the right to make changes \*fmt\_crt02e.fm



## Specifications

### Optical data

Scanning range with objective 1	12mm ± 5mm (see remarks)
Scanning range with objective 2	20mm ± 5mm (see remarks)
Scanning range with objective 3	50mm ± 5mm (see remarks)
Light spot dimensions with objective 1	3.0mm x 1.0mm
Light spot dimensions with objective 2	4.0mm x 1.2mm
Light spot dimensions with objective 3	10.0mm x 2.0mm
Light spot orientation	vertical or horizontal
Light source	LEDs (red, green, blue)

### Timing

RGB colour changeover	max. 2.5ms per colour change
Response time of analogue output	6.25µs
Delay before start-up	≤ 250ms

### Electrical data

Operating voltage $U_B$	12 ... 30VDC (incl. residual ripple)
Residual ripple	≤ 15% of $U_B$
Analogue output	1 ... 10mA
Signal voltage high/low	≥ ( $U_B - 2V$ ) ≤ 2V
Output current	max. 100mA
Bias current	≤ 60mA

### Indicators

LED green 1	ON "ready"
LED yellow flashing	Q/T "device error" or white calibration

### Mechanical data

Housing	diecast zinc
Optics cover	glass
Weight	300g
Connection type	M12 connector, stainless steel, 5-pin

### Environmental data

Ambient temperature (operation)	-25°C ... +55°C / -40°C ... +70°C
Protection class	IP 67
LED class	1 (acc. to EN 60825-1)
VDE safety class	II
Protective circuit <sup>1)</sup>	2, 3
Standards applied	IEC 60947-5-2

### Options

#### RGB changeover (RGB-In)

Set colour blue (reset)	see signal response
RGB changeover	see signal response

#### RGB feedback (RGB-Out)

PNP or NPN: pulse pause	see signal response
Delay time after changeover	≤ 1ms

1) 2=polarity reversal protection, 3=short-circuit protection for all outputs

## Tables

## Diagrams

## Order guide

See section **Preferred types**

## Remarks

- With shiny objects, the sensor is to be mounted at an angle to the object surface.
- After changing the objective, white calibration is to be performed (see "controls and indicators").



## CRTM 20

### Function principle of the colour sensor

This colour sensor is a device which relays the object colour to the control system via just one analogue output through the use of multiple transmitter colours.

For this purpose, the transmitter colours (red, green, blue) must be changed over. The corresponding colour values (RGB) of the object are then output in sequence at the analogue output.

The control system needs to supply just one analogue input and one digital output. The otherwise standard, three-channel analogue analysis, which requires a considerable amount of hardware, is thus not necessary.

The currently activated transmitter colour is output via RGB-Out.

Each transmitter colour consists of 4 LEDs. An elongated light spot containing four dots is thereby formed at the focal point. In the event that inhomogenous colours are detected, the light spot can be defocused by slightly changing the scanning distance in such a way that a homogenous, rectangular light spot is formed.

### Controls and indicators

LED ON (green) for "Ready"

The Teach, Delay and LD buttons are not active

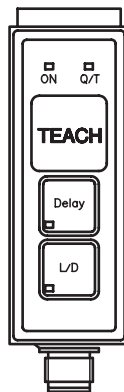

LED Q/T (yellow) "error indicator" (flashing) or white calibration

### Signal propagation

#### Parameterising the transmitter colour via pin 5 (RGB-In)

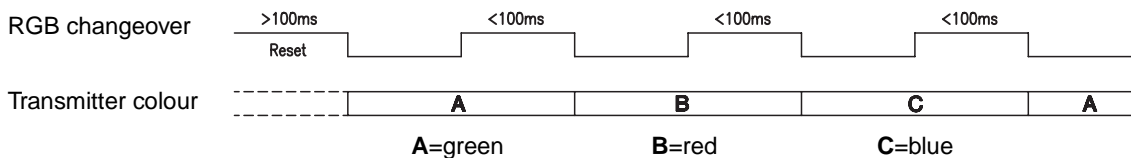

#### Feedback of the transmitter colour via pin 4 (RGB-Out)

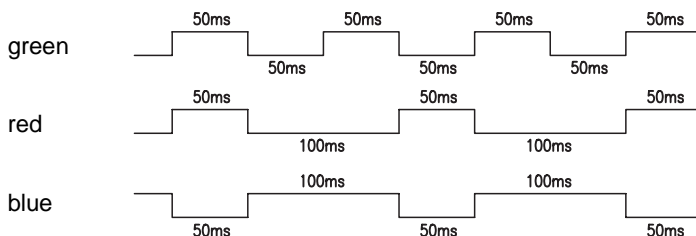

### White calibration

The device is delivered with a 20mm or a 50mm objective. White calibration was performed prior to delivery for these scanning ranges.

12mm, 20mm and 50mm objectives are available. The scanning range and light-spot geometry can, in this way, be adjusted for the given application.

After changing an objective, a new white calibration is useful. This is performed by positioning a piece of white paper (90%) at the appropriate scanning range 12mm, 20mm and 50mm under the light spot. Then press the Delay and L/D buttons together for approx. 5s. The sensor acknowledges the new white calibration by briefly flashing the Q/T LED. Afterward, the entire dynamic range of the sensor is also available for the changed scanning range.



Preferred types

Selection table		Order code →										
Equipment ↓		CRTM 20MV-12-0001-S12 Part No. 501 02166	CRTM 20MV-50-0001-S12 Part No. 500 36094	CRTM 20MV-20-0004-S12 Part No. 501 02847								
Scanning range	12 mm	●										
	20 mm			●								
	50 mm		●									
Transmitter colour	RGB	●	●	●								
	green											
Light spot orientation	vertical	●	●	●								
	horizontal											
	round											
Optical outlet	front			●								
	head	●	●									
Output wiring	PNP	●	●	●								
	NPN											
	analogue voltage											
	analogue current	●	●	●								
Other features	RGB transmitter can be changed over	●	●	●								

Additional types on request