

# L-force

*Three-phase AC motors*



Efficient and precisely tailored

**NEW**

**Lenze**

**This is what we stand for.**

You want to implement your machine and plant concepts efficiently and easily or optimise existing concepts to reduce costs? Then, Lenze is the partner you are looking for. For more than 60 years, drive and automation systems have been our core competence.

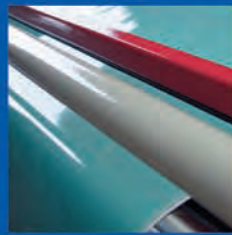
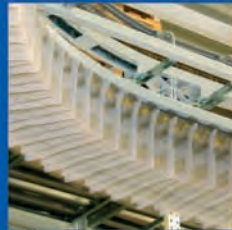
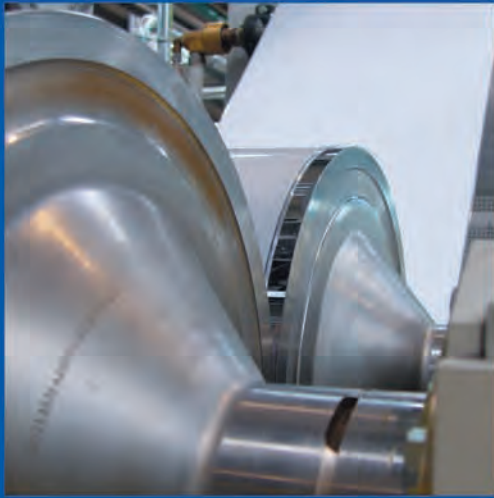
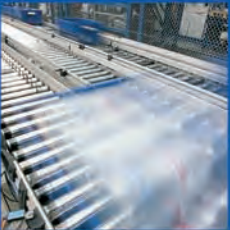
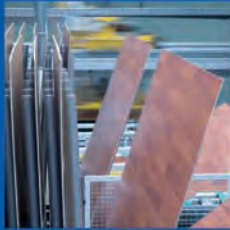

Drive and automation technology set in motion by Lenze – for example in logistics centres, in the textile and printing industry, in the automotive industry or as the driving force behind robots.

# Lenze | about us

We can offer you automation solutions including control, visualisation and drive technology from a single source. Our drive systems will improve the performance of your machines. From project planning to commissioning, we have the know-how, whilst our international sales and service network can provide you with expert help and advice at any time.

Cut your process costs and increase your ability to compete. Let us analyse your drive technology tasks and support you with made-to-measure solutions. We can take an integrated approach to projects thanks to the scalability of our products and the scope of the overall portfolio. We can get the best from your machines and systems.



At your side all over the world – with thorough and professional support from our motivated team.

# L-force | Your future is our drive

Demands are increasing all the time. In future, key challenges will lie in the areas of cost efficiency, time-saving and quality improvements. Faster project planning and commissioning, improved performance and increased flexibility in production are expected. New ideas are therefore needed for the machines of the future.

Lenze has risen to this challenge and, with L-force, we can now not only offer you an innovative family of drive and automation products, but also a new, comprehensive portfolio of solutions.

## **Driven by innovation – new ideas that open up new opportunities**

Always on the lookout. Our idea of innovation is striving for better solutions for our customers every single day.

## **Driven by flexibility – High degree of scalability for individual solutions**

Scalability is an important aspect of the L-force philosophy. Performance, scope of functions, software, service provisions and aftersales care – Lenze will provide you with exactly the combination you require.

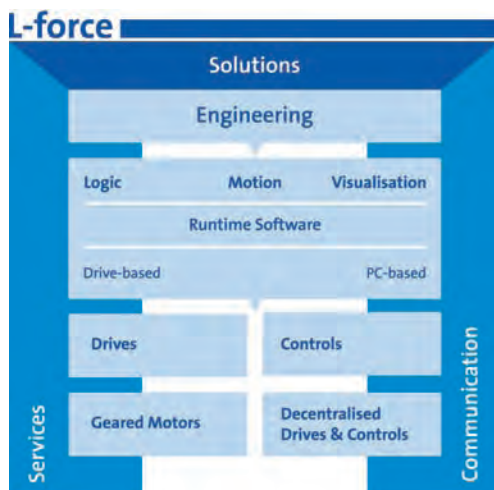

## **Driven by usability – Simple solutions, even for complex applications**

We always focus on the user. Therefore, when we developed L-force, we made sure that people with sufficient practical experience were involved, right from the start.

## **Driven by compatibility – Universal products and solutions**

There is no need to waste time looking for suitable components and the right interfaces. With L-force, every element is perfectly matched.

## **Our drive is "rightsized" – the perfect solution for your application**

We call it Rightsizing: Optimise your processes with the new three-phase AC motors from Lenze and increase your added value.

[www.L-force.de](http://www.L-force.de)

# Contents | Three-phase AC motors



## General information

Product key	8
Product information	9
List of abbreviations	10
Standards and operating conditions	11

## Drive dimensioning

Sizing:	12
Torque derating at low motor frequencies	12
Three-phase AC motor versions	13

## Rated data

Standard efficiency	16
Rated frequency 50 Hz	16
Rated frequency 60 Hz	18
Rated frequency 87 Hz	20
High efficiency (IE2)	21
Rated frequency 50 Hz	21
Rated frequency 60 Hz	22
Rated frequency 87 Hz	23
Permissible radial and axial forces	24
Application of force at I/2	24
Application of force at I	24

# Contents | Three-phase AC motors

## Accessories

Cable glands on terminal box	26
Motor terminal box with ICN connector	28
Motor terminal box with HAN-10 E connector	29
Motor terminal box with HAN modular connector	29
Connector for feedback	30
ICN connector for blower	31
Assignment: Motor – decentralised frequency inverters 8200 motec	32
Spring-applied brake	33
Features	33
Motor – brake assignment	33
Brake connection	35
Permissible friction energy	37
Brake data, reduced braking torque	38
Brake data, standard braking torque	40
Brake data, increased braking torque	42
Blower	44
Blower data 50 Hz	44
Blower data 60 Hz	45
Feedback	46
Resolver	46
Incremental encoder and SinCos absolute value encoder	47
Thermal sensor	48
Thermal contacts	48
PTC thermistor	48
KTY continuous temperature sensor	49

# Contents | Three-phase AC motors

## Dimensions

MDEMA, B3	50
MDEMA, B5	52
MDEMA, B14	54
MDFMA, B3	56
MDFMA, B5	58
MDFMA, B14	60
MHEMA, B3	62
MHEMA, B5	64
MHEMA, B14	66
MHFMA, B3	68
MHFMA, B5	70
MHFMA, B14	72
Motor connection	74
Motor terminal box with ICN connector	74
Motor terminal box with HAN-10E / HAN-Modular connector	75
ICN connector for blower	76
Decentralised frequency inverter 8200 motec	77
Brake motor with manual release lever	79
MD□MA (IE1)	79
MH□MA (IE2)	80

## Surfaces and corrosion protection

OKS-G (primed)	81
OKS-S	81
OKS-M	81
OKS-L	81
Structure of surface coating	82

<b>Lenze world-wide</b>	<b>86</b>
-------------------------	-----------

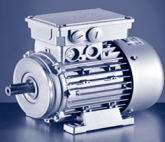

# General information

## Product key

### Three-phase AC motors

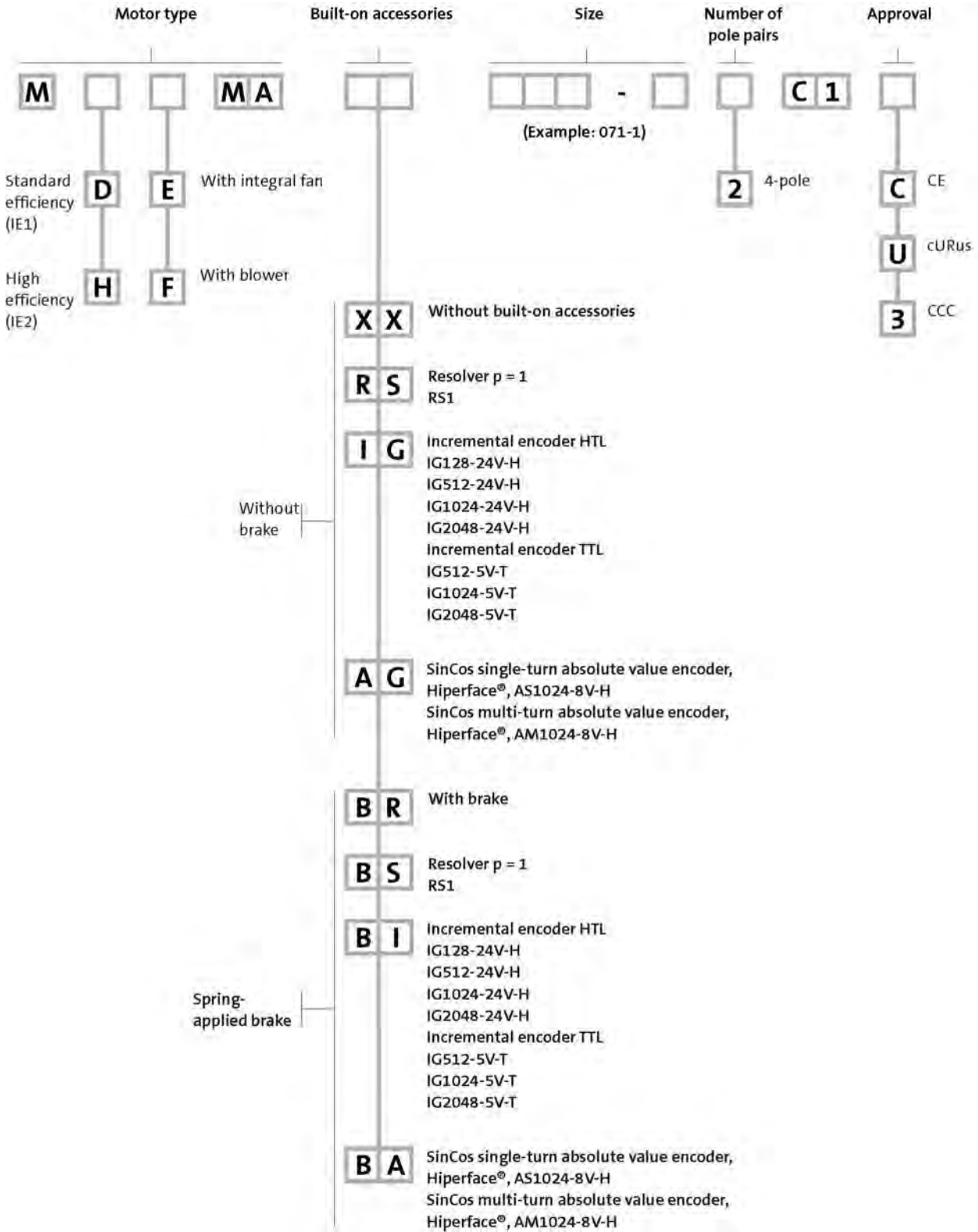



For a long time now, three-phase AC motors from Lenze have been established in virtually all industrial sectors. Based on our many years of experience in the field of drive and automation technology, we have developed a motor, which will ensure that your demands in terms of productivity, quality and availability are perfectly met.

Three-phase AC motors from the L-force series are primarily characterised by their comprehensive modularity. The wide variety of options allows you to precisely adjust the drive characteristics in line with your application. We call this Rightsizing.

- ▶ The 4-pole motors are available in a power range from 0.12 to 30 kW.
- ▶ From a power of 0.75 kW upwards, the motors are available in efficiency classes IE1 and IE2 in accordance with IEC 60034-30.  
Especially important: The highly efficient motors of the IE2 class come in the same sizes as the standard efficiency motors. This makes a changeover especially easy.
- ▶ With the B3, B5 and B14 types of construction as well as the standardised dimensions according to IEC 60072-1 or DIN EN 50347, the motors can be used universally.
- ▶ The motor winding is specially designed for inverter operation.
- ▶ The temperature sensors, which are integrated as a standard feature, enable permanent temperature monitoring and are matched to temperature class F (155°C) of the motor winding.
- ▶ In the basic version, the motors have been adapted to ambient conditions by means of the degree of protection, i.e. IP55.
- ▶ For difficult operating conditions, the surface and corrosion protection system which reliably protects the motor against corrosive media is available.
- ▶ 9 brake sizes – each available with several braking torques – can be combined with three-phase AC motors.
- ▶ The LongLife design of the brake easily enables over  $10 \times 10^6$  switching cycles.
- ▶ For speed and position detection, a resolver and/or various incremental and absolute value encoders can be mounted.
- ▶ Motors are also available with plugs for power connections, brakes, blowers and feedback for fast commissioning.
- ▶ The motor can optionally be equipped with a blower instead of an integral fan. At speeds below 20 Hz, a torque reduction is consequently not required.
- ▶ For drive tasks in distributed applications, the motor can be supplied with the motec frequency inverter mounted on the terminal box.
- ▶ Motors are available with UL/CSA, GOST, CCC and UkrSepro approval.





## General information

### List of abbreviations

$\eta_{100\%}$	[%]	Efficiency, Full load
$\eta_{75\%}$	[%]	Efficiency, Partial load
$\cos \varphi$		Power factor,
$F_{ax}$	[N]	Axial force,
$F_{ax,max}$	[N]	Max. axial force,
$F_{ax,min}$	[N]	Min. axial force,
$F_{rad}$	[N]	Radial force,
$F_{rad,max}$	[N]	Max. radial force,
$I_N$	[A]	Rated current,
$I_{N,\Delta}$	[A]	Rated current, Delta
$I_{N,Y}$	[A]	Rated current, Star
$I_{max}$	[A]	Max. current consumption,
$J$	[kgcm <sup>2</sup> ]	Moment of inertia, Standard
$m$	[kg]	Mass,
$M_a$	[Nm]	Starting torque,
$M_b$	[Nm]	Stalling torque,
$M_{max}$	[Nm]	Max. torque,
$M_N$	[Nm]	Rated torque,
$n_N$	[r/min]	Rated speed,
$P_N$	[kW]	Rated power,
$P_{max}$	[kW]	Max. power input,

CE	Communauté Européenne
CSA	Canadian Standards Association
DIN	Deutsches Institut für Normung e.V.
EMC	Electromagnetic compatibility
EN	European standard
IEC	International Electrotechnical Commission
IM	International Mounting Code
IP	International Protection Code
NEMA	National Electrical Manufacturers Association
UL	Underwriters Laboratory Listed Product
UR	Underwriters Laboratory Recognized Product
VDE	Verband deutscher Elektrotechniker (Association of German Electrical Engineers)
CCC	China Compulsory Certificate
GOST	Certificate for Russian Federation
cURus	Combined certification marks of UL for the USA and Canada
UkrSEPRO	Certificate for Ukraine

$U_{max}$	[V]	Max. mains voltage, AC
$U_{min}$	[V]	Min. mains voltage, AC
$U_{N,\Delta}$	[V]	Rated voltage, Delta
$U_{N,Y}$	[V]	Rated voltage, Star



<b>Enclosure</b> EN 60529			IP55
<b>Energy efficiency class</b> IEC 60034-30			IE1 IE2
<b>Approval Class</b>			CCC cURus <sup>1)</sup> GOST UkrSepro
<b>Temperature class</b> VDE 0530; utilisation VDE 0530; insulation system (enamel-insulated wire)			B F
<b>Vibrational severity</b> EN 60034-14			A
<b>Min. ambient operating temperature</b>	$T_{opr,min}$	[°C]	-20
<b>Max. ambient operating temperature</b> Without power reduction	$T_{opr,max}$	[°C]	40
With power reduction	$T_{opr,max}$	[°C]	60
<b>Max. site altitude above mean sea level</b> Without power reduction	$H_{max}$	[m]	1000
With power reduction	$H_{max}$	[m]	4000

<sup>1)</sup> Motor frame size 160 and 180, in preparation.



# Drive dimensioning

## Sizing:

### Torque derating at low motor frequencies

Torque reduction depending on motor frame size taking into account the thermal behaviour when operated with a frequency inverter.

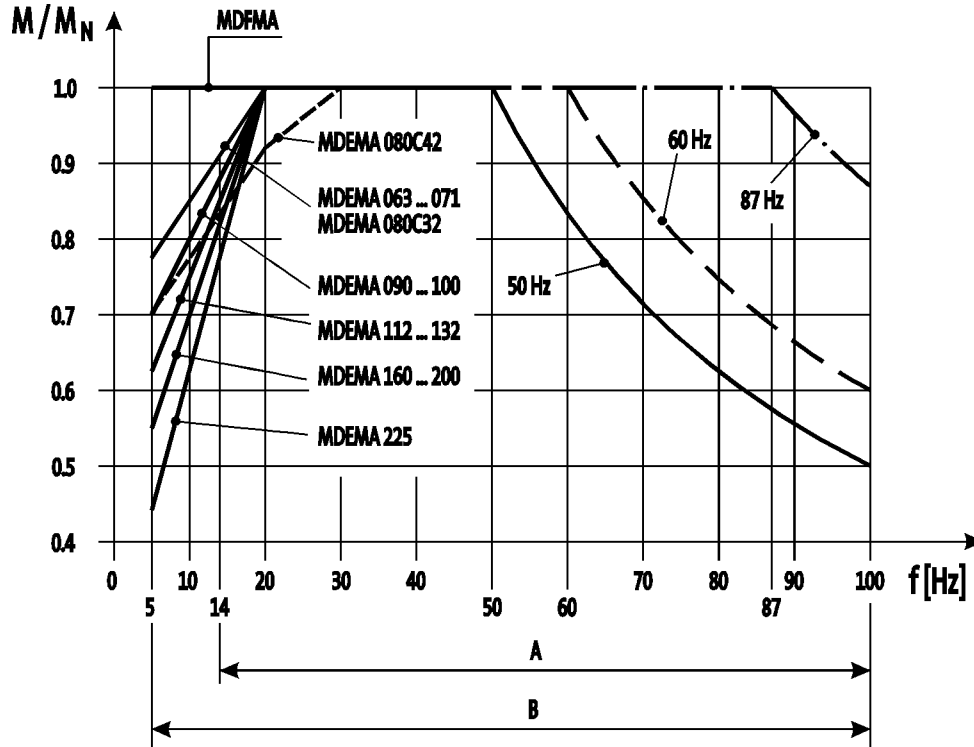

A = Operation with integral fan and brake  
 B = Operation with integral fan and brake control "Holding current reduction"

You can use the Drive Solution Designer for precise drive dimensioning. The Drive Solution Designer helps you to carry out a fast and high-quality drive dimensioning. The software includes well-founded and proven knowledge on drive applications and electro-mechanical drive components.

Please contact your Lenze sales office.

# Drive dimensioning

## Three-phase AC motor versions



		MD□MA□□063-12 MD□MA□□063-32 MD□MA□□063-42	MD□MA□□071-12 MD□MA□□071-32 MD□MA□□071-42	MD□MA□□080-12 MD□MA□□080-32 MD□MA□□080-42 MH□MA□□080-32	MD□MA□□090-12 MD□MA□□090-32 MH□MA□□090-12 MH□MA□□090-32
<b>Type</b>		B14 B3 B5			
<b>Shaft journal</b> d x l	[mm]	11 x 23	14 x 30	19 x 40	24 x 50
<b>Bremse</b> Spring-applied brake		Low noise Reduced, standard or increased braking torque Standard design With manual release lever With rectifier			
<b>Feedback</b>		Resolver Incremental encoder SinCos multi-turn SinCos single-turn			
<b>Thermal sensor</b>		KTY83-110 KTY84-130 PTC Thermal contact			
<b>Motor connection</b> Power connection		Connector ICN HAN modular connector HAN10E connector Terminal box Connector ICN HAN modular connector HAN10E connector Terminal box Connector ICN Terminal box Connector ICN Terminal box Terminal box KTY at connector in the feedback connection Thermal contact or PTC at connector in the power connection			
Brake connection					
Blower connection					
Feedback connection					
Temperature sensor connection					
<b>Shaft bearings</b> Position of the locating bearing		Drive end			
Bearing type		Deep-groove ball bearing with high-temperature resistant grease, 2 sealing discs or cover plates			
<b>Colour</b>		Paint in various corrosion-protection designs in accordance with RAL colours Not coated primed			

# Drive dimensioning

## Three-phase AC motor versions

		MD□MA□□100-12 MD□MA□□100-32 MH□MA□□100-12 MH□MA□□100-32	MD□MA□□112-22 MH□MA□□112-22	MD□MA□□132-12 MD□MA□□132-22 MH□MA□□132-12 MH□MA□□132-22
<b>Type</b>		B14 B3 B5		B3 B5
<b>Shaft journal</b> d x l	[mm]	28 x 60		38 x 80
<b>Bremse</b> Spring-applied brake		Low noise Reduced, standard or increased braking torque Standard design With manual release lever With rectifier		
<b>Feedback</b>		Resolver Incremental encoder SinCos multi-turn SinCos single-turn		
<b>Thermal sensor</b>		KTY83-110 KTY84-130 PTC Thermal contact		
<b>Motor connection</b> Power connection		Connector ICN HAN modular connector HAN10E connector Terminal box		Connector ICN HAN modular connector Terminal box
<b>Brake connection</b>		Connector ICN HAN modular connector HAN10E connector Terminal box		Connector ICN HAN modular connector Terminal box
<b>Blower connection</b>		Connector ICN Terminal box		
<b>Feedback connection</b>		Connector ICN Terminal box		
<b>Temperature sensor connection</b>		Terminal box KTY at connector in the feedback connection Thermal contact or PTC at connector in the power connection		
<b>Shaft bearings</b> Position of the locating bearing		Drive end		
<b>Bearing type</b>		Deep-groove ball bearing with high-temperature resistant grease, 2 sealing discs or cover plates		
<b>Colour</b>		Paint in various corrosion-protection designs in accordance with RAL colours Not coated primed		

# Drive dimensioning

## Three-phase AC motor versions



		MD□MA□□160-22 MD□MA□□160-32 MH□MA□□160-22 MH□MA□□160-32	MD□MA□□180-12 MD□MA□□180-32 MH□MA□□180-12 MH□MA□□180-32	MH□MA□□200-22
<b>Type</b>		B3 B5		
<b>Shaft journal</b> d x l	[mm]	42 x 110	48 x 110	55 x 110
<b>Bremse</b> Spring-applied brake		Low noise Reduced, standard or increased braking torque Standard design With manual release lever With rectifier		
<b>Feedback</b>		Resolver Incremental encoder SinCos multi-turn SinCos single-turn		
<b>Thermal sensor</b>		KTY83-110 KTY84-130 PTC Thermal contact		
<b>Motor connection</b> Power connection		Connector ICN HAN modular connector		Connector ICN
Brake connection		Connector ICN HAN modular connector		Connector ICN
Blower connection			Connector ICN Terminal box	
Feedback connection			Connector ICN Terminal box	
Temperature sensor connection		Terminal box KTY at connector in the feedback connection Thermal contact or PTC at connector in the power connection		Terminal box
<b>Shaft bearings</b> Position of the locating bearing		Drive end		
Bearing type		Deep-groove ball bearing with high-temperature resistant grease, 2 sealing discs or cover plates		
<b>Colour</b>		Paint in various corrosion-protection designs in accordance with RAL colours Not coated primed		



## Rated data

### Standard efficiency

### Rated frequency 50 Hz

	$P_N$	$n_N$	$U_{N, \Delta}^{2)}$	$I_{N, \Delta}$	$U_{N, Y}$	$I_{N, Y}$	$I_a / I_N$
			$\pm 10 \%$		$\pm 10 \%$		
	[kW]	[r/min]	[V]	[A]	[V]	[A]	
MD□MA□□063-12	0.12	1425	230	0.85	400	0.49	3.10
MD□MA□□063-32	0.18	1365	230	1.00	400	0.58	2.70
MD□MA□□063-42	0.25	1370	230	1.40	400	0.82	2.90
MD□MA□□071-12	0.25	1370	230	1.30	400	0.75	2.90
MD□MA□□071-32	0.37	1410	230	1.60	400	0.95	3.30
MD□MA□□071-42	0.55	1405	230	2.40	400	1.40	3.50
MD□MA□□080-12	0.55	1390	230	2.50	400	1.40	3.80
MD□MA□□080-32	0.75	1410	230	3.30	400	1.90	4.60
MD□MA□□080-42	1.10	1390	230	4.80	400	2.80	4.40
MD□MA□□090-12	1.10	1390	230	4.80	400	2.80	4.10
MD□MA□□090-32	1.50	1410	230	6.60	400	3.80	4.80
MD□MA□□100-12	2.20	1440	230	9.20	400	5.30	6.00
MD□MA□□100-32	3.00	1430	230	12.5	400	7.20	4.60
MD□MA□□112-22	4.00	1450	230	16.1	400	9.30	6.20
MD□MA□□132-12	5.50	1450	230 400 <sup>3)</sup>	20.2 11.7	400	11.7	4.00
MD□MA□□132-22	7.50	1455	230 400 <sup>3)</sup>	28.6 16.5	400	16.5	5.90

	$M_N$	$M_a$	$M_b$	$\cos \varphi$	$\eta_{75\%}$	$\eta_{100\%}$	$J^{1)}$	$m^{1)}$
	[Nm]	[Nm]	[Nm]		[%]	[%]	[kgcm <sup>2</sup> ]	[kg]
MD□MA□□063-12	0.80	2.50	2.64	0.56	58.0	63.0	3.30	4.10
MD□MA□□063-32	1.26	2.50	2.61	0.70	63.0	64.0	3.30	4.10
MD□MA□□063-42	1.74	3.80	4.10	0.67	65.0	66.0	3.70	4.40
MD□MA□□071-12	1.74	3.10	3.10	0.75	65.0	66.0	8.30	5.80
MD□MA□□071-32	2.51	4.76	5.81	0.77	73.0	73.0	10.7	5.80
MD□MA□□071-42	3.74	7.85	9.12	0.77	74.0	74.0	12.8	6.40
MD□MA□□080-12	3.80	6.80	7.20	0.80	70.0	70.0	16.9	10.0
MD□MA□□080-32	5.10	11.0	12.1	0.80	73.0	74.0	26.0	11.0
MD□MA□□080-42	7.50	16.5	18.4	0.80	77.0	77.0	26.0	11.0
MD□MA□□090-12	7.56	15.5	16.0	0.81	75.0	75.0	23.2	12.0
MD□MA□□090-32	10.1	23.7	27.1	0.76	78.0	79.0	28.4	15.0
MD□MA□□100-12	14.6	38.0	44.0	0.73	83.0	84.0	61.0	24.0
MD□MA□□100-32	20.5	43.0	50.0	0.75	83.0	83.0	61.0	24.0
MD□MA□□112-22	26.3	70.0	95.0	0.73	85.0	86.0	107	31.0
MD□MA□□132-12	36.2	100	110	0.75	86.0	86.0	188	56.0
MD□MA□□132-22	49.2	100	150	0.76	87.0	88.0	336	66.0

<sup>1)</sup> Without accessories

<sup>2)</sup> Operation at 87 Hz is possible with 4-pole motors whose ratings at 50 Hz include voltage values of  $\Delta$  230 V.  
For motor sizes 132-12 to 180-32, the necessary voltage must also be indicated.

<sup>3)</sup> Star/delta start-up at 400 V possible.

## Rated data Standard efficiency



	$P_N$	$n_N$	$U_{N, \Delta}^{2)}$	$I_{N, \Delta}$	$U_{N, Y}$	$I_{N, Y}$	$I_a / I_N$
			$\pm 10 \%$		$\pm 10 \%$		
	[kW]	[r/min]	[V]	[A]	[V]	[A]	
<b>MD□MA□□160-22</b>	11.0	1460	230 400 <sup>3)</sup>	36.5 21.0	400	21.0	7.00
<b>MD□MA□□160-32</b>	15.0	1460	230 400 <sup>3)</sup>	48.4 27.8	400	27.8	7.10
<b>MD□MA□□180-12</b>	18.5	1470	230 400 <sup>3)</sup>	57.8 32.8	400	32.8	6.80
<b>MD□MA□□180-32</b>	22.0	1465	230 400 <sup>3)</sup>	67.4 38.8	400	38.8	7.30

	$M_N$	$M_a$	$M_b$	$\cos \varphi$	$\eta_{75 \%}$	$\eta_{100 \%}$	$J^{1)}$	$m^{1)}$
	[Nm]	[Nm]	[Nm]		[%]	[%]	[kgcm <sup>2</sup> ]	[kg]
<b>MD□MA□□160-22</b>	71.9	150	204	0.85	89.2	89.0	610	110
<b>MD□MA□□160-32</b>	98.1	214	288	0.87	89.7	90.0	750	130
<b>MD□MA□□180-12</b>	120	260	313	0.90	90.7	90.5	1350	165
<b>MD□MA□□180-32</b>	144	330	360	0.90	91.2	91.0	1550	175

<sup>1)</sup> Without accessories

<sup>2)</sup> Operation at 87 Hz is possible with 4-pole motors whose ratings at 50 Hz include voltage values of  $\Delta$  230 V.

For motor sizes 132-12 to 180-32, the necessary voltage must also be indicated.

<sup>3)</sup> Star/delta start-up at 400 V possible.



## Rated data

### Standard efficiency

#### Rated frequency 60 Hz

	$P_N$	$n_N$	$U_{N, \Delta}^{2)}$	$I_{N, \Delta}$	$U_{N, Y}$	$I_{N, Y}$	$I_a / I_N$
			$\pm 10 \%$		$\pm 10 \%$		
	[kW]	[r/min]	[V]	[A]	[V]	[A]	
MD□MA□□063-12	0.14	1725	277	0.85	480	0.49	3.10
MD□MA□□063-32	0.22	1665	277	1.00	480	0.58	2.70
MD□MA□□063-42	0.31	1670	277	1.40	480	0.82	2.90
MD□MA□□071-12	0.31	1670	277	1.30	480	0.75	2.90
MD□MA□□071-32	0.45	1710	277	1.60	480	0.95	3.30
MD□MA□□071-42	0.68	1705	277	2.40	480	1.40	3.50
MD□MA□□080-12	0.68	1690	277	2.40	480	1.40	3.80
MD□MA□□080-32	0.92	1710	277	3.30	480	1.90	5.10
MD□MA□□080-42	1.30	1690	277	4.80	480	2.80	5.00
MD□MA□□090-12	1.30	1690	277	4.80	480	2.80	4.10
MD□MA□□090-32	1.80	1710	277	6.60	480	3.80	5.30
MD□MA□□100-12	2.60	1740	277	9.20	480	5.30	6.60
MD□MA□□100-32	3.60	1730	277	12.5	480	7.20	5.20
MD□MA□□112-22	4.80	1750	277	16.1	480	9.30	6.40
MD□MA□□132-12	6.60	1750	277 480 <sup>3)</sup>	20.2 11.7	480	11.7	4.20
MD□MA□□132-22	9.00	1755	277 480 <sup>3)</sup>	28.6 16.5	480	16.5	6.50

	$M_N$	$M_a$	$M_b$	$\cos \varphi$	$\eta_{75\%}$	$\eta_{100\%}$	$J^{1)}$	$m^{1)}$
	[Nm]	[Nm]	[Nm]		[%]	[%]	[kgcm <sup>2</sup> ]	[kg]
MD□MA□□063-12	0.80	2.50	2.60	0.56	58.0	63.0	3.30	4.10
MD□MA□□063-32	1.30	2.50	2.60	0.70	63.0	64.0	3.30	4.10
MD□MA□□063-42	1.80	3.90	4.20	0.67	64.0	66.0	3.70	4.40
MD□MA□□071-12	1.74	3.40	4.20	0.75	65.0	66.0	8.30	5.80
MD□MA□□071-32	2.51	4.80	5.80	0.77	74.0	73.0	10.7	5.80
MD□MA□□071-42	3.74	8.00	9.30	0.77	76.0	74.0	12.8	6.40
MD□MA□□080-12	3.80	8.10	9.10	0.80	74.0	75.0	16.9	10.0
MD□MA□□080-32	5.10	11.6	13.3	0.80	79.0	79.0	26.0	11.0
MD□MA□□080-42	7.50	17.8	21.0	0.80	79.0	79.0	26.0	11.0
MD□MA□□090-12	7.56	21.8	23.1	0.80	79.0	79.0	23.2	12.0
MD□MA□□090-32	10.1	24.7	30.2	0.74	80.0	82.0	28.4	15.0
MD□MA□□100-12	14.6	38.0	47.0	0.73	84.0	85.0	61.0	24.0
MD□MA□□100-32	20.5	43.0	54.0	0.75	87.0	88.0	61.0	24.0
MD□MA□□112-22	26.4	58.0	102	0.73	86.0	87.0	107	31.0
MD□MA□□132-12	36.2	100	115	0.79	87.0	88.0	188	56.0
MD□MA□□132-22	49.2	100	160	0.75	88.0	88.0	336	66.0

<sup>1)</sup> Without accessories

<sup>2)</sup> Operation at 87 Hz is possible with 4-pole motors whose ratings at 60 Hz include voltage values of  $\Delta$  277 V.  
For motor sizes 132-12 to 180-32, the necessary voltage must also be indicated.

<sup>3)</sup> Star/delta start-up at 480 V possible.

## Rated data Standard efficiency



	$P_N$	$n_N$	$U_{N, \Delta}^{2)}$	$I_{N, \Delta}$	$U_{N, Y}$	$I_{N, Y}$	$I_a / I_N$
			$\pm 10 \%$		$\pm 10 \%$		
	[kW]	[r/min]	[V]	[A]	[V]	[A]	
<b>MD□MA□□160-22</b>	13.2	1760	277 480 <sup>3)</sup>	36.5 21.0	480	21.0	7.00
<b>MD□MA□□160-32</b>	18.0	1760	277 480 <sup>3)</sup>	48.4 27.8	480	27.8	7.10
<b>MD□MA□□180-12</b>	22.2	1770	277 480 <sup>3)</sup>	57.8 32.8	480	32.8	6.80
<b>MD□MA□□180-32</b>	26.4	1765	277 480 <sup>3)</sup>	67.4 38.8	480	38.8	7.30

	$M_N$	$M_a$	$M_b$	$\cos \varphi$	$\eta_{75 \%}$	$\eta_{100 \%}$	$J^{1)}$	$m^{1)}$
	[Nm]	[Nm]	[Nm]		[%]	[%]	[kgcm <sup>2</sup> ]	[kg]
<b>MD□MA□□160-22</b>	71.9	150	204	0.85	90.1	89.0	610	110
<b>MD□MA□□160-32</b>	98.1	214	288	0.87	90.6	90.0	750	130
<b>MD□MA□□180-12</b>	120	260	313	0.90	91.5	90.5	1350	165
<b>MD□MA□□180-32</b>	144	330	360	0.90	92.0	91.0	1550	175

<sup>1)</sup> Without accessories

<sup>2)</sup> Operation at 87 Hz is possible with 4-pole motors whose ratings at 60 Hz include voltage values of  $\Delta$  277 V.

For motor sizes 132-12 to 180-32, the necessary voltage must also be indicated.

<sup>3)</sup> Star/delta start-up at 480 V possible.

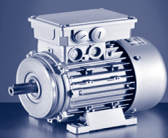

## Rated data

### Standard efficiency

#### Rated frequency 87 Hz

	$P_N$	$n_N$	$M_N$	$M_{max}$	$U_{N, \Delta}$	$I_{N, \Delta}$	$\cos \varphi$	$\eta_{75\%}$	$\eta_{100\%}$	$J^{1)}$	$m^{1)}$
					$\pm 10\%$						
	[kW]	[r/min]	[Nm]	[Nm]	[V]	[A]		[%]	[%]	[kgcm <sup>2</sup> ]	[kg]
<b>MD□MA□□063-12</b>	0.21	2535	0.80	1.60	400	0.85	0.55	61.0	68.0	3.30	4.10
<b>MD□MA□□063-32</b>	0.33	2475	1.26	5.00	400	1.00	0.65	68.0	70.0	3.30	4.10
<b>MD□MA□□063-42</b>	0.45	2480	1.74	7.00	400	1.40	0.63	66.0	69.0	3.70	4.40
<b>MD□MA□□071-12</b>	0.45	2480	1.74	7.00	400	1.30	0.74	66.0	68.0	8.30	5.80
<b>MD□MA□□071-32</b>	0.66	2520	2.51	10.0	400	1.60	0.72	76.0	78.0	10.7	5.80
<b>MD□MA□□071-42</b>	1.00	2515	3.74	15.0	400	2.40	0.74	79.0	80.0	12.8	6.40
<b>MD□MA□□080-12</b>	1.00	2500	3.80	15.0	400	2.50	0.78	72.0	72.0	16.9	10.0
<b>MD□MA□□080-32</b>	1.35	2520	5.10	20.0	400	3.30	0.80	75.0	77.0	26.0	11.0
<b>MD□MA□□080-42</b>	2.00	2500	7.50	30.0	400	4.80	0.80	81.0	82.0	26.0	11.0
<b>MD□MA□□090-12</b>	2.00	2500	7.56	30.0	400	4.80	0.78	77.0	77.0	23.2	12.0
<b>MD□MA□□090-32</b>	2.70	2520	10.1	40.0	400	6.70	0.73	83.0	85.0	28.4	15.0
<b>MD□MA□□100-12</b>	3.90	2550	14.6	60.0	400	9.20	0.71	87.0	88.0	61.0	24.0
<b>MD□MA□□100-32</b>	5.40	2540	20.5	80.0	400	12.5	0.73	87.0	88.0	61.0	24.0
<b>MD□MA□□112-22</b>	7.10	2560	26.3	105	400	16.1	0.71	87.0	88.0	107	31.0
<b>MD□MA□□132-12</b>	9.70	2560	36.2	145	400	20.1	0.78	90.0	90.0	188	56.0
<b>MD□MA□□132-22</b>	13.2	2565	49.2	200	400	28.6	0.75	90.0	90.0	336	66.0
<b>MD□MA□□160-22</b>	19.3	2565	71.9	280	400	36.5	0.85	91.7	90.0	610	110
<b>MD□MA□□160-32</b>	26.4	2565	98.1	390	400	48.4	0.86	91.9	92.0	750	130
<b>MD□MA□□180-12</b>	32.4	2575	120	480	400	57.8	0.89	92.8	92.0	1350	165
<b>MD□MA□□180-32</b>	38.7	2560	144	572	400	67.4	0.89	92.8	92.0	1550	175

<sup>1)</sup> Without accessories

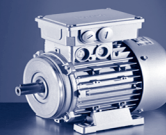

## Rated frequency 50 Hz

	$P_N$	$n_N$	$U_{N, \Delta}^{-1)}$	$I_{N, \Delta}$	$U_{N, Y}$	$I_{N, Y}$	$I_a / I_N$
			$\pm 10 \%$		$\pm 10 \%$		
	[kW]	[r/min]	[V]	[A]	[V]	[A]	
MH□MA□□080-32	0.75	1410	230	3.10	400	1.80	5.00
MH□MA□□090-12	1.10	1430	230	4.60	400	2.70	5.40
MH□MA□□090-32	1.50	1435	230	5.80	400	3.30	6.30
MH□MA□□100-12	2.20	1445	230	8.60	400	5.00	6.00
MH□MA□□100-32	3.00	1445	230	12.1	400	7.00	6.50
MH□MA□□112-22	4.00	1455	230	14.5	400	8.40	6.00
MH□MA□□132-12	5.50	1470	230 400 <sup>3)</sup>	20.6 11.9	400	11.9	6.10
MH□MA□□132-22	7.50	1460	230 400 <sup>3)</sup>	27.0 15.6	400	15.6	8.50
MH□MA□□160-22	11.0	1470	230 400 <sup>3)</sup>	37.7 21.8	400	21.8	8.00
MH□MA□□160-32	15.0	1470	230 400 <sup>3)</sup>	50.3 29.1	400	29.1	8.20
MH□MA□□180-12	18.5	1475	230 400 <sup>3)</sup>	58.8 34.0	400	34.0	8.40
MH□MA□□180-32	22.0	1470	230 400 <sup>3)</sup>	68.9 39.8	400	39.8	7.80
MH□MA□□200-22	30.0	1465	230 400 <sup>3)</sup>	93.8 53.9	400	53.9	7.00

	$M_N$	$M_a$	$M_b$	$\cos \varphi$	$\eta_{75\%}$	$\eta_{100\%}$	$J^{1)}$	$m^{1)}$
	[Nm]	[Nm]	[Nm]		[%]	[%]	[kgcm <sup>2</sup> ]	[kg]
MH□MA□□080-32	5.08	12.0	12.1	0.84	79.6	79.6	28.0	11.0
MH□MA□□090-12	7.35	20.3	24.2	0.76	81.6	82.0	32.0	16.0
MH□MA□□090-32	10.0	33.0	34.0	0.76	83.4	82.8	36.0	18.0
MH□MA□□100-12	14.5	48.0	55.0	0.80	86.7	86.3	61.0	24.0
MH□MA□□100-32	19.8	67.0	76.0	0.73	85.6	85.5	66.0	26.5
MH□MA□□112-22	26.3	81.0	100	0.80	88.2	88.3	135	38.0
MH□MA□□132-12	35.7	90.0	108	0.77	89.3	89.2	290	66.0
MH□MA□□132-22	49.1	110	175	0.79	88.9	88.7	336	66.0
MH□MA□□160-22	71.5	164	243	0.82	89.8	89.8	570	109
MH□MA□□160-32	97.4	224	292	0.82	90.6	90.6	760	124
MH□MA□□180-12	120	359	371	0.86	91.2	91.2	1390	175
MH□MA□□180-32	143	400	372	0.87	91.6	91.6	1440	180
MH□MA□□200-22	196	469	469	0.87	92.3	92.3	1850	315

<sup>1)</sup> Without accessories

<sup>2)</sup> Operation at 87 Hz is possible with 4-pole motors whose ratings at 50 Hz include voltage values of  $\Delta$  230 V.

For motor sizes 132-12 to 200-22, the necessary voltage must also be indicated.

<sup>3)</sup> Star/delta start-up at 400 V possible.



## Rated data

### High efficiency (IE2)

#### Rated frequency 60 Hz

	$P_N$	$n_N$	$U_{N,\Delta}^{-1)}$	$I_{N,\Delta}$	$U_{N,Y}$	$I_{N,Y}$	$I_a / I_N$
			$\pm 10\%$		$\pm 10\%$		
	[kW]	[r/min]	[V]	[A]	[V]	[A]	
MH□MA□□080-32	0.92	1710	277	3.10	480	1.80	5.40
MH□MA□□090-12	1.30	1730	277	4.60	480	2.70	5.80
MH□MA□□090-32	1.80	1735	277	5.80	480	3.30	6.70
MH□MA□□100-12	2.60	1745	277	8.60	480	5.00	6.40
MH□MA□□100-32	3.60	1745	277	12.1	480	7.00	7.00
MH□MA□□112-22	4.80	1755	277	14.5	480	8.40	6.40
MH□MA□□132-12	6.60	1770	277 480 <sup>3)</sup>	20.6 11.9	480	11.9	6.50
MH□MA□□132-22	9.00	1760	277 480 <sup>3)</sup>	27.0 15.6	480	15.6	9.10
MH□MA□□160-22	13.2	1770	277 480 <sup>3)</sup>	37.7 21.8	480	21.8	8.60
MH□MA□□160-32	18.0	1770	277 480 <sup>3)</sup>	50.3 29.1	480	29.1	9.10
MH□MA□□180-12	22.2	1775	277 480 <sup>3)</sup>	58.8 34.0	480	34.0	8.90
MH□MA□□180-32	26.4	1770	277 480 <sup>3)</sup>	68.9 39.8	480	39.8	8.20
MH□MA□□200-22	36.0	1765	277 480 <sup>3)</sup>	93.8 53.9	480	53.9	7.40

	$M_N$	$M_a$	$M_b$	$\cos \varphi$	$\eta_{75\%}$	$\eta_{100\%}$	$J^{1)}$	$m^{1)}$
	[Nm]	[Nm]	[Nm]		[%]	[%]	[kgcm <sup>2</sup> ]	[kg]
MH□MA□□080-32	5.14	12.6	13.3	0.84	82.5	82.5	28.0	11.0
MH□MA□□090-12	7.18	22.0	26.0	0.76	84.0	84.0	32.0	16.0
MH□MA□□090-32	9.91	35.0	37.0	0.76	84.3	84.0	36.0	18.0
MH□MA□□100-12	14.2	52.0	60.0	0.80	87.5	87.5	61.0	24.0
MH□MA□□100-32	19.7	73.0	84.0	0.73	87.8	87.5	66.0	26.5
MH□MA□□112-22	26.1	90.0	110	0.80	89.5	89.5	135	38.0
MH□MA□□132-12	35.6	97.0	120	0.77	89.5	90.3	290	66.0
MH□MA□□132-22	48.8	120	192	0.79	89.5	89.5	336	66.0
MH□MA□□160-22	71.2	171	256	0.81	90.9	90.9	570	109
MH□MA□□160-32	97.1	243	301	0.82	91.3	91.3	760	124
MH□MA□□180-12	119	370	382	0.86	91.8	91.8	1390	175
MH□MA□□180-32	142	413	384	0.87	92.3	92.3	1440	180
MH□MA□□200-22	195	487	604	0.87	92.7	92.7	1850	315

<sup>1)</sup> Without accessories

<sup>2)</sup> Operation at 87 Hz is possible with 4-pole motors whose ratings at 60 Hz include voltage values of  $\Delta$  277 V.

For motor sizes 132-12 to 200-22, the necessary voltage must also be indicated.

<sup>3)</sup> Star/delta start-up at 480 V possible.



### Rated frequency 87 Hz

	$P_N$	$n_N$	$M_N$	$M_{max}$	$U_{N, \Delta}$	$I_{N, \Delta}$	$\cos \varphi$	$\eta_{75\%}$	$\eta_{100\%}$	J	m
					$\pm 10\%$						
	[kW]	[r/min]	[Nm]	[Nm]	[V]	[A]		[%]	[%]	[kgcm <sup>2</sup> ]	[kg]
<b>MH□MA□□080-32</b>	1.35	2520	5.12	20.0	400	3.10	0.84	81.6	83.5	28.0	11.0
<b>MH□MA□□090-12</b>	2.00	2540	7.52	30.0	400	4.60	0.78	54.9	86.5	32.0	16.0
<b>MH□MA□□090-32</b>	2.70	2545	10.1	40.0	400	5.80	0.76	85.5	86.0	36.0	18.0
<b>MH□MA□□100-12</b>	3.90	2555	14.6	60.0	400	8.60	0.83	89.6	90.0	61.0	24.0
<b>MH□MA□□100-32</b>	5.40	2555	20.2	80.0	400	12.1	0.76	87.9	88.5	66.0	26.5
<b>MH□MA□□112-22</b>	7.10	2565	26.4	106	400	14.5	0.83	90.2	90.9	135	38.0
<b>MH□MA□□132-12</b>	9.70	2580	35.9	144	400	20.6	0.82	91.4	91.8	290	66.0
<b>MH□MA□□132-22</b>	13.2	2570	49.1	196	400	27.0	0.82	90.1	90.7	336	66.0
<b>MH□MA□□160-22</b>	19.4	2580	71.8	287	400	37.7	0.81	91.6	91.6	570	109
<b>MH□MA□□160-32</b>	26.4	2580	97.7	391	400	50.3	0.81	91.6	91.6	760	124
<b>MH□MA□□180-12</b>	32.5	2585	120	480	400	58.8	0.86	92.8	92.8	1390	175
<b>MH□MA□□180-32</b>	38.7	2580	143	573	400	68.9	0.87	93.4	93.4	1440	180
<b>MH□MA□□200-22</b>	52.7	2575	196	782	400	93.8	0.87	93.2	93.2	1850	315

<sup>1)</sup> Without accessories



## Rated data

### Permissible radial and axial forces

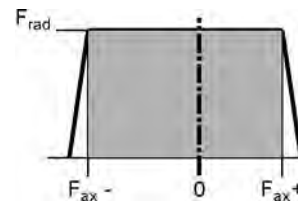
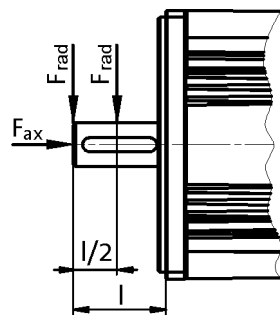

#### Application of force at $l/2$

	Bearing service life $L_{10}$											
	10000 h			20000 h			30000 h			50000 h		
	$F_{rad,max}$	$F_{ax,min}$	$F_{ax,max}$	$F_{rad,max}$	$F_{ax,min}$	$F_{ax,max}$	$F_{rad,max}$	$F_{ax,min}$	$F_{ax,max}$	$F_{rad,max}$	$F_{ax,min}$	$F_{ax,max}$
	[N]	[N]	[N]	[N]	[N]	[N]	[N]	[N]	[N]	[N]	[N]	[N]
<b>063</b>	<b>600</b>	-600	300	<b>470</b>	-480	180	<b>410</b>	-430	120	<b>350</b>	-370	70
<b>071</b>	<b>740</b>	-800	470	<b>590</b>	-630	300	<b>510</b>	-550	220	<b>430</b>	-470	140
<b>080</b>	<b>960</b>	-1090	580	<b>770</b>	-860	350	<b>670</b>	-760	250	<b>570</b>	-650	140
<b>090</b>	<b>1050</b>	-1160	630	<b>840</b>	-920	390	<b>730</b>	-800	280	<b>620</b>	-690	160
<b>100</b>	<b>1490</b>	-1490	910	<b>1190</b>	-1160	580	<b>1050</b>	-1010	430	<b>890</b>	-860	270
<b>112</b>	<b>2250</b>	-2330	1340	<b>1790</b>	-1830	840	<b>1570</b>	-1600	610	<b>1330</b>	-1360	370
<b>132</b>	<b>3300</b>	-2150	1190	<b>2640</b>	-1670	710	<b>2320</b>	-1440	480	<b>1970</b>	-1210	250
<b>160</b>	<b>3750</b>	-2700	1520	<b>3000</b>	-2130	950	<b>2640</b>	-1830	670	<b>2250</b>	-1440	360
<b>180</b>	<b>5620</b>	-3270	1790	<b>4500</b>	-2580	1120	<b>3960</b>	-2210	790	<b>3375</b>	-1750	420
<b>200</b>	<b>5620</b>	-3270	1790	<b>4500</b>	-2580	1120	<b>3960</b>	-2210	790	<b>3375</b>	-1750	420

#### Application of force at $l$

	Bearing service life $L_{10}$											
	10000 h			20000 h			30000 h			50000 h		
	$F_{rad,max}$	$F_{ax,min}$	$F_{ax,max}$	$F_{rad,max}$	$F_{ax,min}$	$F_{ax,max}$	$F_{rad,max}$	$F_{ax,min}$	$F_{ax,max}$	$F_{rad,max}$	$F_{ax,min}$	$F_{ax,max}$
	[N]	[N]	[N]	[N]	[N]	[N]	[N]	[N]	[N]	[N]	[N]	[N]
<b>063</b>	<b>400</b>	-600	300	<b>370</b>	-480	180	<b>320</b>	-430	120	<b>300</b>	-370	70
<b>071</b>	<b>680</b>	-800	470	<b>540</b>	-630	300	<b>470</b>	-550	220	<b>400</b>	-470	140
<b>080</b>	<b>880</b>	-1090	580	<b>700</b>	-860	350	<b>610</b>	-760	250	<b>520</b>	-650	140
<b>090</b>	<b>940</b>	-1160	630	<b>750</b>	-920	390	<b>660</b>	-800	280	<b>560</b>	-690	160
<b>100</b>	<b>1350</b>	-1490	910	<b>1080</b>	-1160	580	<b>940</b>	-1010	430	<b>800</b>	-860	270
<b>112</b>	<b>2040</b>	-2330	1340	<b>1620</b>	-1830	840	<b>1420</b>	-1600	610	<b>1210</b>	-1360	370
<b>132</b>	<b>3020</b>	-2150	1190	<b>2420</b>	-1670	710	<b>2120</b>	-1440	480	<b>1800</b>	-1210	250
<b>160</b>	<b>3410</b>	-2700	1520	<b>2730</b>	-2130	950	<b>2400</b>	-1830	670	<b>2050</b>	-1440	360
<b>180</b>	<b>4550</b>	-3270	1790	<b>3640</b>	-2580	1120	<b>3200</b>	-2210	790	<b>2730</b>	-1750	420
<b>200</b>	<b>4550</b>	-3270	1790	<b>3640</b>	-2580	1120	<b>3200</b>	-2210	790	<b>2730</b>	-1750	420

- ▶ The values for the bearing service life  $L_{10}$  refer to an average speed of 2000 rpm. Depending on the ambient temperatures, the service life of the bearings is also reduced by the grease lifetime.
- ▶ Data for axial forces relate to the maximum radial force with the corresponding bearing service life.

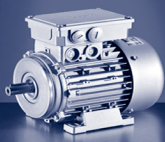

## Accessories

### Motor connection

The three-phase motors are intended for operation from a constant mains supply or in conjunction with an inverter. For 50 Hz operation, the motors are to be operated in a  $\Delta$ -circuit at 230 V or in a Y circuit at 400 V. For inverter operation, the base frequency has been specified as 87 Hz at a rated voltage of 400 V in a  $\Delta$ -circuit.

In the standard version, the motors are connected in the terminal box. As an option, the motors are also available with the plug-in connectors described on the following pages as long as the permissible ratings are not exceeded.

### Cable glands on terminal box

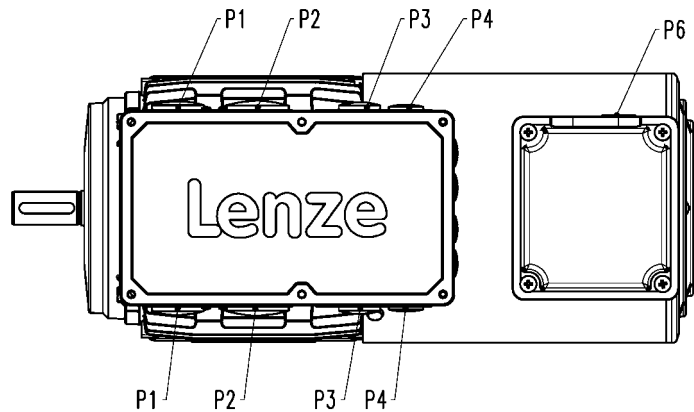

Motor type	MDEMAXX MDEMABR MDEMARS MDEMAIG MDEMAAG MHEMAXX MHEMABR MHEMARS MHEMAIG MHEMAAG				MDEMABS MDEMABI MDEMABA MHEMABS MHEMABI MHEMABA			
	P <sub>1</sub>	P <sub>2</sub>	P <sub>3</sub>	P <sub>4</sub>	P <sub>1</sub>	P <sub>2</sub>	P <sub>3</sub>	P <sub>4</sub>
	[mm]	[mm]	[mm]	[mm]	[mm]	[mm]	[mm]	[mm]
063	M16x1.5	M20x1.5						
071								
080	M20x1.5	M25x1.5			M25x1.5	M32x1.5	M20x1.5	M16x1.5
090								
100								
112	M25x1.5	M32x1.5	M20x1.5	M16x1.5	M50x1.5	M16x1.5		
132								
160	M50x1.5	M16x1.5						
180								
200								

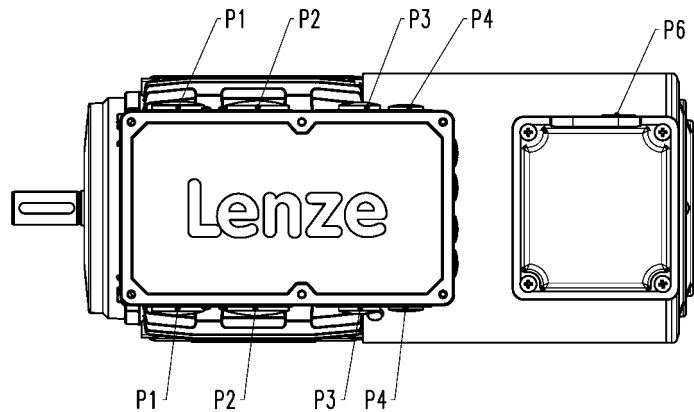

Motor type	MDFMAXX MDFMABR MDFMARS MDFMAIG MDFMAAG MHFMAXX MHFMABR MHFMARS MHFMAIG MHFMAAG					MDFMABS MDFMABI MDFMABA MHFMABS MHFMABI MHFMABA				
	P <sub>1</sub> [mm]	P <sub>2</sub> [mm]	P <sub>3</sub> [mm]	P <sub>4</sub> [mm]	P <sub>6</sub> [mm]	P <sub>1</sub> [mm]	P <sub>2</sub> [mm]	P <sub>3</sub> [mm]	P <sub>4</sub> [mm]	P <sub>6</sub> [mm]
063	M16x1.5	M20x1.5								
071										
080										
090	M20x1.5	M25x1.5				M25x1.5	M32x1.5			
100					M16x1.5			M20x1.5	M16x1.5	M16x1.5
112										
132	M25x1.5	M32x1.5								
160										
180	M50x1.5	M16x1.5	M20x1.5	M16x1.5		M50x1.5	M16x1.5			
200										

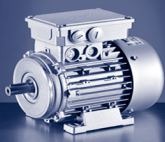

## Accessories

### Motor connection

#### Motor terminal box with ICN connector

The connectors can be rotated through 270° and fitted with a bayonet fixing. As the connector fixing is also compatible with conventional union nuts, existing mating connectors can continue to be used without difficulty. The motor connection is determined in the terminal box and must be checked before commissioning.

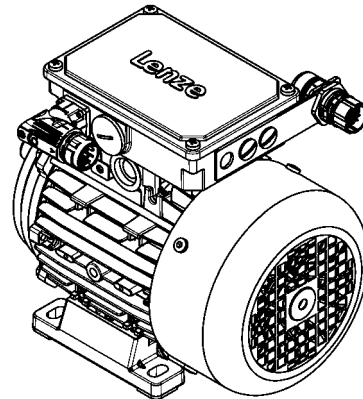

Design			ICN 6-pole	ICN 8-pole
Number of power contacts			3	
Number of earthing contacts			1	
Number of signalling contacts			2	
Brake/rectifier supply voltage				2
TCO thermal contacts supply voltage				
Max. current	$I_{max}$	[A]	20.0	
Socket identifier for Lenze system cables			M04	M6
Counter plug				



### Motor terminal box with HAN-10 E connector

In the case of the rectangular HAN-10E plug-in connectors, all six ends of the three winding phases are taken out to the power contacts. The motor circuit is therefore determined in the mating connector.

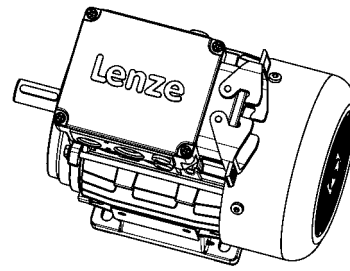

<b>Design</b>			<b>HAN-10E</b>
<b>Number of power contacts</b>			6
<b>Number of earthing contacts</b>			1
<b>Number of signalling contacts</b>			2
Brake/rectifier supply voltage			2
TCO thermal contacts supply voltage			2
<b>Max. current</b>	$I_{max}$	[A]	16.0
<b>Socket identifier for Lenze system cables</b>			H07 ... H09
Counter plug			

### Motor terminal box with HAN modular connector

The connector is available with two different power modules (16 A or 40 A), depending on the rated motor current. The motor connection is determined in the terminal box and must be checked before commissioning.

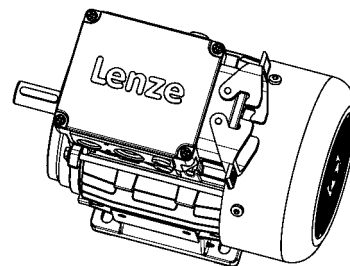

<b>Design</b>			<b>HAN modular</b>
<b>Number of power contacts</b>			3
<b>Number of earthing contacts</b>			1
<b>Number of signalling contacts</b>			2
Brake/rectifier supply voltage			2
Rectifier DC switching contacts supply voltage			2
TCO thermal contacts supply voltage			2
<b>Max. current</b>	$I_{max}$	[A]	16.0 40.0
<b>Socket identifier for Lenze system cables</b>			H07 ... H09
Counter plug			

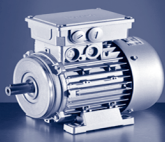

### Connector for feedback

#### ICN connector

All encoder systems (apart from IG128-24V-H) are also available with an ICN connector fixed to the motor terminal box for exceptionally fast commissioning. The connectors are fitted with a bayonet fixing, which is also compatible with conventional union nuts. Existing mating connectors can therefore continue to be used without difficulty.

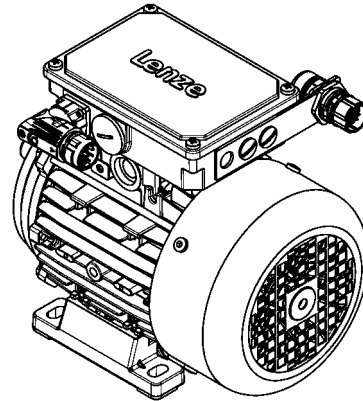

Design		Resolver	Incremental encoder SinCos absolute value encoder
Number of signalling contacts			12
Coding	[°]	0	20
Socket identifier for Lenze system cables Counter plug		F05	F06

#### Connector for IG128-24V-H

As a standard this incremental encoder is equipped with a connection cable of about 0.5 m length and with a common industry standard M12 connector at its end.

Design		Incremental encoder IG128-24V-H
Number of signalling contacts		4
Coding	[°]	0



### ICN connector for blower

The blower is also optionally available with an ICN connector fixed to the terminal box of the blower for exceptionally fast commissioning. The connectors are fitted with a bayonet fixing, which is also compatible with conventional union nuts. Existing counter plugs can therefore continue to be used without difficulty.

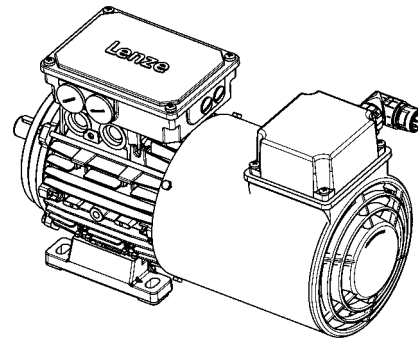

Design	Blower 1-ph	Blower 3-ph
Number of power contacts		6
Number of earthing contacts		1
Socket identifier for Lenze system cables		
Counter plug	L04	L06



## Accessories

### Motor connection

#### Assignment: Motor – decentralised frequency inverters 8200 motec

Rated frequency 50 Hz

Rated power	Product key		
	Motor	Inverter	
$P_N$ [kW]			
0.12	MD□MA□□063-12	E82MV251_2B	
0.18	MD□MA□□063-32		
0.25	MD□MA□□063-42		
	MD□MA□□071-12		
0.37	MD□MA□□071-32	E82MV371_2B	
0.55	MD□MA□□071-42	E82MV551_4B	
	MD□MA□□080-12		
0.75	MD□MA□□080-32	MH□MA□□080-32	E82MV751_4B
1.10	MD□MA□□080-42	MH□MA□□090-12	E82MV152_4B
	MD□MA□□090-12		
1.50	MD□MA□□090-32	MH□MA□□090-32	
2.20	MD□MA□□100-12	MH□MA□□100-12	E82MV222_4B
3.00	MD□MA□□100-32	MH□MA□□100-32	E82MV302_4B
4.00	MD□MA□□112-22	MH□MA□□112-22	E82MV402_4B
5.50	MD□MA□□132-12	MH□MA□□132-12	E82MV552_4B
7.50	MD□MA□□132-22	MH□MA□□132-22	E82MV752_4B

Rated frequency 87 Hz

Rated power	Product key		
	Motor	Inverter	
$P_N$ [kW]			
0.21	MD□MA□□063-12	E82MV551_4B	
0.33	MD□MA□□063-32		
0.45	MD□MA□□063-42		
	MD□MA□□071-12		
0.66	MD□MA□□071-32	E82MV751_4B	
1.00	MD□MA□□071-42	E82MV152_4B	
	MD□MA□□080-12		
1.35	MD□MA□□080-32	MH□MA□□080-32	
2.00	MD□MA□□080-42	MH□MA□□090-12	E82MV222_4B
	MD□MA□□090-12		
2.70	MD□MA□□090-32	MH□MA□□090-32	E82MV302_4B
3.90	MD□MA□□100-12	MH□MA□□100-12	E82MV402_4B
5.40	MD□MA□□100-32	MH□MA□□100-32	E82MV552_4B
7.10	MD□MA□□112-22	MH□MA□□112-22	E82MV752_4B



### Features and assignments

Three-phase AC motors can be fitted with a spring-applied brake. This is activated after the supply voltage is switched off (closed-circuit principle). For optimum adjustment of the brake motor to the application, a range of braking torques and control versions is available for every motor frame size. For applications with very high operating frequencies the brake is also available in a LongLife version, with reinforced mechanical brake components.

### Features

#### Versions

##### ► Standard

1 x 10<sup>6</sup> Repeating switching cycles

1 x 10<sup>6</sup> Reversing switching cycles

##### ► LongLife

10 x 10<sup>6</sup> Repeating switching cycles

15 x 10<sup>6</sup> Reversing switching cycles

#### Control

► DC supply

► AC supply via rectifier in the terminal box

#### Enclosure

► Without manual release IP55

► With manual release IP54

#### Friction lining

► Non-asbestos, low wearing

#### Options

► Manual release

► UL/CSA approval

► Noise-reduced

### Motor – brake assignment

Type	Standard		LongLife	
	Size	Rated torque	Size	Rated torque
	Brake		Brake	
		$M_k$		$M_k$
		[Nm]		[Nm]
MD□MA□□063-12 MD□MA□□063-32 MD□MA□□063-42	06	2.50	06	4.00
	06	4.00		
	06	4.00		
MD□MA□□071-12 MD□MA□□071-32	06	2.50	06	4.00
	06	4.00		
	08	3.50		
MD□MA□□071-42	06	2.50	06	4.00
	06	4.00		
	08	3.50		
	08	8.00		
MD□MA□□080-12 MD□MA□□080-32 MH□MA□□080-32	08	3.50	08	8.00
	08	8.00		
	10	7.00		
MD□MA□□080-42	08	3.50	08	8.00
	08	8.00		
	10	7.00		
	10	16.0		

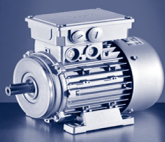

## Accessories

### Spring-applied brake

Type	Standard		LongLife	
	Size	Rated torque	Size	Rated torque
	Brake		Brake	
		$M_k$ [Nm]		$M_k$ [Nm]
MD□MA□□090-12 MD□MA□□090-32 MH□MA□□090-12 MH□MA□□090-32	08	3.50	08 10 10	8.00 7.00 16.0
	08	8.00		
	10	7.00		
	10	16.0		
	10	23.0		
MD□MA□□100-12 MH□MA□□100-12	10	7.00	10 12 12	16.0 14.0 32.0
	10	16.0		
	12	14.0		
MD□MA□□100-32 MH□MA□□100-32	12	32.0		
	10	7.00		
	10	16.0		
	12	14.0		
	12	32.0		
MD□MA□□112-22 MH□MA□□112-22	12	46.0		
	12	14.0		
	14	35.0		
MD□MA□□132-12 MD□MA□□132-22 MH□MA□□132-12 MH□MA□□132-22	14	60.0		
	14	35.0		
	14	60.0		
	16	60.0		
	16	80.0		
MD□MA□□160-22 MH□MA□□160-22	16	100		
	16	60.0		
	18	80.0		
MD□MA□□160-32 MH□MA□□160-32	18	80.0		
	18	80.0		
	18	150		
MD□MA□□180-12 MH□MA□□180-12	18	200		
	18	80.0		
	18	150		
MD□MA□□180-32 MH□MA□□180-32	20	145		
	20	260		
	20	80.0		
	20	150		
	20	145		
MH□MA□□200-22	20	260		
	20	315		
	20	80.0		
	20	150		
	20	145		
	20	260		
	20	315		
	20	400		



### Brake connection

#### Direct connection without rectifier

If the brake is activated directly without a rectifier, a freewheeling diode or a spark suppressor is required to protect against induction peaks.

- ▶ Supply voltages
  - DC 24 V
  - DC 180 V
  - DC 205 V

#### Connection via mains voltage with brake rectifier

If the brake is not directly supplied with DC voltage, a rectifier is required. This is included in the scope of supply and is located in the terminal box of the motor. The rectifier converts the AC voltage of the connection into DC voltage. The following rectifiers are available:

##### Half-wave rectifier, 6-pin

- ▶ Ratio of supply voltage to brake coil voltage = 2.22
- ▶ Approved by UL/CSA
- ▶ Supply voltages
  - AC 230 V
  - AC 277 V
  - AC 400 V
  - AC 460 V
  - AC 480 V

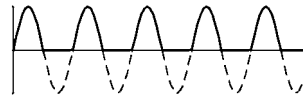

##### Bridge rectifier, 6-pole

- ▶ Ratio of supply voltage to brake coil voltage = 1.11
- ▶ Supply voltage
  - AC 230 V



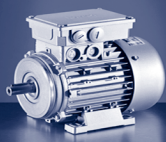

## Accessories

### Spring-applied brake

#### Bridge/half-wave rectifier, 6-pole

- ▶ Ratio of supply voltage to brake coil voltage up to overexcitation time = 1.11  
beyond overexcitation time = 2.22

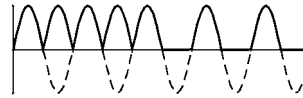

#### Supply voltages:

- ▶ AC 230 V
- ▶ AC 277 V
- ▶ AC 400 V

During the switching operation the bridge/half-wave rectifier functions as a bridge rectifier for the overexcitation time  $t_{oe}$  and then as a half-wave rectifier. This combination optimises the properties of the brake – depending on the assignment of brake coil voltage and supply voltage:

#### ▶ Short-time overexcitation of the brake coil

Activating the brake coil for the overexcitation time  $t_{ü}$  with twice the rated voltage allows the disengagement time to be reduced. The brake opens more quickly and wear on the friction lining is reduced.

These features make this activation version particularly suitable for lifting applications. It is therefore only available in combination with a brake with increased braking torque.

#### ▶ Holding current reduction (cold brake)

By reducing the holding current, the bridge/half-wave rectifier is able to reduce the power input of the open brake. As the brake heats up less, this type of activation is known as "cold brake".



Permissible friction energy

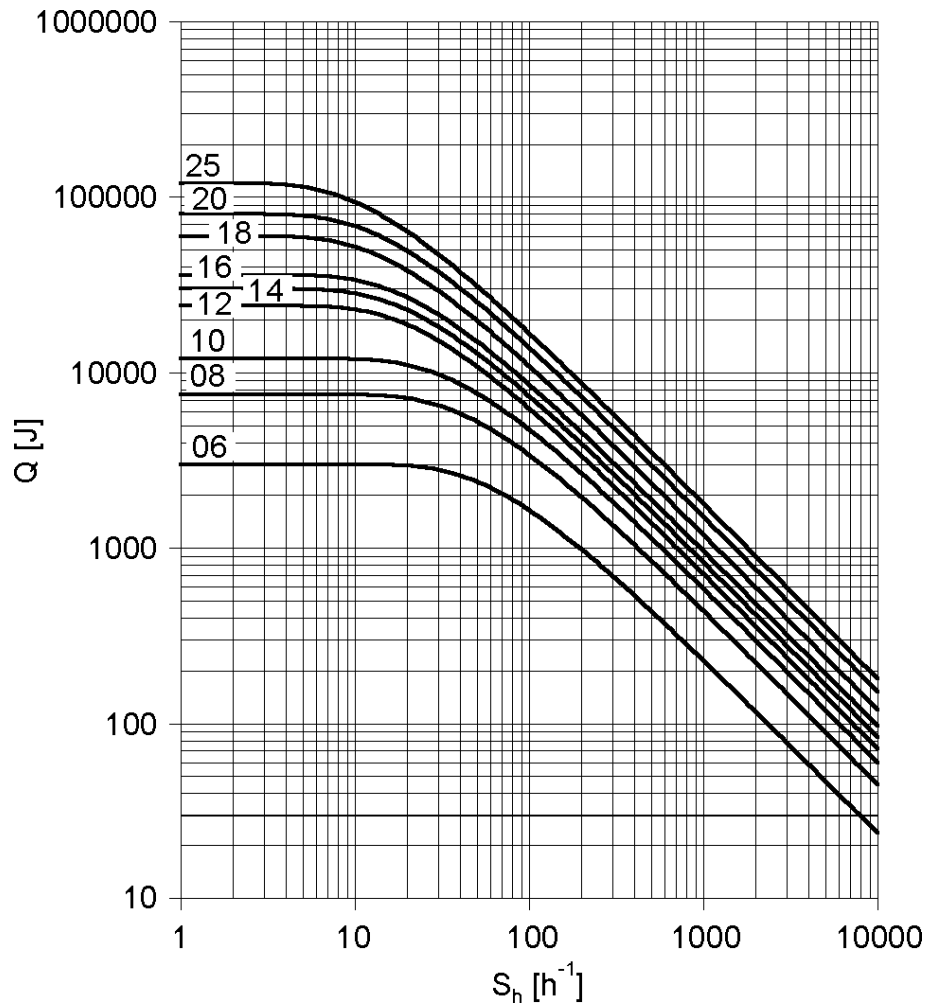

Q = Switching energy per switching cycle  
 $S_h$  = Operating frequency  
 Brake size = 06 ... 25



## Accessories

### Spring-applied brake

#### Brake data, reduced braking torque

- Please enquire for braking torques and maximum switching work values not listed here.

Size			06	08	10	12	14	16	18	20	25
<b>Coil power</b>	P	[kW]	0.020	0.025	0.030	0.040	0.050	0.055	0.085	0.10	0.11
<b>Braking torque</b>											
100	M <sub>B</sub>	[Nm]	2.50	3.50	7.00	14.0	35.0	60.0	80.0	145	265
1000	M <sub>B</sub>	[Nm]	2.30	3.10	6.10	12.0	30.0	50.0	65.0	115	203
1200	M <sub>B</sub>	[Nm]	2.30	3.10	6.00	12.0	29.0	48.0	63.0	112	199
1500	M <sub>B</sub>	[Nm]	2.20	3.00	5.80	11.0	28.0	47.0	61.0	109 <sup>1)</sup>	193 <sup>1)</sup>
1800	M <sub>B</sub>	[Nm]	2.10	2.90	5.70	11.0	28.0	46.0	60.0 <sup>1)</sup>		
3000	M <sub>B</sub>	[Nm]	2.00	2.80	5.30	10.0	26.0 <sup>1)</sup>	43.0 <sup>1)</sup>			
3600	M <sub>B</sub>	[Nm]	2.00	2.70	5.20	10.0 <sup>1)</sup>					
<b>Maximum switching energy</b>											
100	Q <sub>E</sub>	[J]	3.00	7.50	12.0	24.0	30.0	36.0	60.0	80.0	120
1000	Q <sub>E</sub>	[J]	3.00	7.50	12.0	24.0	30.0	36.0	60.0	80.0	120
1200	Q <sub>E</sub>	[J]	3.00	7.50	12.0	24.0	30.0	36.0	60.0	80.0	120
1500	Q <sub>E</sub>	[J]	3.00	7.50	12.0	24.0	30.0	36.0	60.0	24.0 <sup>1)</sup>	36.0 <sup>1)</sup>
1800	Q <sub>E</sub>	[J]	3.00	7.50	12.0	24.0	30.0	36.0	36.0 <sup>1)</sup>		
3000	Q <sub>E</sub>	[J]	3.00	7.50	12.0	24.0	18.0 <sup>1)</sup>	11.0 <sup>1)</sup>			
3600	Q <sub>E</sub>	[J]	3.00	7.50	12.0	7.00 <sup>1)</sup>					
<b>Transition operating frequency</b>	S <sub>hü</sub>	[1/h]	79.0	50.0	40.0	30.0	28.0	27.0	20.0	19.0	15.0
<b>Moment of inertia</b>	J	[kgcm <sup>2</sup> ]	0.015	0.061	0.20	0.45	0.63	1.50	2.90	7.30	20.0
<b>Mass</b>	m	[kg]	0.90	1.50	2.60	4.20	5.80	8.70	12.6	19.5	31.0

<sup>1)</sup> In the region of the load limit the value for Q<sub>BW</sub> can be reduced to 40 %.



### Activation via half-wave or bridge rectifier

Size			06	08	10	12	14	16	18	20	25
Friction energy	$Q_{BW}$	[MJ]	113	210	264	706	761	966	1542	2322	3522
Delay time Engaging	$t_{11}$	[ms]	11.0	14.0	20.0	21.0	37.0	53.0	32.0	47.0	264
Rise time Braking torque	$t_{12}$	[ms]	13.0	10.0	17.0	19.0	22.0	30.0	20.0	100	120
Engagement time	$t_1$	[ms]	24.0		37.0	40.0	59.0	83.0	52.0	147	384
Disengagement time	$t_2$	[ms]	35.0	37.0	57.0	65.0	148	169	230	207	269

### Activation via bridge/half-wave rectifier

Design			Holding current reduction (cold brake)								
Size			06	08	10	12	14	16	18	20	25
Friction energy	$Q_{BW}$	[MJ]	113	210	264	706	761	966	1542	2322	3522
Overexcitation time	$t_{\ddot{u}}$	[ms]	300				1300				
Min. rest time	$t$	[ms]	900				3900				
Delay time Engaging	$t_{11}$	[ms]	12.0	22.0	35.0	49.0	61.0	114	83.0	126	304
Rise time Braking torque	$t_{12}$	[ms]	14.0	16.0	30.0	45.0	37.0	65.0	52.0	269	138
Engagement time	$t_1$	[ms]	26.0	38.0	66.0	93.0	97.0	180	134	395	443
Disengagement time	$t_2$	[ms]	35.0	37.0	57.0	65.0	148	169	230	207	269

- ▶ The brake response and application times are guide values.  
The engagement time is 10 times longer with AC-side switching.  
With the maximum air gap the disengagement time  $t_2$  – depending on the brake and control – is up to 4 times longer than the disengagement time with the rated air gap.



## Accessories

### Spring-applied brake

#### Brake data, standard braking torque

- Please enquire for braking torques and maximum switching work values not listed here.

Size			06	08	10	12	14	16	18	20	25
<b>Coil power</b>	P	[kW]	0.020	0.025	0.030	0.040	0.050	0.055	0.085	0.10	0.11
<b>Braking torque</b>											
100	M <sub>B</sub>	[Nm]	4.00	8.00	16.0	32.0	60.0	80.0	150	260	400
1000	M <sub>B</sub>	[Nm]	3.70	7.20	14.0	27.0	51.0	66.0	121	206	307
1200	M <sub>B</sub>	[Nm]	3.60	7.00	14.0	27.0	50.0	65.0	118	201	300
1500	M <sub>B</sub>	[Nm]	3.50	6.80	13.0	26.0	48.0	63.0	115	195 <sup>1)</sup>	291 <sup>1)</sup>
1800	M <sub>B</sub>	[Nm]	3.40	6.70	13.0	26.0	47.0	61.0	112 <sup>1)</sup>		
3000	M <sub>B</sub>	[Nm]	3.20	6.30	12.0	24.0	44.0 <sup>1)</sup>	57.0 <sup>1)</sup>			
3600	M <sub>B</sub>	[Nm]	3.20	6.10	12.0	23.0 <sup>1)</sup>					
<b>Maximum switching energy</b>											
100	Q <sub>E</sub>	[J]	3.00	7.50	12.0	24.0	30.0	36.0	60.0	80.0	120
1000	Q <sub>E</sub>	[J]	3.00	7.50	12.0	24.0	30.0	36.0	60.0	80.0	120
1200	Q <sub>E</sub>	[J]	3.00	7.50	12.0	24.0	30.0	36.0	60.0	80.0	120
1500	Q <sub>E</sub>	[J]	3.00	7.50	12.0	24.0	30.0	36.0	60.0	24.0 <sup>1)</sup>	36.0 <sup>1)</sup>
1800	Q <sub>E</sub>	[J]	3.00	7.50	12.0	24.0	30.0	36.0	36.0 <sup>1)</sup>		
3000	Q <sub>E</sub>	[J]	3.00	7.50	12.0	24.0	18.0 <sup>1)</sup>	11.0 <sup>1)</sup>			
3600	Q <sub>E</sub>	[J]	3.00	7.50	12.0	7.00 <sup>1)</sup>					
<b>Transition operating frequency</b>	S <sub>hü</sub>	[1/h]	79.0	50.0	40.0	30.0	28.0	27.0	20.0	19.0	15.0
<b>Moment of inertia</b>	J	[kgcm <sup>2</sup> ]	0.015	0.061	0.20	0.45	0.63	1.50	2.90	7.30	20.0
<b>Mass</b>	m	[kg]	0.90	1.50	2.60	4.20	5.80	8.70	12.6	19.5	31.0

<sup>1)</sup> In the region of the load limit the value for Q<sub>BW</sub> can be reduced to 40 %.



### Activation via half-wave or bridge rectifier

Size			06	08	10	12	14	16	18	20	25
Friction energy	$Q_{BW}$	[MJ]	85.0	158	264	530	571	966	1542	2322	3522
Delay time Engaging	$t_{11}$	[ms]	15.0		28.0		17.0	27.0	33.0	65.0	110
Rise time Braking torque	$t_{12}$	[ms]	13.0	16.0	19.0	25.0		30.0	45.0	100	120
Engagement time	$t_1$	[ms]	28.0	31.0	47.0	53.0	42.0	57.0	78.0	165	230
Disengagement time	$t_2$	[ms]	45.0	57.0	76.0	115	210	220	270	340	390

### Activation via bridge/half-wave rectifier

Design			Holding current reduction (cold brake)								
Size			06	08	10	12	14	16	18	20	25
Friction energy	$Q_{BW}$	[MJ]	85.0	158	264	530	571	966	1542	2322	3522
Overexcitation time	$t_{\ddot{u}}$	[ms]	300				1300				
Min. rest time	$t$	[ms]	900				3900				
Delay time Engaging	$t_{11}$	[ms]	16.0	25.0	31.0	48.0	33.0	58.0	80.0	102	154
Rise time Braking torque	$t_{12}$	[ms]	14.0	27.0	21.0	43.0	49.0	64.0	109	157	168
Engagement time	$t_1$	[ms]	30.0	52.0		90.0	82.0	122	189	259	322
Disengagement time	$t_2$	[ms]	45.0	57.0	76.0	115	210	220	270	340	390

- ▶ The brake response and application times are guide values.  
The engagement time is 10 times longer with AC-side switching.  
With the maximum air gap the disengagement time  $t_2$  – depending on the brake and control – is up to 4 times longer than the disengagement time with the rated air gap.

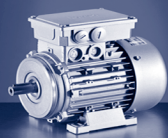

## Accessories

### Spring-applied brake

#### Brake data, increased braking torque

- Please enquire for braking torques and maximum switching work values not listed here.

Size			10	12	14	16	16	18	20	20	25	25
<b>Coil power</b>	P	[kW]	0.030	0.040	0.050	0.055	0.055	0.085	0.10	0.10	0.11	0.11
<b>Braking torque</b>												
100	M <sub>B</sub>	[Nm]	23.0	46.0	75.0	100	125	200	315	400	490	600
1000	M <sub>B</sub>	[Nm]	20.0	39.0	64.0	83.0	103	162	249	317	376	461
1200	M <sub>B</sub>	[Nm]	20.0	39.0	62.0	81.0	101	158	244	309	367	449
1500	M <sub>B</sub>	[Nm]	19.0	38.0	60.0	78.0	98.0	153	237 <sup>1)</sup>	300 <sup>1)</sup>	356 <sup>1)</sup>	436 <sup>1)</sup>
1800	M <sub>B</sub>	[Nm]	19.0	37.0	59.0	77.0	96.0	150 <sup>1)</sup>				
3000	M <sub>B</sub>	[Nm]	17.0	34.0	55.0 <sup>1)</sup>	71.0 <sup>1)</sup>	89.0 <sup>1)</sup>					
3600	M <sub>B</sub>	[Nm]	17.0	33.0 <sup>1)</sup>								
<b>Maximum switching energy</b>												
100	Q <sub>E</sub>	[J]	12.0	24.0	30.0	36.0	36.0	60.0	80.0	80.0	120	120
1000	Q <sub>E</sub>	[J]	12.0	24.0	30.0	36.0	36.0	60.0	80.0	80.0	120	120
1200	Q <sub>E</sub>	[J]	12.0	24.0	30.0	36.0	36.0	60.0	80.0	80.0	120	120
1500	Q <sub>E</sub>	[J]	12.0	24.0	30.0	36.0	36.0	60.0	24.0 <sup>1)</sup>	24.0 <sup>1)</sup>	36.0 <sup>1)</sup>	36.0 <sup>1)</sup>
1800	Q <sub>E</sub>	[J]	12.0	24.0	30.0	36.0	36.0	36.0 <sup>1)</sup>				
3000	Q <sub>E</sub>	[J]	12.0	24.0	18.0 <sup>1)</sup>	11.0 <sup>1)</sup>	11.0 <sup>1)</sup>					
3600	Q <sub>E</sub>	[J]	12.0	7.00 <sup>1)</sup>								
<b>Transition operating frequency</b>	S <sub>hü</sub>	[1/h]	40.0	30.0	28.0	27.0	27.0	20.0	19.0	19.0	15.0	15.0
<b>Moment of inertia</b>	J	[kgcm <sup>2</sup> ]	0.20	0.45	0.63	1.50	1.50	2.90	7.30	7.30	20.0	20.0
<b>Mass</b>	m	[kg]	2.60	4.20	5.80	8.70	8.70	12.6	19.5	19.5	31.0	31.0

<sup>1)</sup> In the region of the load limit the value for Q<sub>BW</sub> can be reduced to 40 %.

#### Activation via half-wave or bridge rectifier

Size			10	12	14	16	18	20	20	25	25	
<b>Friction energy</b>	Q <sub>BW</sub>	[MJ]	198	353	253	563	241	578	1596	580	2465	1409
<b>Delay time</b>												
Engaging	t <sub>11</sub>	[ms]	10.0	16.0	11.0	22.0	17.0	24.0	46.0	17.0	77.0	38.0
<b>Rise time</b>												
Braking torque	t <sub>12</sub>	[ms]	19.0	25.0		30.0	45.0		100		120	
<b>Engagement time</b>	t <sub>1</sub>	[ms]	29.0	41.0	36.0	52.0	47.0	69.0	146	117	197	158
<b>Disengagement time</b>	t <sub>2</sub>	[ms]	109	193	308	297	435	356	378	470	451	532



### Activation via bridge/half-wave rectifier

Design			Holding current reduction (cold brake)									
Size			10	12	14	16	18	20	25			
Friction energy	$Q_{BW}$	[MJ]	198	353	253	563	241	578	1596	580	2465	1409
Overexcitation time	$t_{\ddot{u}}$	[ms]	300					1300				
Min. rest time	$t$	[ms]	900					3900				
Delay time												
Engaging	$t_{11}$	[ms]	24.0	27.0	17.0	41.0	21.0	60.0	69.0	17.0	123	85.0
Rise time												
Braking torque	$t_{12}$	[ms]	44.0	43.0	37.0	55.0	37.0	113	148	100	190	270
Engagement time	$t_1$	[ms]	68.0	70.0	54.0	97.0	57.0	173	217	334	313	355
Disengagement time	$t_2$	[ms]	109	193	308	297	435	356	378	470	451	532

Design			Over-excitation									
Size			10	12	14	16	18	20	25			
Friction energy	$Q_{BW}$	[MJ]	264	706	761	966	1542	2322	3522			
Overexcitation time	$t_{\ddot{u}}$	[ms]	300					1300				
Min. rest time	$t$	[ms]	900					3900				
Delay time												
Engaging	$t_{11}$	[ms]	29.0	54.0	31.0	70.0	46.0	86.0	103	55.0	171	135
Rise time												
Braking torque	$t_{12}$	[ms]	53.0	87.0	68.0	93.0	83.0	160	222	319	266	430
Engagement time	$t_1$	[ms]	82.0	141	99.0	163	129	246	325	374	437	565
Disengagement time	$t_2$	[ms]	53.0	81.0	117	141	168	151	160	167	184	204

- ▶ The brake response and application times are guide values. The engagement time is 10 times longer with AC-side switching. With the maximum air gap the disengagement time  $t_2$  – depending on the brake and control – is up to 4 times longer than the disengagement time with the rated air gap.

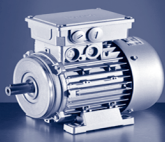

## Accessories

### Blower

- The terminal box for the separate fan is available in positions 2, 3 and 5.

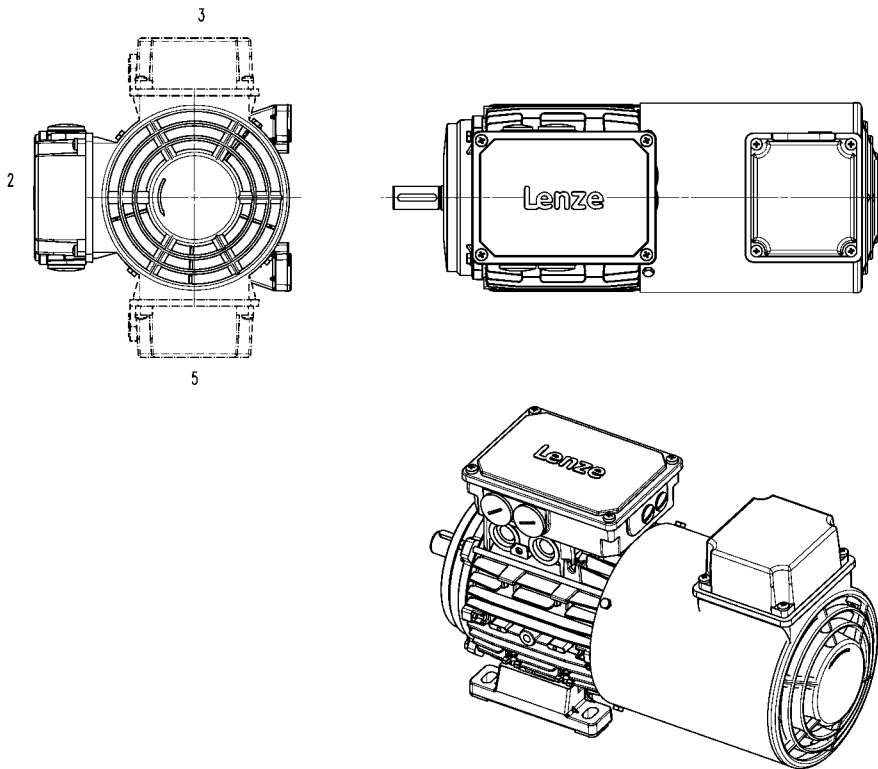

### Blower data 50 Hz

	Number of phases	Connection method	$U_{\min}$	$U_{\max}$	$P_{\max}$	$I_{\max}$	$m$
			[V]	[V]	[kW]	[A]	[kg]
063	1		230	277	0.027	0.10	2.00
	3	$\Delta$	220	290	0.029	0.050	
071	1		230	277		0.028	0.10
	3	$\Delta$	220	290	0.030	0.050	
080	1		230	277		0.029	0.11
	3	$\Delta$	220	290	0.031	0.10	
090	1		230	277		0.082	0.30
	3	$\Delta$	220	290	0.097	0.34	
100	1		230	277		0.086	0.31
	3	$\Delta$	220	290	0.10	0.35	
112	1		230	277		0.085	0.31
	3	$\Delta$	220	290	0.095	0.33	
			380	500			0.18



	Number of phases	Connection method	$U_{min}$	$U_{max}$	$P_{max}$	$I_{max}$	$m$
			[V]	[V]	[kW]	[A]	[kg]
132	1		230	277	0.12	0.40	4.20
	3	$\Delta$	220	290	0.14	0.45	
		Y	380	500		0.24	
160	1		230	277	0.24	0.96	6.20
	3	$\Delta$	220	290	0.22	0.76	
		Y	380	500		0.43	
180	1		230	277	0.24	0.96	8.00
	3	$\Delta$	220	290	0.22	0.76	
		Y	380	500		0.43	
200	1		230	277	0.24	0.96	8.00
	3	$\Delta$	220	290	0.22	0.76	
		Y	380	500		0.43	

### Blower data 60 Hz

	Number of phases	Connection method	$U_{min}$	$U_{max}$	$P_{max}$	$I_{max}$	$m$
			[V]	[V]	[kW]	[A]	[kg]
063	1		230	277	0.038	0.11	2.00
	3	$\Delta$	220	332	0.032		
		Y	380	575		0.060	
071	1		230	277	0.041	0.12	2.10
	3	$\Delta$	220	332	0.033	0.10	
		Y	380	575		0.060	
080	1		230	277	0.044	0.13	2.30
	3	$\Delta$	220	332	0.034	0.10	
		Y	380	575		0.060	
090	1		220	277	0.070	0.25	2.70
	3	$\Delta$	220	332	0.10	0.30	
		Y	380	575		0.18	
100	1		220	277	0.079	0.29	3.00
	3	$\Delta$	220	332	0.10	0.32	
		Y	380	575		0.18	
112	1		220	277	0.095	0.39	3.10
	3	$\Delta$	220	332	0.10	0.31	
		Y	380	575		0.18	
132	1		230	277	0.18	0.59	4.20
	3	$\Delta$	220	332	0.15	0.41	
		Y	380	575		0.24	
160	3	$\Delta$	220	332	0.28	0.94	6.20
		Y	380	575		0.56	
180	3	$\Delta$	220	332	0.28	0.94	8.00
		Y	380	575		0.56	
200	3	$\Delta$	220	332	0.28	0.94	8.00
		Y	380	575		0.56	

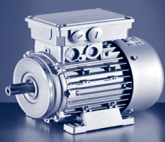

## Accessories

### Feedback

Tailored to meet the requirements of the various applications and necessary accuracies, the following feedback systems are available.

### Resolver

Stator-fed resolver with two stator windings offset by 90° and one rotor winding with transformer winding.

<b>Accuracy</b>			[°]	<b>-10 ... 10</b>
<b>Absolute positioning</b>				1 revolution
<b>Max. input voltage</b> DC	$U_{in,max}$		[V]	10.0
<b>Max. input frequency</b>	$f_{in,max}$		[kHz]	4.00
<b>Ratio</b> Stator / rotor		± 5 %		0.30
<b>Rotor impedance</b>	$Z_{ro}$		[Ω]	51 + j90
<b>Stator impedance</b>	$Z_{so}$		[Ω]	102 + j150
<b>Impedance</b>	$Z_{rs}$		[Ω]	44 + j76
<b>Min. insulation resistance</b> At DC 500 V	<b>R</b>		[MΩ]	10.0
<b>Number of pole pairs</b>				1



## Incremental encoder and SinCos absolute value encoder

Encoder type			HTL incremental				TTL incremental			SinCos absolute value			
Product key			IG128-24V-H	IG512-24V-H	IG1024-24V-H	IG2048-24V-H	IG512-5V-T	IG1024-5V-T	IG2048-5V-T	AS1024-8V-H	AM1024-8V-H		
Encoder type												Single-turn	Multi-turn
Pulses			128	512	1024	2048	512	1024	2048	1024			
Output signals			HTL				TTL			1 V <sub>ss</sub>			
Interfaces												Hiperface	
Absolute revolutions			0							1	4096		
Accuracy		[°]	-22.5 ... 22.5		-2 ... 2				-0.8 ... 0.8				
Min. input voltage DC	$U_{in,min}$	[V]	8.00				5.00			7.00			
Max. input voltage DC	$U_{in,max}$	[V]	26.0	30.0			5.25			12.0			
Max. current consumption	$I_{max}$	[A]	0.040	0.15				0.080					
Limit frequency	$f_{max}$	[kHz]	30.0	160			300			200			

- ▶ Motor frame sizes 063 ... 132: The absolute value encoders AS1024-8V-H and AM1024-8V-H are currently only available in combination with a blower.

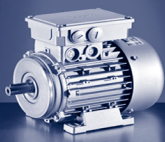

## Accessories

### Thermal sensor

The thermal sensors are integrated in the windings. The use of an additional motor protection switch is recommended.

### Thermal contacts

Function	Operating temperature	Min. reset temperature	Max. reset temperature	Max. input current	Max. input voltage
					AC
	T	T <sub>min</sub>	T <sub>max</sub>	I <sub>in,max</sub>	U <sub>in,max</sub>
	-5 ... 5				
	[°C]	[°C]	[°C]	[A]	[V]
NC contact	150	90.0	135	2.50	250

### PTC thermistor

Function	Operating temperature	Rated resistance			Standard
		155 °C	-20 °C	140 °C	
	T	R <sub>N</sub>	R <sub>N</sub>	R <sub>N</sub>	
	-5 ... 5				
	[°C]	[Ω]	[Ω]	[Ω]	
Sudden change in resistance	150	550	30.0	250	DIN 44080 DIN VDE 0660 Part 303



### KTY continuous temperature sensor

	Function	Rated resistance			Max. input current	
		25 °C	150 °C	170 °C	25 °C	170 °C
		$R_N$	$R_N$	$R_N$	$I_{in,max}$	$I_{in,max}$
		[ $\Omega$ ]	[ $\Omega$ ]	[ $\Omega$ ]	[A]	[A]
<b>KTY83-110</b>	Continuous resistance change	1000	2225	2471	0.010	0.002
<b>KTY84-130</b>	Continuous resistance change	603	1334	1482	0.010	0.002

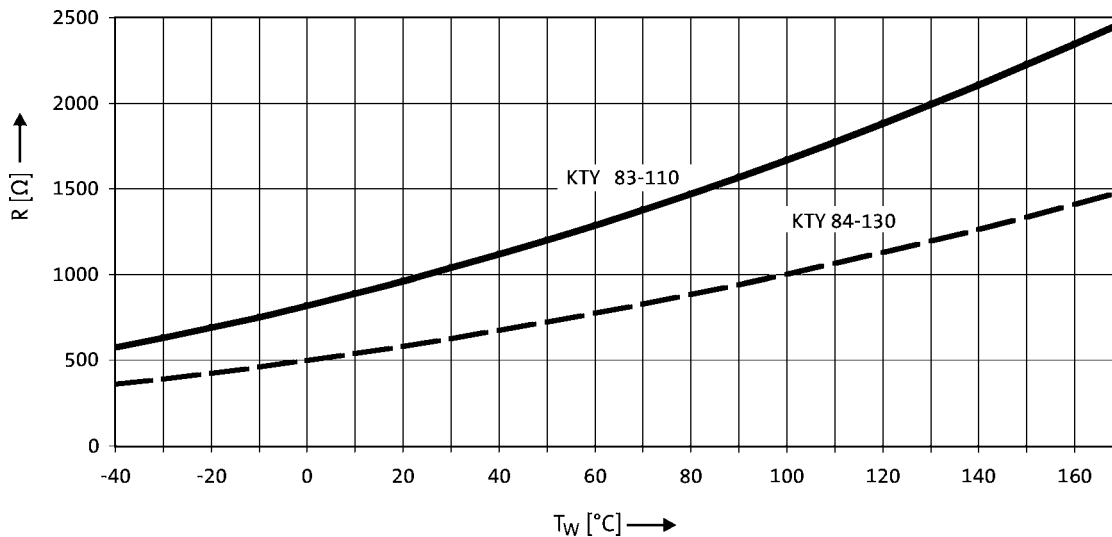

- ▶ If the detector is supplied with a measured current of 1 mA, the above relationship between the temperature and the resistance applies.

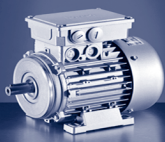

## Dimensions

### MDEMA, B3

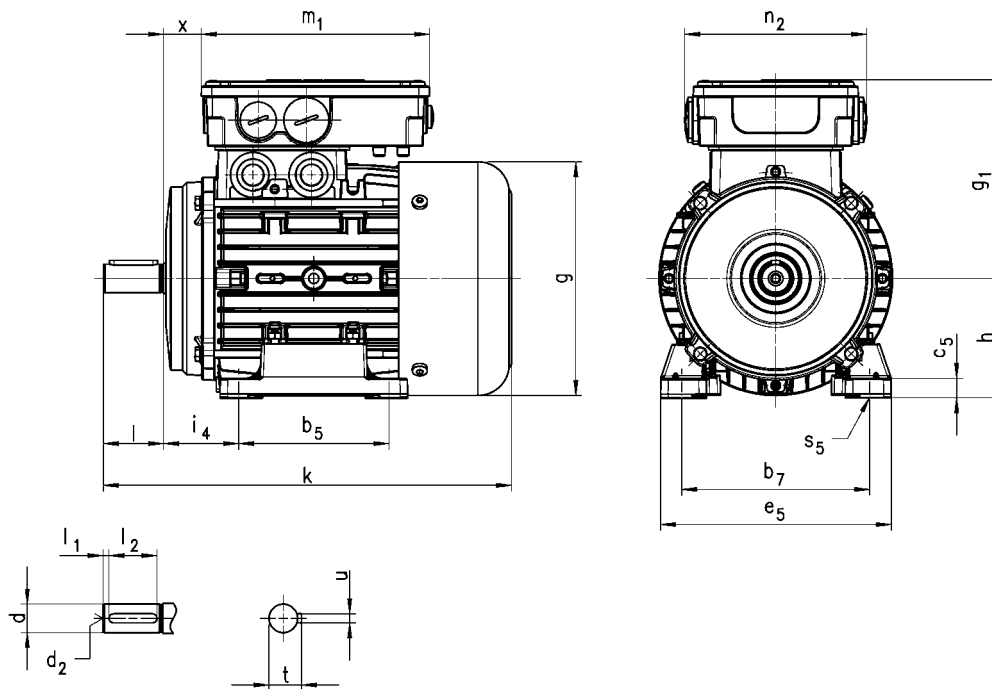

Motor type	MDEMAXX						MDEMABR					
	k	g	g <sub>1</sub>	x	m <sub>1</sub>	n <sub>2</sub>	k	g	g <sub>1</sub>	x	m <sub>1</sub>	n <sub>2</sub>
	[mm]	[mm]	[mm]	[mm]	[mm]	[mm]	[mm]	[mm]	[mm]	[mm]	[mm]	[mm]
<b>063</b>	215	123	109	17.0	136	103	255	123	109	17.0	136	103
<b>071</b>	246	139	118	23.5			297	139	118	23.5		
<b>080</b>	272	156	132	25.0	152	121	345	154	132	25.0	152	121
<b>090</b>	311	176	137	29.0			373	176	137	29.0		
<b>100</b>	382	194	147	36.0			458	194	147	36.0		
<b>112</b>	392	218	158	38.0	194	125	479	218	158	38.0	194	125
<b>132</b>	497	258	187	51.0			576	258	187	51.0		
<b>160</b>	642	310	210	65.0	226	127	747	313	210	65.0	226	127
<b>180</b>	669	348	230	79.0			784	351	230	79.0		

Motor type	MDEMARS MDEMAIG MDEMAAG						MDEMABS MDEMABI MDEMABA					
	k	g	g <sub>1</sub>	x	m <sub>1</sub>	n <sub>2</sub>	k	g	g <sub>1</sub>	x	m <sub>1</sub>	n <sub>2</sub>
	[mm]	[mm]	[mm]	[mm]	[mm]	[mm]	[mm]	[mm]	[mm]	[mm]	[mm]	[mm]
<b>063</b>	255	123	109	17.0	136	103	318	123	109	17.0	136	103
<b>071</b>	297	139	118	23.5			338	139	133	13.0		
<b>080</b>	369	158	132	25.0	152	121	379	156	142	24.0	194	125
<b>090</b>	392	178	137	29.0			410	176	147	28.0		
<b>100</b>	463	196	147	36.0			479	194	158	35.0		
<b>112</b>	472	220	158	38.0	194	125	509	218	168	37.0	194	125
<b>132</b>	599	261	187	51.0			621	258	187	51.0		
<b>160</b>	735	313	210	65.0	226	127	833	313	210	65.0	226	127
<b>180</b>	750	351	230	79.0			863	351	230	79.0		



	d	d	d <sub>2</sub>	l	l <sub>1</sub>	l <sub>2</sub>	t	u
	j6	k6						
	[mm]	[mm]	[mm]	[mm]	[mm]	[mm]	[mm]	[mm]
<b>063</b>	11		M4	23	3.5	16	12.5	4.0
<b>071</b>	14		M5	30	4.0	22	16.0	5.0
<b>080</b>	19		M6	40		32	21.5	6.0
<b>090</b>	24		M8	50	5.0	40	27.0	8.0
<b>100</b>	28		M10	60		50	31.0	
<b>112</b>			M12	80		70	41.0	10.0
<b>132</b>			38	M16		110	100	45.0
<b>160</b>			42			51.5		14.0
<b>180</b>			48					

	b <sub>7</sub>	i <sub>4</sub>	b <sub>5</sub>	e <sub>5</sub>	h	c <sub>5</sub>	s <sub>5</sub>
	[mm]	[mm]	[mm]	[mm]	[mm]	[mm]	[mm]
<b>063</b>	100	40	80	120	63	10.0	7.0
<b>071</b>	112	45	90	134	71	10.5	
<b>080</b>	125	50	100	154	80	13.0	10.0
<b>090</b>	140	56		174	90		
<b>100</b>	160	63	140	194	100	15.0	12.0
<b>112</b>	190	70		223	112	14.0	
<b>132</b>	216	89		178	260	132	
<b>160</b>	254	108	210 <sup>1)</sup>	305	160	22.0	14.5
			254 <sup>2)</sup>				
<b>180</b>	279	121	241 <sup>3)</sup>	350	180	23.0	
			279 <sup>4)</sup>				

<sup>1)</sup> 160-22

<sup>2)</sup> 160-32

<sup>3)</sup> 180-12

<sup>4)</sup> 180-32

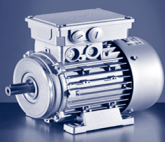

## Dimensions MDEMA, B5

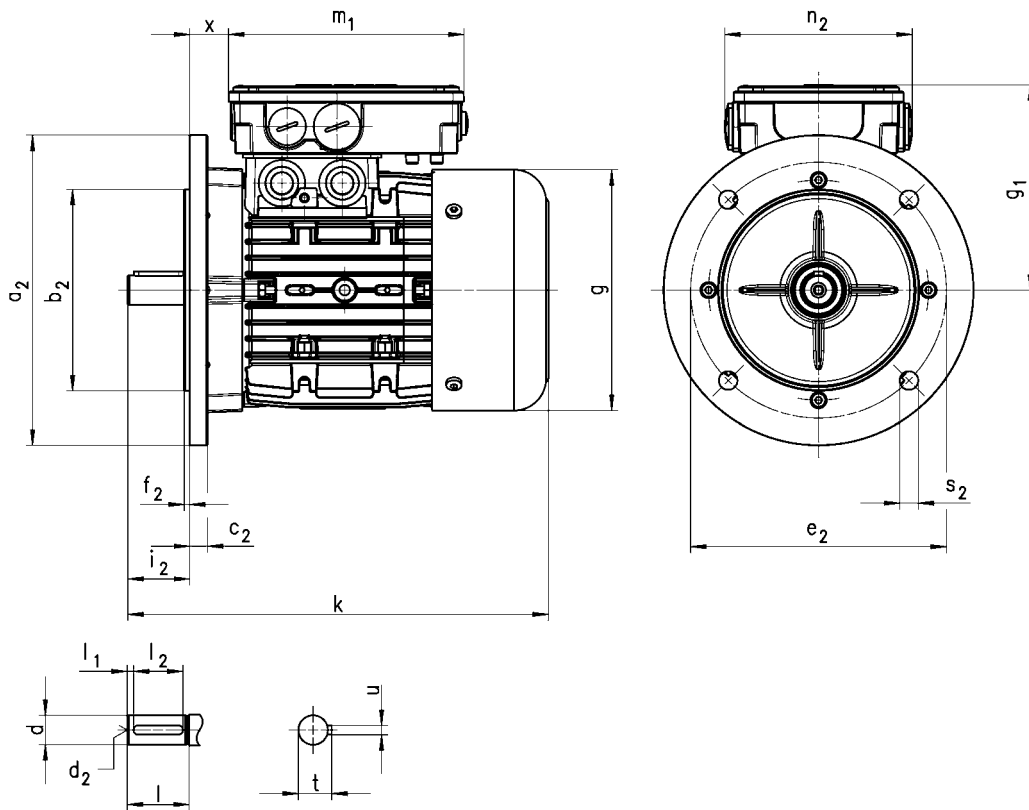

Motor type	MDEMAXX						MDEMABR					
	k	g	g <sub>1</sub>	x	m <sub>1</sub>	n <sub>2</sub>	k	g	g <sub>1</sub>	x	m <sub>1</sub>	n <sub>2</sub>
	[mm]	[mm]	[mm]	[mm]	[mm]	[mm]	[mm]	[mm]	[mm]	[mm]	[mm]	[mm]
<b>063</b>	215	123	109	17.0	136	103	255	123	109	17.0	136	103
<b>071</b>	246	139	118	23.5			297	139	118	23.5		
<b>080</b>	272	156	132	25.0	152	121	345	154	132	25.0	152	121
<b>090</b>	311	176	137	29.0			373	176	137	29.0		
<b>100</b>	382	194	147	36.0			458	194	147	36.0		
<b>112</b>	392	218	158	38.0			479	218	158	38.0		
<b>132</b>	497	258	187	51.0	194	125	576	258	187	51.0	194	125
<b>160</b>	642	310	210	65.0	226	127	747	313	210	65.0	226	127
<b>180</b>	669	348	230	79.0			784	351	230	79.0		



Motor type	MDEMARS MDEMAIG MDEMAAG						MDEMABS MDEMABI MDEMABA					
	k	g	g <sub>1</sub>	x	m <sub>1</sub>	n <sub>2</sub>	k	g	g <sub>1</sub>	x	m <sub>1</sub>	n <sub>2</sub>
	[mm]	[mm]	[mm]	[mm]	[mm]	[mm]	[mm]	[mm]	[mm]	[mm]	[mm]	[mm]
<b>063</b>	255	123	109	17.0	136	103	318	123	109	17.0	136	103
<b>071</b>	297	139	118	23.5			338	139	133	13.0		
<b>080</b>	369	158	132	25.0	152	121	379	156	142	24.0	194	125
<b>090</b>	392	178	137	29.0			410	176	147	28.0		
<b>100</b>	463	196	147	36.0			479	194	158	35.0		
<b>112</b>	472	220	158	38.0			509	218	168	37.0		
<b>132</b>	599	261	187	51.0	194	125	621	258	187	51.0	226	127
<b>160</b>	735	313	210	65.0	226	127	833	313	210	65.0		
<b>180</b>	750	351	230	79.0			863	351	230	79.0		

	d	d	d <sub>2</sub>	l	l <sub>1</sub>	l <sub>2</sub>	t	u
	j6	k6						
	[mm]	[mm]	[mm]	[mm]	[mm]	[mm]	[mm]	[mm]
<b>063</b>	11		M4	23	3.5	16	12.5	4.0
<b>071</b>	14		M5	30	4.0	22	16.0	5.0
<b>080</b>	19		M6	40		32	21.5	6.0
<b>090</b>	24		M8	50	5.0	40	27.0	8.0
<b>100</b>	28		M10	60		50	31.0	
<b>112</b>			38	M12		80	70	41.0
<b>132</b>		42	M16	110		100	45.0	12.0
<b>160</b>		48			51.5		14.0	
<b>180</b>								

	Flange size	a <sub>2</sub>	b <sub>2</sub>	c <sub>2</sub>	e <sub>2</sub>	f <sub>2</sub>	s <sub>2</sub>	i <sub>2</sub>
			j6					
		[mm]	[mm]	[mm]	[mm]	[mm]	[mm]	[mm]
<b>063</b>	FF115	140	95	10	115	3.0	10.0	23
<b>071</b>	FF130	160	110		130	3.5		30
<b>080</b>	FF165	200	130	11	165	3.5	12.0	40
<b>090</b>								50
<b>100</b>	FF215	250	180	15	215	4.0	14.5	60
<b>112</b>	FF265	300	230	20	265			80
<b>132</b>	FF300	350	250	13	300	5.0	18.5	110
<b>160</b>								
<b>180</b>								

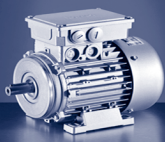

## Dimensions MDEMA, B14

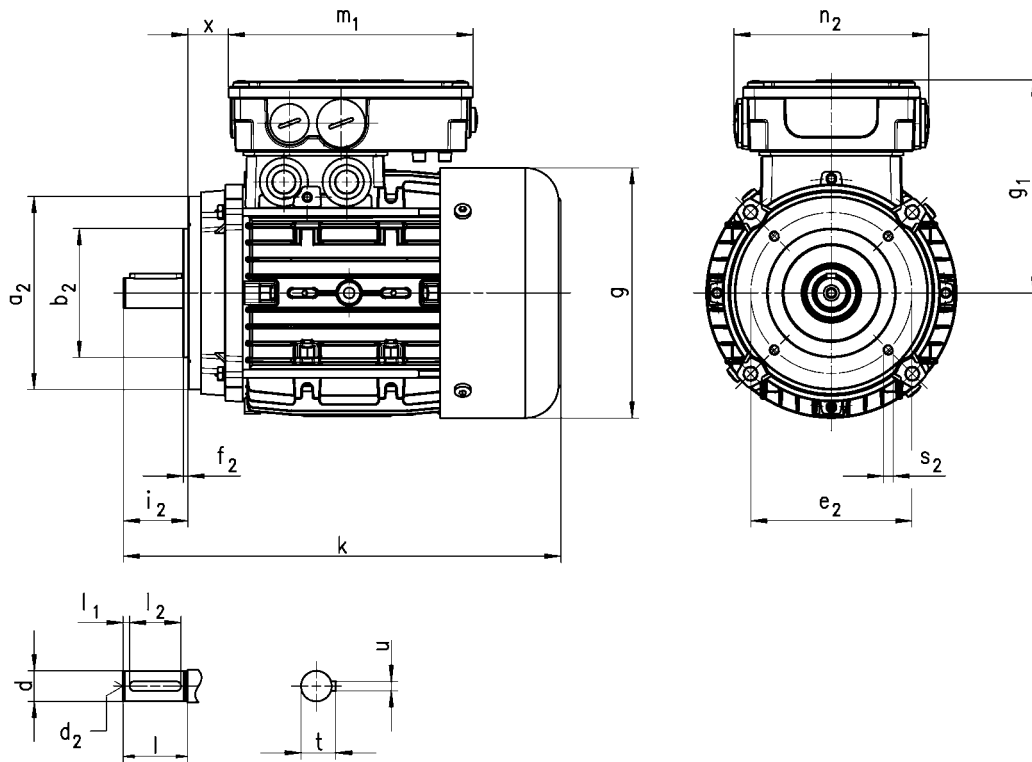

Motor type	MDEMAXX						MDEMABR					
	k	g	g <sub>1</sub>	x	m <sub>1</sub>	n <sub>2</sub>	k	g	g <sub>1</sub>	x	m <sub>1</sub>	n <sub>2</sub>
	[mm]	[mm]	[mm]	[mm]	[mm]	[mm]	[mm]	[mm]	[mm]	[mm]	[mm]	[mm]
<b>063</b>	215	123	109	17.0	136	103	255	123	109	17.0	136	103
<b>071</b>	246	139	118	23.5			297	139	118	23.5		
<b>080</b>	272	156	132	25.0	152	121	345	154	132	25.0	152	121
<b>090</b>	311	176	137	29.0			373	176	137	29.0		
<b>100</b>	382	194	147	36.0			458	194	147	36.0		
<b>112</b>	392	218	158	38.0			479	218	158	38.0		

Motor type	MDEMARS MDEMAIG MDEMAAG						MDEMABS MDEMABI MDEMABA					
	k	g	g <sub>1</sub>	x	m <sub>1</sub>	n <sub>2</sub>	k	g	g <sub>1</sub>	x	m <sub>1</sub>	n <sub>2</sub>
	[mm]	[mm]	[mm]	[mm]	[mm]	[mm]	[mm]	[mm]	[mm]	[mm]	[mm]	[mm]
<b>063</b>	255	123	109	17.0	136	103	318	123	109	17.0	136	103
<b>071</b>	297	139	118	23.5			338	139	133	13.0		
<b>080</b>	369	158	132	25.0	152	121	379	156	142	24.0	194	125
<b>090</b>	392	178	137	29.0			410	176	147	28.0		
<b>100</b>	463	196	147	36.0			479	194	158	35.0		
<b>112</b>	472	220	158	38.0			509	218	168	37.0		



	d	d	d <sub>2</sub>	l	l <sub>1</sub>	l <sub>2</sub>	t	u
	j6	k6						
	[mm]	[mm]	[mm]	[mm]	[mm]	[mm]	[mm]	[mm]
<b>063</b>	11		M4	23	3.5	16	12.5	4.0
<b>071</b>	14		M5	30	4.0	22	16.0	5.0
<b>080</b>	19		M6	40		32	21.5	6.0
<b>090</b>	24		M8	50	5.0	40	27.0	8.0
<b>100</b>	28		M10	60		50	31.0	
<b>112</b>								

	Flange size	a <sub>2</sub>	b <sub>2</sub>	e <sub>2</sub>	f <sub>2</sub>	s <sub>2</sub>	i <sub>2</sub>
			j6				
		[mm]	[mm]	[mm]	[mm]	[mm]	[mm]
<b>063</b>	FT75	90	60	75	2.5	M5x10	23
<b>071</b>	FT85	105	70	85		M6x10	30
<b>080</b>	FT100	120	80	100	3.0	M6x12	40
	FT130	160	110	130	3.5	M8x14	
<b>090</b>	FT115	140	95	115	3.0	M8x16	50
<b>100</b>	FT130	160	110	130	3.5	M8x14	60
<b>112</b>						M8x16	



# Dimensions

## MDFMA, B3

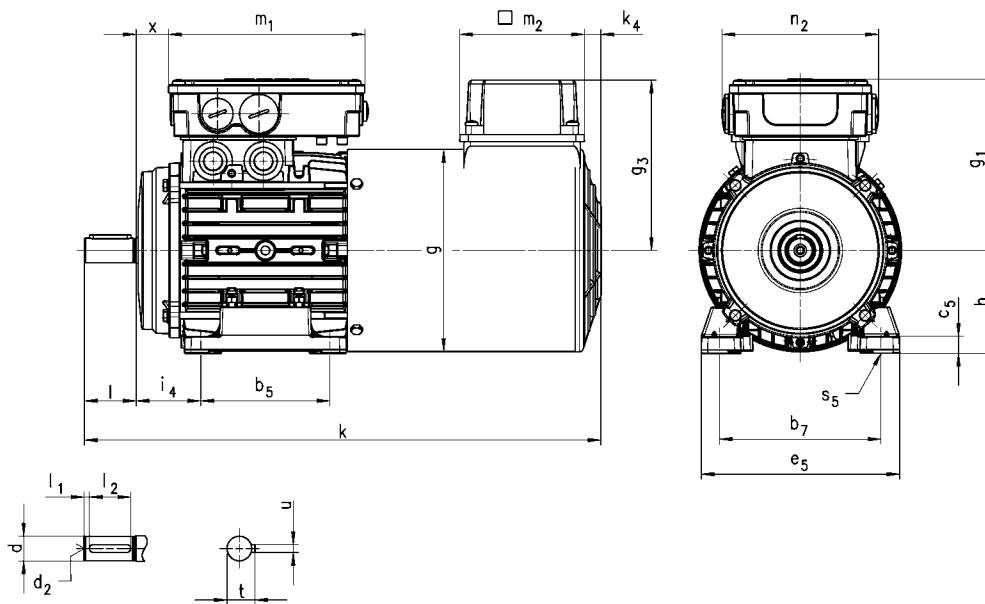

Motor type	MDFMAXX										MDFMABR								
	k	g	g <sub>1</sub>	x	m <sub>1</sub>	n <sub>2</sub>	g <sub>3</sub>	k <sub>4</sub>	m <sub>2</sub>	k	g	g <sub>1</sub>	x	m <sub>1</sub>	n <sub>2</sub>	g <sub>3</sub>	k <sub>4</sub>	m <sub>2</sub>	
	[mm]	[mm]	[mm]	[mm]	[mm]	[mm]	[mm]	[mm]	[mm]	[mm]	[mm]	[mm]	[mm]	[mm]	[mm]	[mm]	[mm]	[mm]	
063	345	123	109	17.0	136	103	115	12	95	385	123	109	17.0	136	103	115	12	95	
071	373	138	118	23.5			122			410	138	118	23.5			122			
080	400	156	132	25.0	152	121	132	13	96	455	156	132	25.0	152	121	132	13	96	
090	434	176	137	29.0			141			487	176	137	29.0			141			
100	491	194	147	36.0	152	121	150	22	95	552	194	147	36.0	152	121	150	22	95	
112	494	218	158	38.0			162			575	218	158	38.0			162			
132	612	257	187	51.0	194	125	182	32	96	698	257	187	51.0	194	125	182	32	96	
160	791	309	210	65.0	226	127	209	31	96	821	309	210	65.0	226	127	209	31	96	
180	820	348	230	79.0						871	348	230	79.0						871

Motor type	MDFMARS MDFMAIG MDFMAAG										MDFMABS MDFMABI MDFMABA								
	k	g	g <sub>1</sub>	x	m <sub>1</sub>	n <sub>2</sub>	g <sub>3</sub>	k <sub>4</sub>	m <sub>2</sub>	k	g	g <sub>1</sub>	x	m <sub>1</sub>	n <sub>2</sub>	g <sub>3</sub>	k <sub>4</sub>	m <sub>2</sub>	
	[mm]	[mm]	[mm]	[mm]	[mm]	[mm]	[mm]	[mm]	[mm]	[mm]	[mm]	[mm]	[mm]	[mm]	[mm]	[mm]	[mm]	[mm]	
063	345	123	109	17.0	136	103	115	12	95	385	123	109	17.0	136	103	115	12	95	
071	373	138	118	23.5			122			410	138	133	13.0			122			
080	400	156	132	25.0	152	121	132	13	96	455	156	142	24.0	194	125	132	13	96	
090	434	176	137	29.0			141			487	176	147	28.0			141			
100	491	194	147	36.0	152	121	150	22	95	552	194	158	35.0	194	125	150	22	95	
112	575	218	158	38.0			162			575	218	168	37.0			162			
132	698	257	187	51.0	194	125	182	32	96	698	257	187	51.0	194	125	182	32	96	
160	866	309	210	65.0	226	127	209	31	96	821	309	210	65.0	226	127	209	31	96	
180	886	348	230	79.0						931	348	230	79.0						931



	d	d	d <sub>2</sub>	l	l <sub>1</sub>	l <sub>2</sub>	t	u
	j6	k6						
	[mm]	[mm]	[mm]	[mm]	[mm]	[mm]	[mm]	[mm]
<b>063</b>	11		M4	23	3.5	16	12.5	4.0
<b>071</b>	14		M5	30	4.0	22	16.0	5.0
<b>080</b>	19		M6	40		32	21.5	6.0
<b>090</b>	24		M8	50	5.0	40	27.0	8.0
<b>100</b>	28		M10	60		50	31.0	
<b>112</b>			M12	80		70	41.0	10.0
<b>132</b>			38	M16		110	100	45.0
<b>160</b>			42			51.5		14.0
<b>180</b>			48					

	b <sub>7</sub>	i <sub>4</sub>	b <sub>5</sub>	e <sub>5</sub>	h	c <sub>5</sub>	s <sub>5</sub>
	[mm]	[mm]	[mm]	[mm]	[mm]	[mm]	[mm]
<b>063</b>	100	40	80	120	63	10.0	7.0
<b>071</b>	112	45	90	134	71	10.5	
<b>080</b>	125	50	100	154	80	13.0	10.0
<b>090</b>	140	56		174	90		
<b>100</b>	160	63	140	194	100	15.0	12.0
<b>112</b>	190	70		223	112	14.0	
<b>132</b>	216	89		178	260	132	
<b>160</b>	254	108	210 <sup>1)</sup>	305	160	22.0	14.5
			254 <sup>2)</sup>				
<b>180</b>	279	121	241 <sup>3)</sup>	350	180	23.0	
			279 <sup>4)</sup>				

<sup>1)</sup> 160-22

<sup>2)</sup> 160-32

<sup>3)</sup> 180-12

<sup>4)</sup> 180-32



# Dimensions

## MDFMA, B5

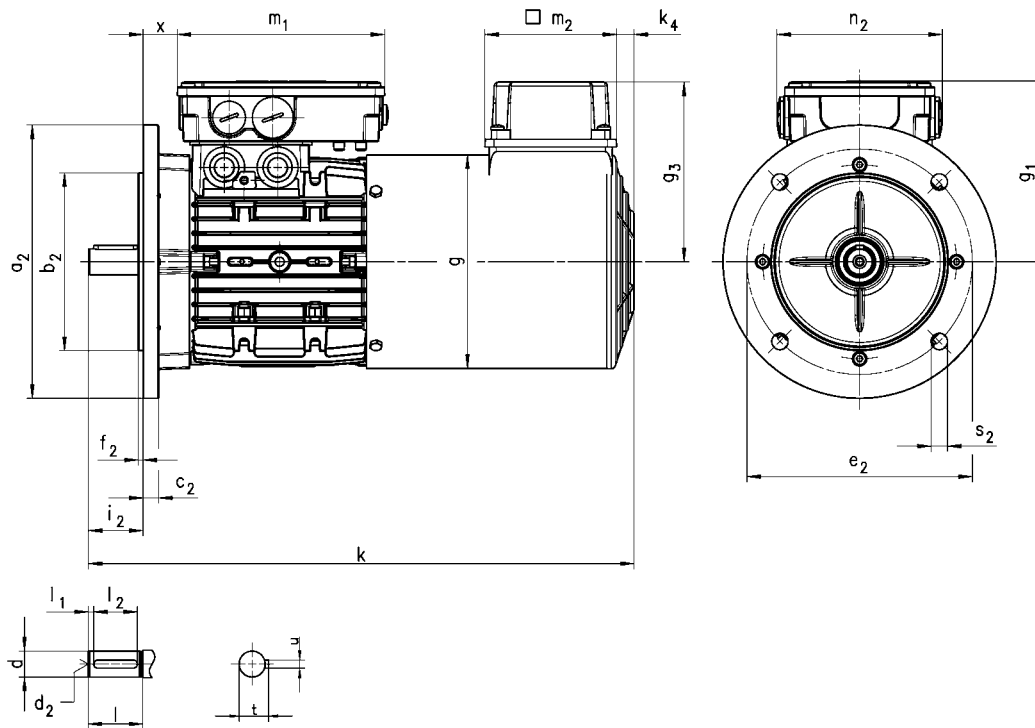

Motor type	MDFMAXX									MDFMABR								
	k	g	g <sub>1</sub>	x	m <sub>1</sub>	n <sub>2</sub>	g <sub>3</sub>	k <sub>4</sub>	m <sub>2</sub>	k	g	g <sub>1</sub>	x	m <sub>1</sub>	n <sub>2</sub>	g <sub>3</sub>	k <sub>4</sub>	m <sub>2</sub>
	[mm]	[mm]	[mm]	[mm]	[mm]	[mm]	[mm]	[mm]	[mm]	[mm]	[mm]	[mm]	[mm]	[mm]	[mm]	[mm]	[mm]	[mm]
063	345	123	109	17.0	136	103	115	12	95	385	123	109	17.0	136	103	115	12	95
071	373	138	118	23.5			122	13	96	410	138	118	23.5			122	13	96
080	400	156	132	25.0	152	121	132	13	96	455	156	132	25.0	152	121	132	13	96
090	434	176	137	29.0			141	22	95	487	176	137	29.0			141	22	95
100	491	194	147	36.0			150	22	95	552	194	147	36.0			150	22	95
112	494	218	158	38.0			162	32	96	575	218	158	38.0			162	32	96
132	612	257	187	51.0	194	125	182	32	96	698	257	187	51.0	194	125	182	32	96
160	791	309	210	65.0	226	127	209	31	96	821	309	210	65.0	226	127	209	31	96
180	820	348	230	79.0			209	31	96	871	348	230	79.0			209	31	96

Motor type	MDFMARS MDFMAIG MDFMAAG									MDFMABS MDFMABI MDFMABA								
	k	g	g <sub>1</sub>	x	m <sub>1</sub>	n <sub>2</sub>	g <sub>3</sub>	k <sub>4</sub>	m <sub>2</sub>	k	g	g <sub>1</sub>	x	m <sub>1</sub>	n <sub>2</sub>	g <sub>3</sub>	k <sub>4</sub>	m <sub>2</sub>
	[mm]	[mm]	[mm]	[mm]	[mm]	[mm]	[mm]	[mm]	[mm]	[mm]	[mm]	[mm]	[mm]	[mm]	[mm]	[mm]	[mm]	[mm]
063	345	123	109	17.0	136	103	115	12	95	385	123	109	17.0	136	103	115	12	95
071	373	138	118	23.5			122	13	96	410	138	133	13.0			122	13	96
080	400	156	132	25.0	152	121	132	13	96	455	156	142	24.0	194	125	132	13	96
090	434	176	137	29.0			141	22	95	487	176	147	28.0			141	22	95
100	491	194	147	36.0			150	22	95	552	194	158	35.0			150	22	95
112	575	218	158	38.0			162	32	96	575	218	168	37.0			162	32	96
132	698	257	187	51.0	194	125	182	32	96	698	257	187	51.0	194	125	182	32	96
160	866	309	210	65.0	226	127	209	31	96	821	309	210	65.0	226	127	209	31	96
180	886	348	230	79.0			209	31	96	931	348	230	79.0			209	31	96



	d	d	d <sub>2</sub>	l	l <sub>1</sub>	l <sub>2</sub>	t	u
	j6	k6						
	[mm]	[mm]	[mm]	[mm]	[mm]	[mm]	[mm]	[mm]
<b>063</b>	11		M4	23	3.5	16	12.5	4.0
<b>071</b>	14		M5	30	4.0	22	16.0	5.0
<b>080</b>	19		M6	40		32	21.5	6.0
<b>090</b>	24		M8	50	5.0	40	27.0	8.0
<b>100</b>	28		M10	60		50	31.0	
<b>112</b>			M12	80		70	41.0	10.0
<b>132</b>			38	M16		110	100	45.0
<b>160</b>		42			51.5	14.0		
<b>180</b>		48						

	Flange size	a <sub>2</sub>	b <sub>2</sub>	c <sub>2</sub>	e <sub>2</sub>	f <sub>2</sub>	s <sub>2</sub>	i <sub>2</sub>
			j6					
		[mm]	[mm]	[mm]	[mm]	[mm]	[mm]	[mm]
<b>063</b>	FF115	140	95	10	115	3.0	10.0	23
<b>071</b>	FF130	160	110		130	3.0		30
<b>080</b>	FF165	200	130	11	165	3.5	12.0	40
<b>090</b>								50
<b>100</b>	FF215	250	180	15	215	4.0	14.5	60
<b>112</b>								80
<b>132</b>	FF265	300	230	20	265			
<b>160</b>	FF300	350	250	13	300	5.0	18.5	110
<b>180</b>								

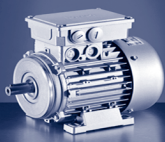

# Dimensions

## MDFMA, B14

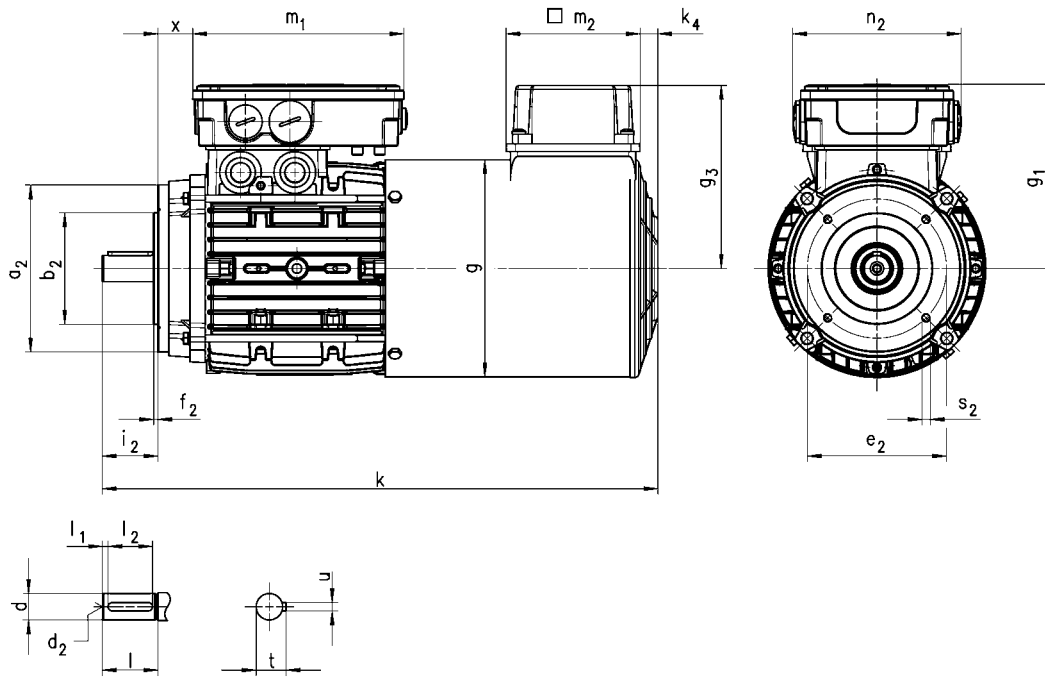

Motor type	MDFMAXX									MDFMABR								
	k	g	g <sub>1</sub>	x	m <sub>1</sub>	n <sub>2</sub>	g <sub>3</sub>	k <sub>4</sub>	m <sub>2</sub>	k	g	g <sub>1</sub>	x	m <sub>1</sub>	n <sub>2</sub>	g <sub>3</sub>	k <sub>4</sub>	m <sub>2</sub>
	[mm]	[mm]	[mm]	[mm]	[mm]	[mm]	[mm]	[mm]	[mm]	[mm]	[mm]	[mm]	[mm]	[mm]	[mm]	[mm]	[mm]	[mm]
<b>063</b>	345	123	109	17.0	136	103	115	12	95	385	123	109	17.0	136	103	115	12	95
<b>071</b>	373	138	118	23.5			122			410	138	118	23.5			122		
<b>080</b>	400	156	132	25.0	152	121	132	13	96	455	156	132	25.0	152	121	132	13	96
<b>090</b>	434	176	137	29.0			141			487	176	137	29.0			141		
<b>100</b>	491	194	147	36.0			150			552	194	147	36.0			150		
<b>112</b>	494	218	158	38.0	162	575	218	158	38.0	162								

Motor type	MDFMARS MDFMAIG MDFMAAG									MDFMABS MDFMABI MDFMABA								
	k	g	g <sub>1</sub>	x	m <sub>1</sub>	n <sub>2</sub>	g <sub>3</sub>	k <sub>4</sub>	m <sub>2</sub>	k	g	g <sub>1</sub>	x	m <sub>1</sub>	n <sub>2</sub>	g <sub>3</sub>	k <sub>4</sub>	m <sub>2</sub>
	[mm]	[mm]	[mm]	[mm]	[mm]	[mm]	[mm]	[mm]	[mm]	[mm]	[mm]	[mm]	[mm]	[mm]	[mm]	[mm]	[mm]	[mm]
<b>063</b>	345	123	109	17.0	136	103	115	12	95	385	123	109	17.0	136	103	115	12	95
<b>071</b>	373	138	118	23.5			122			410	138	133	13.0			122		
<b>080</b>	400	156	132	25.0	152	121	132	13	96	455	156	142	24.0	194	125	132	13	96
<b>090</b>	434	176	137	29.0			141			487	176	147	28.0			141		
<b>100</b>	491	194	147	36.0			150			552	194	158	35.0			150		
<b>112</b>	575	218	158	38.0	162	575	218	168	37.0	162								



	d	d	d <sub>2</sub>	l	l <sub>1</sub>	l <sub>2</sub>	t	u
	j6	k6						
	[mm]	[mm]	[mm]	[mm]	[mm]	[mm]	[mm]	[mm]
<b>063</b>	11		M4	23	3.5	16	12.5	4.0
<b>071</b>	14		M5	30	4.0	22	16.0	5.0
<b>080</b>	19		M6	40		32	21.5	6.0
<b>090</b>	24		M8	50	5.0	40	27.0	8.0
<b>100</b>	28		M10	60		50	31.0	
<b>112</b>								

	Flange size	a <sub>2</sub>	b <sub>2</sub>	e <sub>2</sub>	f <sub>2</sub>	s <sub>2</sub>	i <sub>2</sub>
			j6				
		[mm]	[mm]	[mm]	[mm]	[mm]	[mm]
<b>063</b>	FT75	90	60	75	2.5	M5x10	23
<b>071</b>	FT85	105	70	85		M6x10	30
<b>080</b>	FT100	120	80	100	3.0	M6x12	40
	FT130	160	110	130	3.5	M8x14	
<b>090</b>	FT115	140	95	115	3.0	M8x16	50
<b>100</b>	FT130	160	110	130	3.5	M8x14	60
<b>112</b>						M8x16	



# Dimensions

## MHEMA, B3

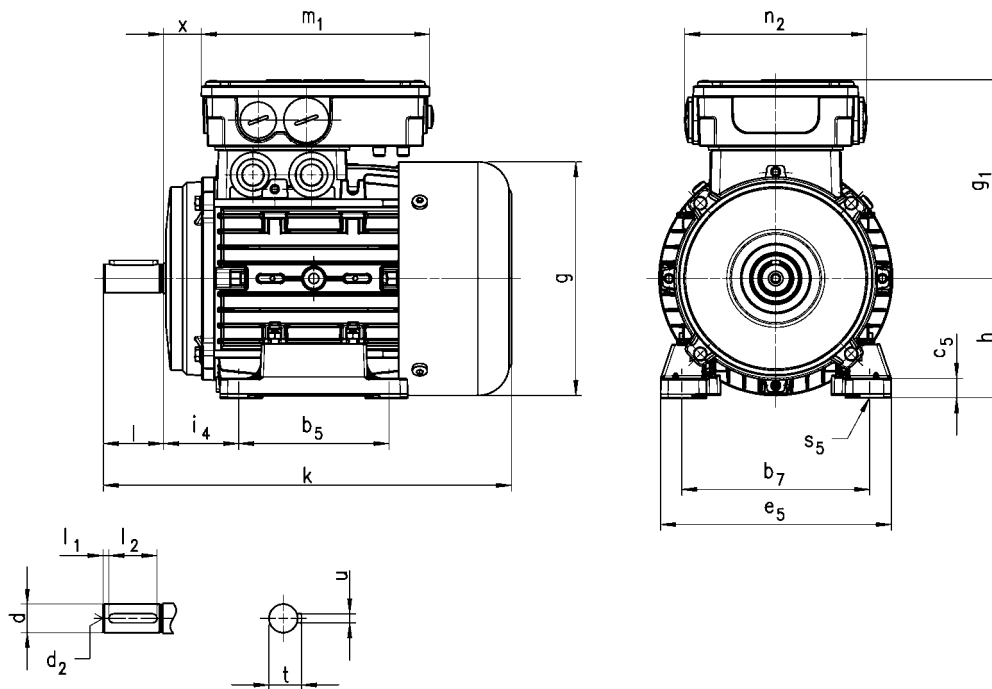

Motor type	MHEMAXX						MHEMABR					
	k	g	g <sub>1</sub>	x	m <sub>1</sub>	n <sub>2</sub>	k	g	g <sub>1</sub>	x	m <sub>1</sub>	n <sub>2</sub>
	[mm]	[mm]	[mm]	[mm]	[mm]	[mm]	[mm]	[mm]	[mm]	[mm]	[mm]	[mm]
080	272	156	132	25.0	152	121	345	154	132	25.0	152	121
090	327	176	137	29.0			399	176	137	29.0		
100	382 <sup>1)</sup>	194	147	36.0			458 <sup>1)</sup>	194	147	36.0		
	397 <sup>2)</sup>						473 <sup>2)</sup>					
112	392	218	158	38.0			479	218	158	38.0		
132	497	258	187	51.0	194	125	576	258	187	51.0	194	125
160	642	310	210	65.0	226	127	747	313	210	65.0	226	127
180	669	348	230	79.0			784	351	230	79.0		
200	728	351					841					

Motor type	MHEMARS MHEMAIG MHEMAAG						MHEMABS MHEMABI MHEMABA					
	k	g	g <sub>1</sub>	x	m <sub>1</sub>	n <sub>2</sub>	k	g	g <sub>1</sub>	x	m <sub>1</sub>	n <sub>2</sub>
	[mm]	[mm]	[mm]	[mm]	[mm]	[mm]	[mm]	[mm]	[mm]	[mm]	[mm]	[mm]
080	369	158	132	25.0	152	121	379	156	142	24.0	194	125
090	418	178	137	29.0			436	176	147	28.0		
100	463 <sup>1)</sup>	196	147	36.0			479 <sup>1)</sup>	194	158	35.0		
	478 <sup>2)</sup>						494 <sup>2)</sup>					
112	472	220	158	38.0			509	218	168	37.0		
132	599	261	187	51.0	194	125	621	258	187	51.0		
160	735	313	210	65.0	226	127	833	313	210	65.0	226	127
180	750	351	230	79.0			863	351	230	79.0		
200	807						920					

<sup>1)</sup> 100-12

<sup>2)</sup> 100-32



	d	d	d	d <sub>2</sub>	l	l <sub>1</sub>	l <sub>2</sub>	t	u
	j6	k6	m6						
	[mm]	[mm]	[mm]	[mm]	[mm]	[mm]	[mm]	[mm]	[mm]
<b>080</b>	19			M6	40	4.0	32	21.5	6.0
<b>090</b>	24			M8	50	5.0	40	27.0	8.0
<b>100</b>	28			M10	60		50	31.0	
<b>112</b>				M12	80		70	41.0	
<b>132</b>				38	M16	110	100	45.0	12.0
<b>160</b>		42	51.5	14.0					
<b>180</b>		48	59.0	16.0					
<b>200</b>			55	M20					

	b <sub>7</sub>	i <sub>4</sub>	b <sub>5</sub>	e <sub>5</sub>	h	c <sub>5</sub>	s <sub>5</sub>
	[mm]	[mm]	[mm]	[mm]	[mm]	[mm]	[mm]
<b>080</b>	125	50	100	154	80	13.0	10.0
<b>090</b>	140	56		174	90		
<b>100</b>	160	63	140	194	100	15.0	12.0
<b>112</b>	190	70		223	112	14.0	
<b>132</b>	216	89	178	260	132	18.0	14.5
<b>160</b>	254	108	210 <sup>1)</sup>	305	160	22.0	
			254 <sup>2)</sup>				
<b>180</b>	279	121	241 <sup>3)</sup>	350	180	23.0	
			279 <sup>4)</sup>				
<b>200</b>	318	133	305	400	200	32.0	18.5

<sup>1)</sup> 160-22

<sup>2)</sup> 160-32

<sup>3)</sup> 180-12

<sup>4)</sup> 180-32

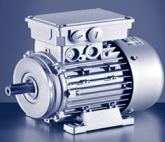

## Dimensions MHEMA, B5

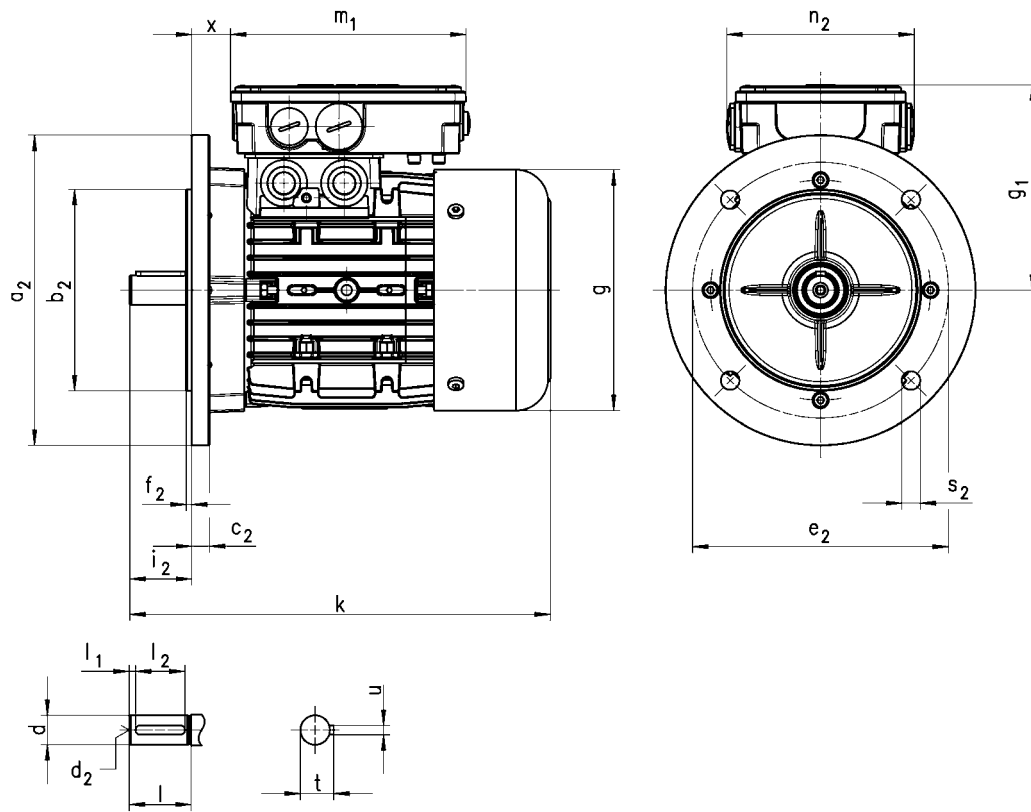

Motor type	MHEMAXX						MHEMABR					
	k	g	g <sub>1</sub>	x	m <sub>1</sub>	n <sub>2</sub>	k	g	g <sub>1</sub>	x	m <sub>1</sub>	n <sub>2</sub>
	[mm]	[mm]	[mm]	[mm]	[mm]	[mm]	[mm]	[mm]	[mm]	[mm]	[mm]	[mm]
<b>080</b>	272	156	132	25.0	152	121	345	154	132	25.0	152	121
<b>090</b>	327	176	137	29.0			399	176	137	29.0		
<b>100</b>	382 <sup>1)</sup>	194	147	36.0			458 <sup>1)</sup>	194	147	36.0		
	397 <sup>2)</sup>						473 <sup>2)</sup>					
<b>112</b>	392	218	158	38.0			479	218	158	38.0		
<b>132</b>	497	258	187	51.0	194	125	576	258	187	51.0	194	125
<b>160</b>	642	310	210	65.0	226	127	747	313	210	65.0	226	127
<b>180</b>	669	348	230	79.0			784	351	230	79.0		
<b>200</b>	728	351					841					

<sup>1)</sup> 100-12

<sup>2)</sup> 100-32



Motor type	MHEMARS MHEMAIG MHEMAAG						MHEMABS MHEMABI MHEMABA					
	k	g	g <sub>1</sub>	x	m <sub>1</sub>	n <sub>2</sub>	k	g	g <sub>1</sub>	x	m <sub>1</sub>	n <sub>2</sub>
	[mm]	[mm]	[mm]	[mm]	[mm]	[mm]	[mm]	[mm]	[mm]	[mm]	[mm]	[mm]
<b>080</b>	369	158	132	25.0	152	121	379	156	142	24.0	194	125
<b>090</b>	418	178	137	29.0			436	176	147	28.0		
<b>100</b>	463 <sup>1)</sup>	196	147	36.0			479 <sup>1)</sup>	194	158	35.0		
	478 <sup>2)</sup>						494 <sup>2)</sup>					
<b>112</b>	472	220	158	38.0			509	218	168	37.0		
<b>132</b>	599	261	187	51.0	194	125	621	258	187	51.0		
<b>160</b>	735	313	210	65.0	226	127	833	313	210	65.0	226	127
<b>180</b>	750	351	230	79.0			863	351	230	79.0		
<b>200</b>	807						920					

<sup>1)</sup> 100-12

<sup>2)</sup> 100-32

	d	d	d	d <sub>2</sub>	l	l <sub>1</sub>	l <sub>2</sub>	t	u
	j6	k6	m6						
	[mm]	[mm]	[mm]	[mm]	[mm]	[mm]	[mm]	[mm]	[mm]
<b>080</b>	19			M6	40	4.0	32	21.5	6.0
<b>090</b>	24			M8	50		40	27.0	
<b>100</b>	28			M10	60		50	31.0	
<b>112</b>				M12	80				70
<b>132</b>				38	M16		110	100	45.0
<b>160</b>		42	51.5	14.0					
<b>180</b>		48	59.0	16.0					
<b>200</b>			55	M20					

	Flange size								
		a <sub>2</sub>	b <sub>2</sub>	b <sub>2</sub>	c <sub>2</sub>	e <sub>2</sub>	f <sub>2</sub>	s <sub>2</sub>	i <sub>2</sub>
			j6	h6					
		[mm]	[mm]	[mm]	[mm]	[mm]	[mm]	[mm]	[mm]
<b>080</b>	FF165	200	130		11	165	3.5	12.0	40
<b>090</b>									50
<b>100</b>	FF215	250	180		15	215	4.0	14.5	60
<b>112</b>									80
<b>132</b>	FF265	300	230		20				
<b>160</b>	FF300	350	250		13	300	5.0	18.5	110
<b>180</b>									
<b>200</b>	FF350	400		300	17	350			



## Dimensions MHEMA, B14

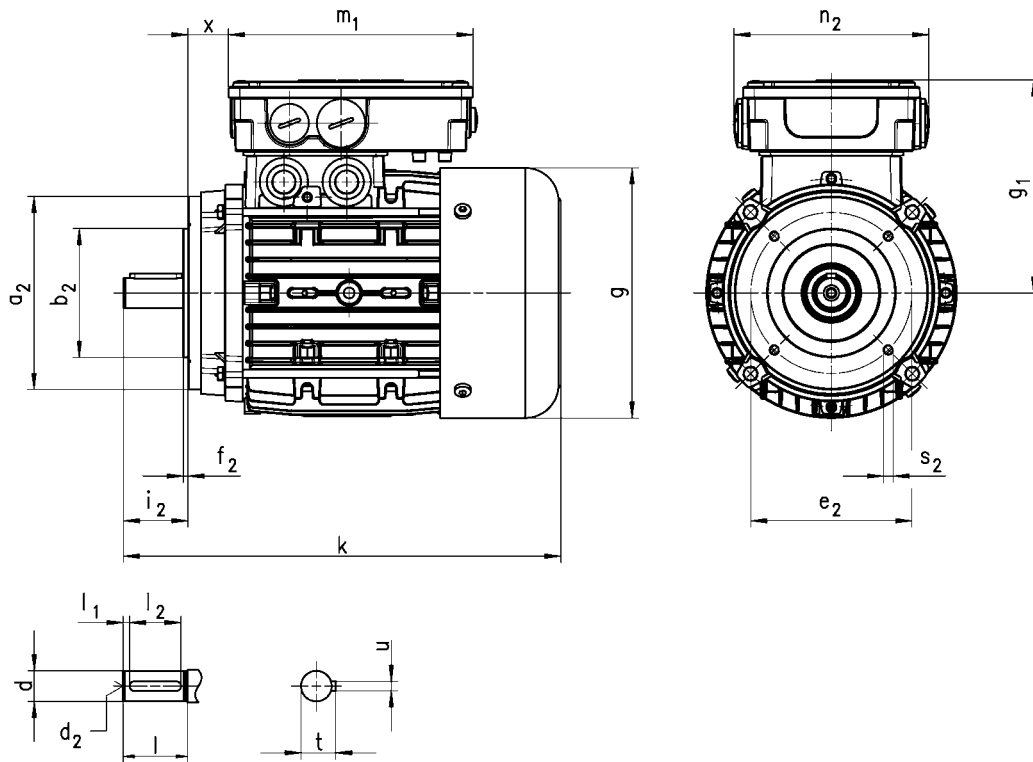

Motor type	MHEMAXX						MHEMABR					
	k	g	g <sub>1</sub>	x	m <sub>1</sub>	n <sub>2</sub>	k	g	g <sub>1</sub>	x	m <sub>1</sub>	n <sub>2</sub>
	[mm]	[mm]	[mm]	[mm]	[mm]	[mm]	[mm]	[mm]	[mm]	[mm]	[mm]	[mm]
080	272	156	132	25.0	152	121	345	154	132	25.0	152	121
090	327	176	137	29.0			399	176	137	29.0		
100	382 <sup>1)</sup>	194	147	36.0			458 <sup>1)</sup>	194	147	36.0		
	397 <sup>2)</sup>						473 <sup>2)</sup>					
112	392	218	158	38.0	479	218	158	38.0				

Motor type	MHEMARS MHEMAIG MHEMAAG						MHEMABS MHEMABI MHEMABA					
	k	g	g <sub>1</sub>	x	m <sub>1</sub>	n <sub>2</sub>	k	g	g <sub>1</sub>	x	m <sub>1</sub>	n <sub>2</sub>
	[mm]	[mm]	[mm]	[mm]	[mm]	[mm]	[mm]	[mm]	[mm]	[mm]	[mm]	[mm]
080	369	158	132	25.0	152	121	379	156	142	24.0	194	125
090	418	178	137	29.0			436	176	147	28.0		
100	463 <sup>1)</sup>	196	147	36.0			479 <sup>1)</sup>	194	158	35.0		
	478 <sup>2)</sup>						494 <sup>2)</sup>					
112	472	220	158	38.0	509	218	168	37.0				

<sup>1)</sup> 100-12

<sup>2)</sup> 100-32



	d	d	d <sub>2</sub>	l	l <sub>1</sub>	l <sub>2</sub>	t	u
	j6	k6						
	[mm]	[mm]	[mm]	[mm]	[mm]	[mm]	[mm]	[mm]
<b>080</b>	19		M6	40	4.0	32	21.5	6.0
<b>090</b>	24		M8	50	5.0	40	27.0	8.0
<b>100</b>	28		M10	60		50	31.0	
<b>112</b>								

Flange size		a <sub>2</sub>	b <sub>2</sub>	e <sub>2</sub>	f <sub>2</sub>	s <sub>2</sub>	i <sub>2</sub>
		j6					
		[mm]	[mm]	[mm]	[mm]	[mm]	[mm]
<b>080</b>	FT100	120	80	100	3.0	M6x12	40
	FT130	160	110	130	3.5	M8x16	
<b>090</b>	FT115	140	95	115	3.0	M8x14	50
						M8x16	
<b>100</b>	FT130	160	110	130	3.5	M8x14	60
<b>112</b>						M8x16	



## Dimensions MHFMA, B3

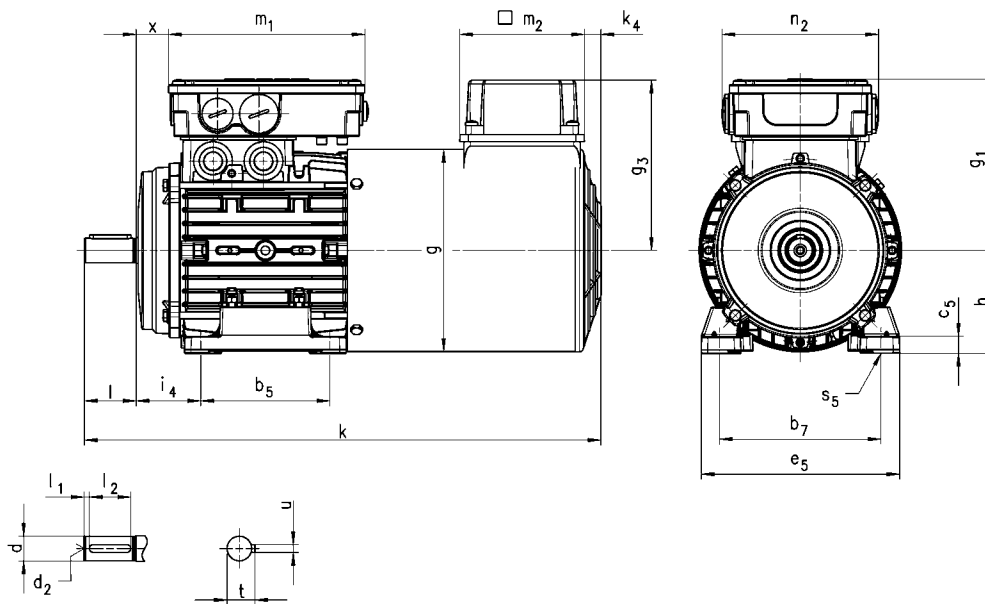

Motor type	MHFMAXX									MHFMABR								
	k	g	g <sub>1</sub>	x	m <sub>1</sub>	n <sub>2</sub>	g <sub>3</sub>	k <sub>4</sub>	m <sub>2</sub>	k	g	g <sub>1</sub>	x	m <sub>1</sub>	n <sub>2</sub>	g <sub>3</sub>	k <sub>4</sub>	m <sub>2</sub>
	[mm]	[mm]	[mm]	[mm]	[mm]	[mm]	[mm]	[mm]	[mm]	[mm]	[mm]	[mm]	[mm]	[mm]	[mm]	[mm]	[mm]	[mm]
<b>080</b>	400	156	132	25.0			132	13	96	455	156	132	25.0			132	13	96
<b>090</b>	460	176	137	29.0			141			513	176	137	29.0			141		
<b>100</b>	491 <sup>1)</sup>	194	147	36.0	152	121	150	22	95	552 <sup>1)</sup>	194	147	36.0	152	121	150	22	95
	506 <sup>2)</sup>									567 <sup>2)</sup>								
<b>112</b>	494	218	158	38.0			162			575	218	158	38.0			162		
<b>132</b>	612	257	187	51.0	194	125	182	32		698	257	187	51.0	194	125	182	32	
<b>160</b>	791	309	210	65.0					96	821	309	210	65.0					96
<b>180</b>	820	348	230	79.0	226	127	209	31		871	348	230	79.0	226	127	209	31	
<b>200</b>	883	351							943	351	106							943

Motor type	MHFMARS MHFMAIG MHFMAAG									MHFMABS MHFMABI MHFMABA								
	k	g	g <sub>1</sub>	x	m <sub>1</sub>	n <sub>2</sub>	g <sub>3</sub>	k <sub>4</sub>	m <sub>2</sub>	k	g	g <sub>1</sub>	x	m <sub>1</sub>	n <sub>2</sub>	g <sub>3</sub>	k <sub>4</sub>	m <sub>2</sub>
	[mm]	[mm]	[mm]	[mm]	[mm]	[mm]	[mm]	[mm]	[mm]	[mm]	[mm]	[mm]	[mm]	[mm]	[mm]	[mm]	[mm]	[mm]
<b>080</b>	400	156	132	25.0			132	13	96	455	156	142	24.0			132	13	96
<b>090</b>	460	176	137	29.0			141			513	176	147	28.0			141		
<b>100</b>	491 <sup>1)</sup>	194	147	36.0	152	121	150	22	95	552 <sup>1)</sup>	194	158	35.0	194	125	150	22	95
	506 <sup>2)</sup>									567 <sup>2)</sup>								
<b>112</b>	575	218	158	38.0			162			575	218	168	37.0			162		
<b>132</b>	698	257	187	51.0	194	125	182	32		698	257	187	51.0			182	32	
<b>160</b>	866	309	210	65.0					96	821	309	210	65.0					96
<b>180</b>	886	348	230	79.0	226	127	209	31		931	348	230	79.0	226	127	209	31	
<b>200</b>	943	351							1003	351	106							1003

<sup>1)</sup> 100-12  
<sup>2)</sup> 100-32



	d	d	d	d <sub>2</sub>	l	l <sub>1</sub>	l <sub>2</sub>	t	u
	j6	k6	m6						
	[mm]	[mm]	[mm]	[mm]	[mm]	[mm]	[mm]	[mm]	[mm]
<b>080</b>	19			M6	40	4.0	32	21.5	6.0
<b>090</b>	24			M8	50		40	27.0	
<b>100</b>	28			M10	60		50	31.0	8.0
<b>112</b>				M12	80	70	41.0	10.0	
<b>132</b>				38	M16	110	5.0	100	45.0
<b>160</b>		42	51.5	14.0					
<b>180</b>		48	59.0	16.0					
<b>200</b>			55	M20					

	b <sub>7</sub>	i <sub>4</sub>	b <sub>5</sub>	e <sub>5</sub>	h	c <sub>5</sub>	s <sub>5</sub>
	[mm]	[mm]	[mm]	[mm]	[mm]	[mm]	[mm]
<b>080</b>	125	50	100	154	80	13.0	10.0
<b>090</b>	140	56		174	90		
<b>100</b>	160	63	140	194	100	15.0	12.0
<b>112</b>	190	70		223	112	14.0	
<b>132</b>	216	89	178	260	132	18.0	14.5
<b>160</b>	254	108	210 <sup>1)</sup>	305	160	22.0	
			254 <sup>2)</sup>				
<b>180</b>	279	121	241 <sup>3)</sup>	350	180	23.0	
			279 <sup>4)</sup>				
<b>200</b>	318	133	305	400	200	32.0	18.5

<sup>1)</sup> 160-22

<sup>2)</sup> 160-32

<sup>3)</sup> 180-12

<sup>4)</sup> 180-32

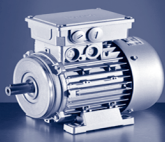

## Dimensions

### MHFMA, B5

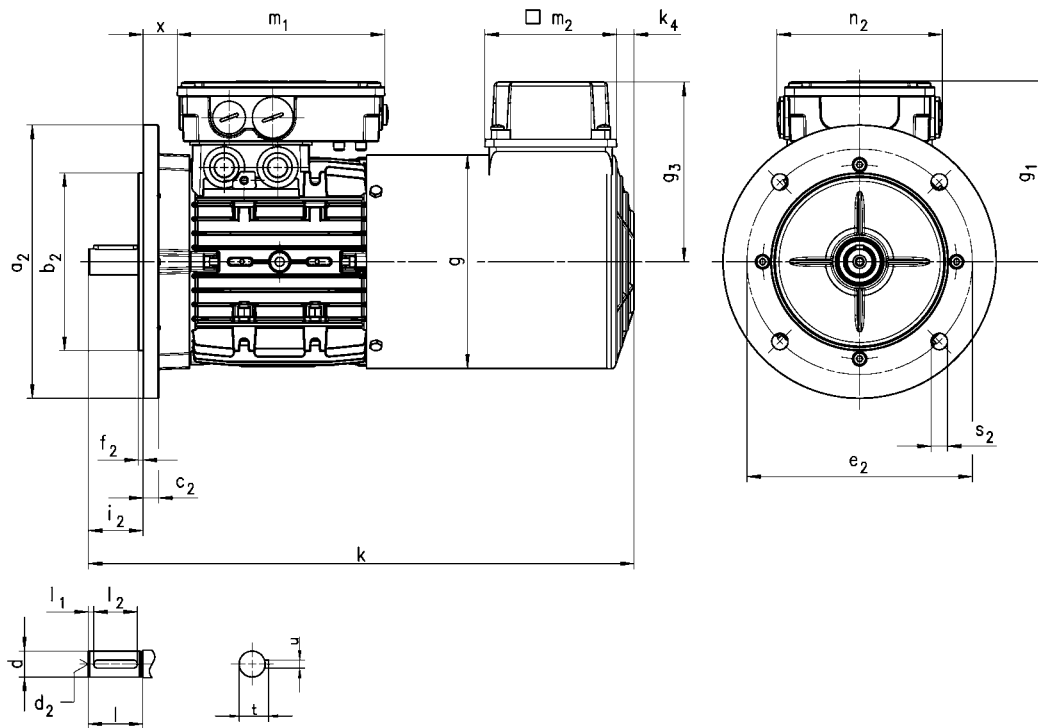

Motor type	MHFMAXX									MHFMABR									
	k	g	g <sub>1</sub>	x	m <sub>1</sub>	n <sub>2</sub>	g <sub>3</sub>	k <sub>4</sub>	m <sub>2</sub>	k	g	g <sub>1</sub>	x	m <sub>1</sub>	n <sub>2</sub>	g <sub>3</sub>	k <sub>4</sub>	m <sub>2</sub>	
	[mm]	[mm]	[mm]	[mm]	[mm]	[mm]	[mm]	[mm]	[mm]	[mm]	[mm]	[mm]	[mm]	[mm]	[mm]	[mm]	[mm]	[mm]	[mm]
<b>080</b>	400	156	132	25.0			132	13	96	455	156	132	25.0			132	13	96	
<b>090</b>	460	176	137	29.0			141			513	176	137	29.0			141			
<b>100</b>	491 <sup>1)</sup>	194	147	36.0	152	121	150	22	95	552 <sup>1)</sup>	194	147	36.0	152	121	150	22	95	
	506 <sup>2)</sup>									567 <sup>2)</sup>									
<b>112</b>	494	218	158	38.0			162			575	218	158	38.0			162			
<b>132</b>	612	257	187	51.0	194	125	182	32		698	257	187	51.0	194	125	182	32		
<b>160</b>	791	309	210	65.0						821	309	210	65.0						
<b>180</b>	820	348	230	79.0	226	127	209	31	96	871	348	230	79.0	226	127	209	31	96	
									106	943								106	
<b>200</b>	883	351								943	351								

<sup>1)</sup> 100-12

<sup>2)</sup> 100-32



Motor type	MHFMARS MHFMAIG MHFMAAG										MHFMABS MHFMABI MHFMABA								
	k	g	g <sub>1</sub>	x	m <sub>1</sub>	n <sub>2</sub>	g <sub>3</sub>	k <sub>4</sub>	m <sub>2</sub>	k	g	g <sub>1</sub>	x	m <sub>1</sub>	n <sub>2</sub>	g <sub>3</sub>	k <sub>4</sub>	m <sub>2</sub>	
	[mm]	[mm]	[mm]	[mm]	[mm]	[mm]	[mm]	[mm]	[mm]	[mm]	[mm]	[mm]	[mm]	[mm]	[mm]	[mm]	[mm]	[mm]	
<b>080</b>	400	156	132	25.0	152	121	132	13	96	455	156	142	24.0	194	125	132	13	96	
<b>090</b>	460	176	137	29.0			141	150	22	95	513	176	147			28.0	141	150	22
<b>100</b>	491 <sup>1)</sup>	194	147	36.0	150	22	95				552 <sup>1)</sup>	194	158	35.0	194	125	150		
	506 <sup>2)</sup>				162	575	218	168	37.0	162									
<b>112</b>	575	218	158	38.0	194	125	182	32	96	698	257	187	51.0	226	127	182	32	96	
<b>132</b>	698	257	187	51.0			182	32		698	257	187	51.0			182	32		
<b>160</b>	866	309	210	65.0	226	127	209	31	96	821	309	210	65.0	226	127	209	31	96	
<b>180</b>	886	348	230	79.0						931	348	230	79.0						931
<b>200</b>	943	351			943	351	106	1003	351	106	1003			351	106	1003	351	106	1003

<sup>1)</sup> 100-12

<sup>2)</sup> 100-32

	d	d	d	d <sub>2</sub>	l	l <sub>1</sub>	l <sub>2</sub>	t	u
	j6	k6	m6						
	[mm]	[mm]	[mm]	[mm]	[mm]	[mm]	[mm]	[mm]	[mm]
<b>080</b>	19			M6	40	4.0	32	21.5	6.0
<b>090</b>	24			M8	50		40	27.0	8.0
<b>100</b>	28			M10	60	5.0	50	31.0	
<b>112</b>				M12	80		70	41.0	
<b>132</b>		38		M16	110	100	100	45.0	12.0
<b>160</b>		42						51.5	14.0
<b>180</b>		48						59.0	16.0
<b>200</b>			55	M20				59.0	16.0

	Flange size	a <sub>2</sub>	b <sub>2</sub>	b <sub>2</sub>	c <sub>2</sub>	e <sub>2</sub>	f <sub>2</sub>	s <sub>2</sub>	i <sub>2</sub>
			j6	h6					
		[mm]	[mm]	[mm]	[mm]	[mm]	[mm]	[mm]	[mm]
<b>080</b>	FF165	200	130		11	165	3.5	12.0	40
<b>090</b>									50
<b>100</b>	FF215	250	180		15	215	4.0	14.5	60
<b>112</b>									80
<b>132</b>	FF265	300	230		20				
<b>160</b>	FF300	350	250		13	300	5.0	18.5	110
<b>180</b>									
<b>200</b>	FF350	400		300	17	350			



## Dimensions

### MHFMA, B14

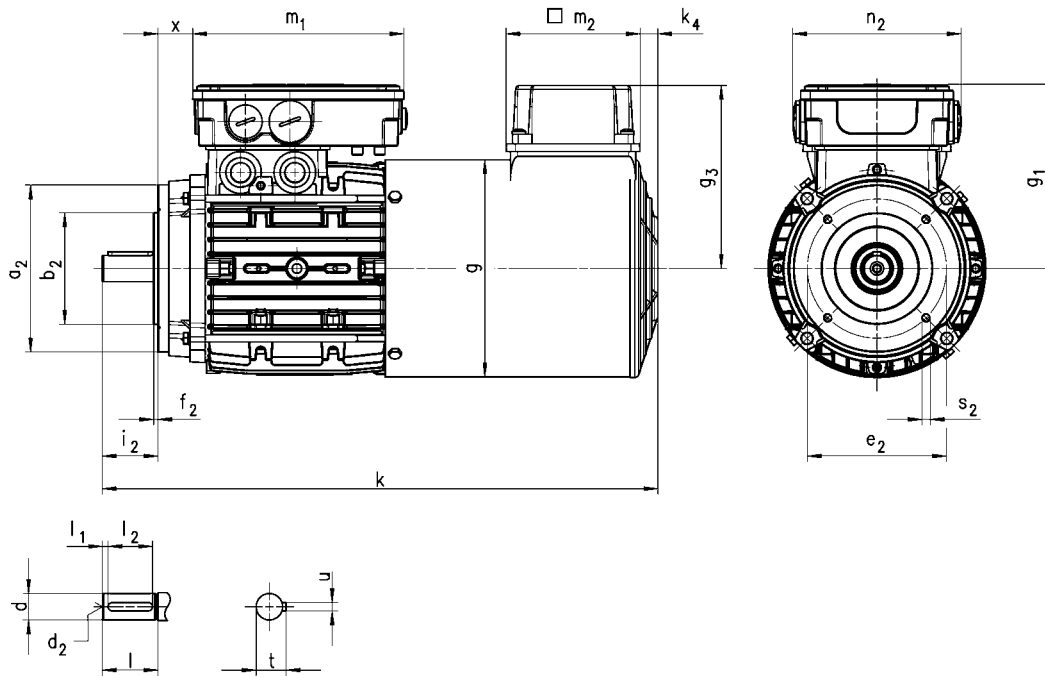

Motor type	MHFMAXX									MHFMABR								
	k	g	g <sub>1</sub>	x	m <sub>1</sub>	n <sub>2</sub>	g <sub>3</sub>	k <sub>4</sub>	m <sub>2</sub>	k	g	g <sub>1</sub>	x	m <sub>1</sub>	n <sub>2</sub>	g <sub>3</sub>	k <sub>4</sub>	m <sub>2</sub>
	[mm]	[mm]	[mm]	[mm]	[mm]	[mm]	[mm]	[mm]	[mm]	[mm]	[mm]	[mm]	[mm]	[mm]	[mm]	[mm]	[mm]	[mm]
<b>080</b>	400	156	132	25.0	152	121	132	13	96	455	156	132	25.0	152	121	132	13	96
<b>090</b>	460	176	137	29.0			141			513	176	137	29.0			141		
<b>100</b>	491 <sup>1)</sup>	194	147	36.0			150	22	95	552 <sup>1)</sup>	194	147	36.0			150	22	95
	506 <sup>2)</sup>						162	575	218	158	38.0	162						
<b>112</b>	494	218	158	38.0				575	218	158	38.0				162			

Motor type	MHFMARS MHFMAIG MHFMAAG									MHFMABS MHFMABI MHFMABA								
	k	g	g <sub>1</sub>	x	m <sub>1</sub>	n <sub>2</sub>	g <sub>3</sub>	k <sub>4</sub>	m <sub>2</sub>	k	g	g <sub>1</sub>	x	m <sub>1</sub>	n <sub>2</sub>	g <sub>3</sub>	k <sub>4</sub>	m <sub>2</sub>
	[mm]	[mm]	[mm]	[mm]	[mm]	[mm]	[mm]	[mm]	[mm]	[mm]	[mm]	[mm]	[mm]	[mm]	[mm]	[mm]	[mm]	[mm]
<b>080</b>	400	156	132	25.0	152	121	132	13	96	455	156	142	24.0	194	125	132	13	96
<b>090</b>	460	176	137	29.0			141			513	176	147	28.0			141		
<b>100</b>	491 <sup>1)</sup>	194	147	36.0			150	22	95	552 <sup>1)</sup>	194	158	35.0			150	22	95
	506 <sup>2)</sup>						162	575	218	168	37.0	162						
<b>112</b>	575	218	158	38.0				575	218	168	37.0				162			

<sup>1)</sup> 100-12

<sup>2)</sup> 100-32



	d	d	d <sub>2</sub>	l	l <sub>1</sub>	l <sub>2</sub>	t	u
	j6	k6						
	[mm]	[mm]	[mm]	[mm]	[mm]	[mm]	[mm]	[mm]
<b>080</b>	19		M6	40	4.0	32	21.5	6.0
<b>090</b>	24		M8	50	5.0	40	27.0	8.0
<b>100</b>	28		M10	60		50	31.0	
<b>112</b>								

Flange size		a <sub>2</sub>	b <sub>2</sub>	e <sub>2</sub>	f <sub>2</sub>	s <sub>2</sub>	i <sub>2</sub>
		j6					
		[mm]	[mm]	[mm]	[mm]	[mm]	[mm]
<b>080</b>	FT100	120	80	100	3.0	M6x12	40
	FT130	160	110	130	3.5	M8x16	
<b>090</b>	FT115	140	95	115	3.0	M8x14	50
						M8x16	
<b>100</b>	FT130	160	110	130	3.5	M8x14	60
<b>112</b>						M8x16	

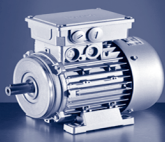

## Dimensions

### Motor connection

#### Motor terminal box with ICN connector

The following positions of the plug-in connector are possible:

- ▶ Power connection (A) in position 5 and return connection (B) in position 3,
- ▶ power connection (A) in position 3 and return connection (B) in position 5
- ▶ In the case of motor sizes 132 ... 180, the return connection (B) is only available in position 3 or 5

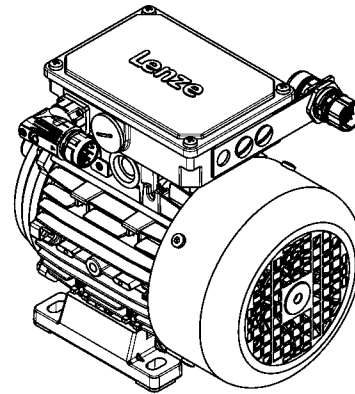
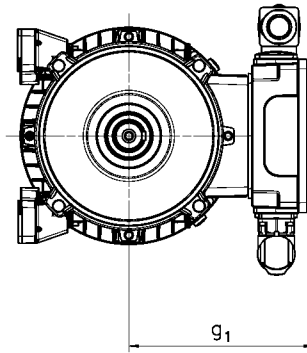
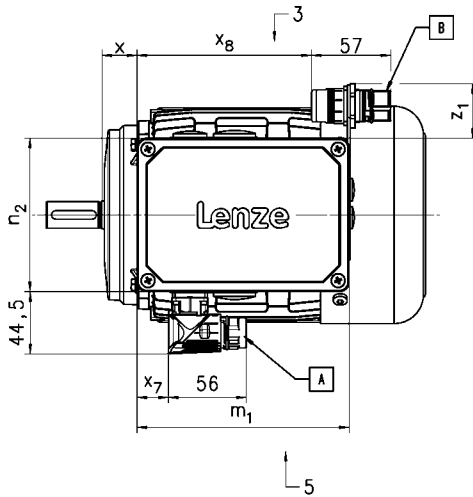

Motor type	M□□MAXX M□□MARS M□□MAIG M□□MAAG			M□□MABR M□□MABS M□□MABI M□□MABA			
	g <sub>1</sub> [mm]	x [mm]	m <sub>1</sub> [mm]	n <sub>2</sub> [mm]	x <sub>7</sub> [mm]	x <sub>8</sub> [mm]	z <sub>1, max</sub> [mm]
063	109	17.0	136	103	16	109	43
071	118	23.5					
080	132	25.0	152	121	23	125	41
090	137	29.0					
100	147	36.0					
112	158	38.0					
132	187	51.0	194	125	27	166	71
160	210	65.0					
180	230	79.0	226	127	83	200	65
200							



### Motor terminal box with HAN-10E / HAN-Modular connector

The connection position for the connector is shown in position 1. Positions 3 and 5 are also possible.

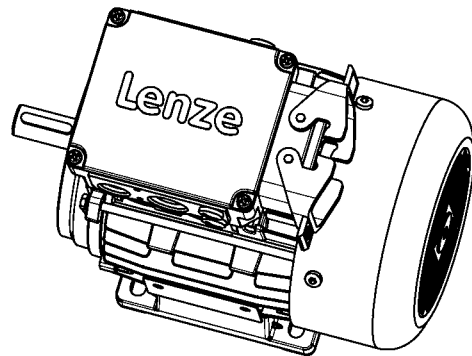
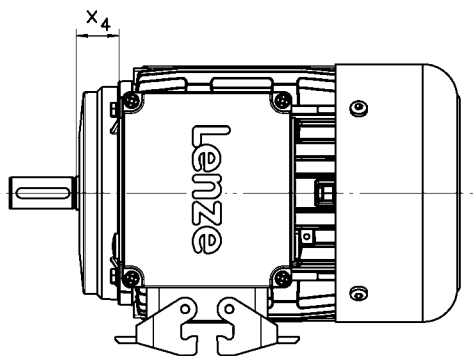
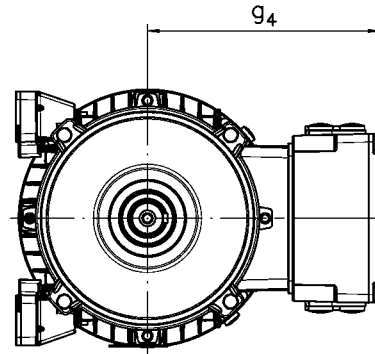
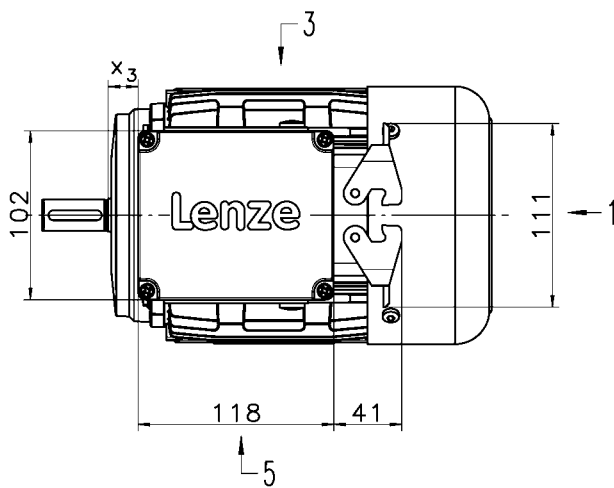

Motor type	M□□MAXX M□□MABR		
	g <sub>4</sub> [mm]	x <sub>3</sub> [mm]	x <sub>4</sub> [mm]
063	120	11	12
071	129	16	17
080	138	18	26
090	143	22	30
100	154	29	37
112	164	28	36
132 <sup>1)</sup>	233	48	18
160	248	72	42
180	267	80	50

<sup>1)</sup> In the case of the B5 type of motor construction, it is not possible to connect the plug-in connector at position 3 or 5.

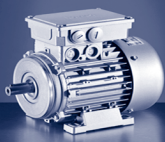

## Dimensions

### Motor connection

#### ICN connector for blower

- ▶ The terminal box for the separate fan is available in positions 2, 3 and 5.
- ▶ In addition, the cover of the fan terminal box (including connectors) can be rotated progressively through 90° if necessary.

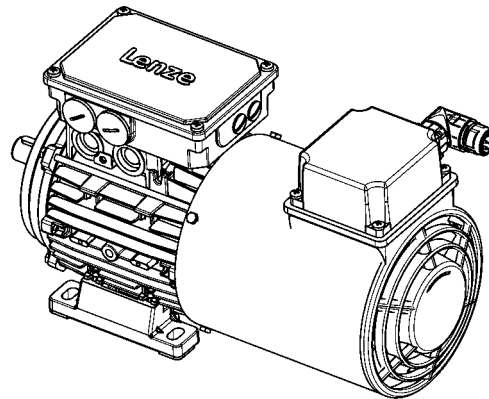
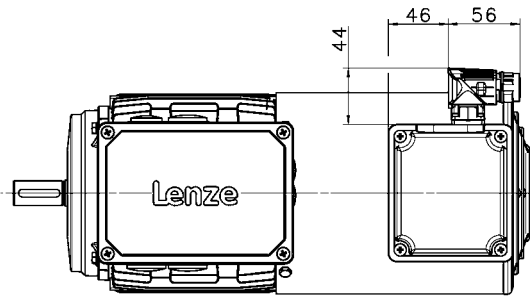
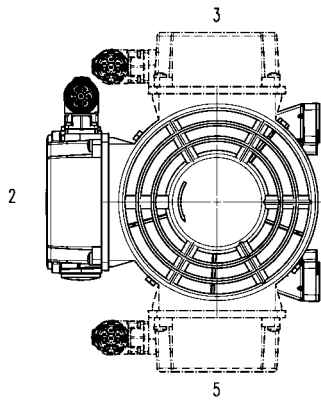



## Decentralised frequency inverter 8200 motec

Rated frequency 50 Hz

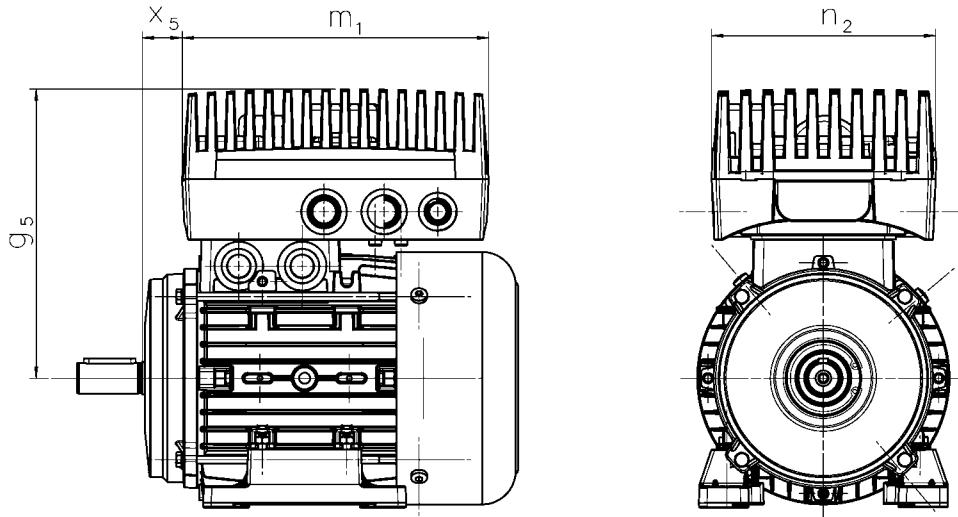

Product key					
Motor	Inverter	$g_5$	$x_5$	$m_1$	$n_2$
		[mm]	[mm]	[mm]	[mm]
MD□MA□□063-12 MD□MA□□063-32 MD□MA□□063-42	E82MV251_2B	171	28	190	103
MD□MA□□071-12 MD□MA□□071-32 MD□MA□□071-42	E82MV371_2B	180	32		138
MD□MA□□080-12 MD□MA□□080-32 MD□MA□□080-42	E82MV551_4B	228	20	202	156
MH□MA□□080-32	E82MV751_4B	223	30		
MD□MA□□090-12 MD□MA□□090-32	E82MV152_4B	239	29	230	176
MH□MA□□090-12 MH□MA□□090-32		244	33		
MD□MA□□100-12 MD□MA□□100-32	E82MV222_4B	255	40		
MH□MA□□100-12 MH□MA□□100-32	E82MV302_4B	271	14		
MD□MA□□112-22 MD□MA□□132-12	E82MV402_4B	281	16	325	211
MH□MA□□112-22 MH□MA□□132-12	E82MV552_4B	300	41		
MD□MA□□132-22 MH□MA□□132-22	E82MV752_4B				

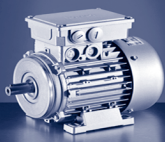

# Dimensions

## Motor connection

Rated frequency 87 Hz

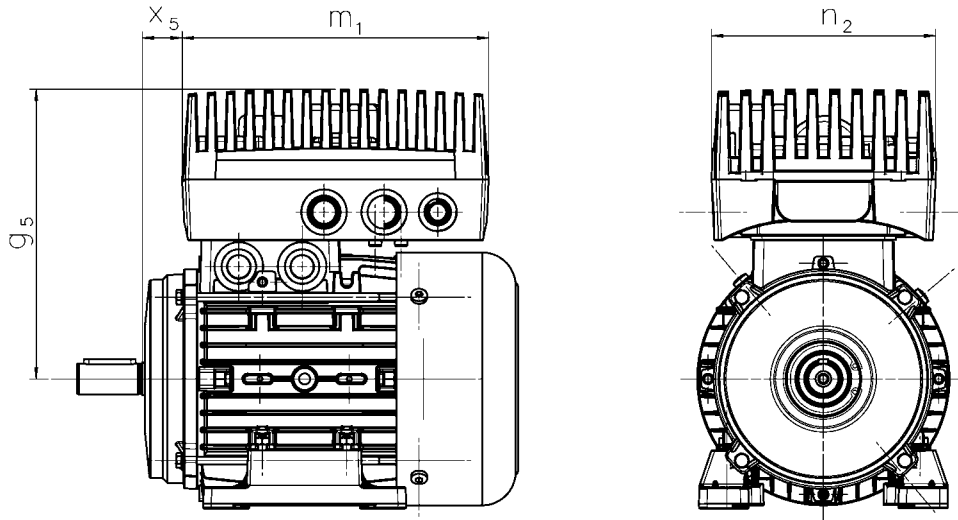

Product key						
Motor		Inverter				
		$g_5$	$x_5$	$m_1$	$n_2$	
		[mm]	[mm]	[mm]	[mm]	
MD□MA□□063-12		E82MV551_4B	216	16	202	156
MD□MA□□063-32						
MD□MA□□063-42						
MD□MA□□071-12		E82MV751_4B	228	20		
MD□MA□□071-32						
MD□MA□□071-42						
MD□MA□□080-12	MH□MA□□080-32	E82MV152_4B	239	29	230	176
MD□MA□□080-32						
MD□MA□□080-42						
MD□MA□□090-12	MH□MA□□090-12	E82MV222_4B	244	33		
MD□MA□□090-32	MH□MA□□090-32	E82MV302_4B	260	7		
MD□MA□□100-12	MH□MA□□100-12	E82MV402_4B	271	14	325	211
MD□MA□□100-32	MH□MA□□100-32	E82MV552_4B	271	14		
MD□MA□□112-22	MH□MA□□112-22	E82MV752_4B	281	16		



### MD□MA (IE1)

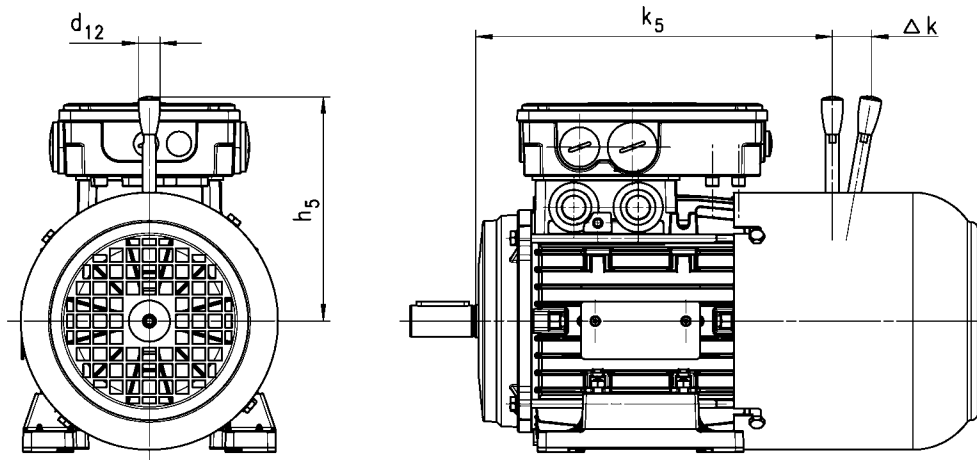

		Brake			
		$k_5$	$\Delta k$	$h_5$	$d_{12}$
		[mm]	[mm]	[mm]	[mm]
063	06	178	29	107	13.0
	08	206	27	116	13.0
071	06	205	29	107	13.0
	08	224	27	116	13.0
080	10	239	28	132	13.0
	08	238	27	116	13.0
090	10	251	28	132	13.0
	12	305	28	132	13.0
100	12	307	37	161	13.0
	14	320	37	161	13.0
112	14	323	41	195	24.0
	16	400	41	195	24.0
132	16	406	55	240	24.0
	18	505	55	240	24.0
160	18	509	59	279	24.0
	20	540	59	279	24.0
180	20	546	74	319	24.0

The following combinations with the manual release lever and motor connection in the same position are not possible:

- ▶ HAN connector with connection in position 1
- ▶ motec inverter
- ▶ Terminal boxes for motor sizes 071, 080, 090 for brake and feedback (M□□MA BR/BS/BA/BI)

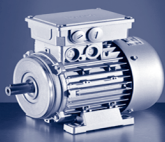

## Dimensions

Brake motor with manual release lever

### MH□MA (IE2)

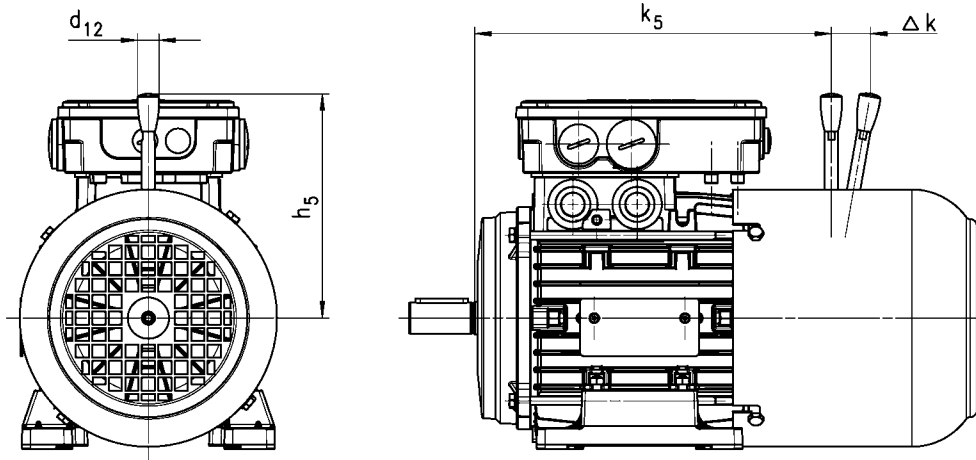

		Brake			
		$k_5$	$\Delta k$	$h_5$	$d_{12}$
		[mm]	[mm]	[mm]	[mm]
080	08	224	27	116	13.0
	10	239	28	132	13.0
090	08	264	27	116	13.0
	10	277	28	132	13.0
100 <sup>1)</sup>	10	305	28	132	13.0
	12	307	37	161	13.0
100 <sup>2)</sup>	10	320	28	132	13.0
	12	322	37	161	13.0
112	12	320	37	161	13.0
	14	323	41	195	24.0
132	14	400	41	195	24.0
	16	406	55	240	24.0
160	16	505	55	240	24.0
	18	509	59	279	24.0
180	18	540	59	279	24.0
	20	546	74	319	24.0
200	18	597	59	279	24.0
	20	603	74	319	24.0

<sup>1)</sup> 100-12

<sup>2)</sup> 100-32

The following combinations with the manual release lever and motor connection in the same position are not possible:

- ▶ HAN connector with connection in position 1
- ▶ motec inverter
- ▶ Terminal boxes for motor sizes , 080, 090 for brake and feedback (M□□MA BR/BS/BA/BI)

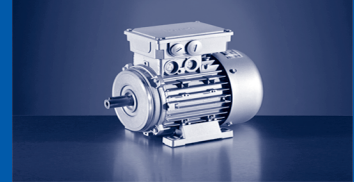

For optimum protection of three-phase AC motors against ambient conditions, the surface and corrosion protection system (OKS) offers tailor-made solutions.

Various surface coatings ensure that the motors operate reliably even at high air humidity, in outdoor installation or in the presence of atmospheric impurities. Any colour from the RAL Classic collection can be chosen for the top coat. The three-phase AC motors are also available unpainted (no surface and corrosion protection).

## OKS-G (primed)

### Applications

- ▶ Dependent on subsequent top coat applied

### Measures

- ▶ One-component priming coat (grey)

## OKS-S

### Applications

- ▶ Standard applications
- ▶ Indoor installation in heated buildings
- ▶ Air humidity up to 90%

### Measures

- ▶ Surface coating in accordance with corrosivity class C1 (in accordance with EN 12944-2)

## OKS-M

### Applications

- ▶ Indoor installation in unheated buildings
- ▶ Outdoor installation in covered, protected area
- ▶ Air humidity up to 95 %

### Measures

- ▶ Surface coating in accordance with corrosivity class C2 (in accordance with EN 12944-2)

## OKS-L

### Applications

- ▶ Outdoor installation
- ▶ Air humidity over 95%
- ▶ Chemical industrial plants
- ▶ Food industry

### Measures

- ▶ Surface coating complies with corrosivity class C3 (in accordance with EN 12944-2)
- ▶ Additional priming coat on fan cover and B-end shield
- ▶ Galvanised bolts
- ▶ Cable glands with sealing rings
- ▶ Corrosion-resistant brake with seal, non-rusting friction plate and chrome-plated armature plate (on request)

### Optional measures

- ▶ Sealed recesses on motor (on request)

A blower cannot be used in combination with OKS-L.

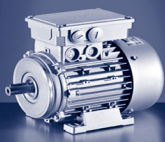

## Structure of surface coating

Surface and corrosion protection system	Without	OKS-G	OKS-S	OKS-M	OKS-L
Corrosivity category according to DIN EN ISO			C1	C2	C3
Structure of the surface coating					
1K primer					
2K-EP primer					
2K-PUR top coat					
Colour		Grey	Standard: RAL 7012 Optional: According to RAL Classic		