

Spring-applied brake **INTORQ BFK458**

The versatile modular system
1.5 – 600 Nm



INTORQ



BFK458 – The modular system

This modular system forms the basis for a product range that offers versions tailored for almost any task. The BFK458 spring-applied brake, as a standard product, can be used anywhere, but its modular structure also meets the requirements of specific industries. Its strength lies in its versatility.

Electromagnetically released spring-applied brakes are used wherever masses in motion have to be decelerated as quickly as possible or where masses must be held in a defined position. The braking force is applied by compression springs. Thus the braking torque generated by friction locking remains available in the de-energised status – even in the event of mains failure. The brake is released electromagnetically.

The BFK458 range replaces the 14.448/14.449 and 14.450 models of spring-applied brake. The main components of the modular system are the two basic modules E (adjustable braking torque) and N (braking torque not adjustable).

The greatest degree of flexibility is achieved for a broad range of applications by combining the basic module with specific modules. This catalogue is intended to help you to select and to order the spring-applied brake you require quickly and easily.

The modular system for all applications

- Brake motors
- Materials handling technology
- Cranes
- Storage technology
- Industrial trucks
- Wood working machines
- Stage machinery
- Vehicles for the disabled
- Automation technology
- Regulated drives
- Gate drives
- Escalators

LongLife design – BFK458-L

In high-cycle applications, spring-applied brakes are subject to two kinds of stress. Due to the large number of load alternations, the service life of the brake is determined both by the mechanical components of the brake itself and the useful life of the rotor, which is based on friction energy. In particular, the rotor/hub connection, the springs and the sleeve bolts are subject to wear due to the number of load cycles.

Based on the components mentioned, without additional measures the service life of spring-applied brakes is limited to 1×10^6 to 4×10^6 load cycles depending on the load.

The new LongLife design guarantees a service life of the brake mechanism of at least 10×10^6 switching cycles.



Cold climate version CCV – BFK458 with extended temperature range

Our brakes have been in use for many years in wind power plants, carrying out their duties reliably. So that they are equipped to face future challenges, the temperature range for the spring-applied brakes in the BFK458 series has been extended and the necessary modules have been added to the modular system. As a result, the brakes can be used in a range from -40°C to $+40^{\circ}\text{C}$.

CCV components essential for use to -40°C :

- Chrome-plated armature plate, chrome-plated flange
- Temperature-resistant fixing screws

CCV components (optional), approved for the use to -40°C

- Rotor with sleeve (noise-reduced)
- Manual release
- Terminal box
- Microswitch
- Caps E and N
- Shaft sealing rings

Features

- CCV design for all sizes (06-25)
- Fully functional to -40°C
- Mechanical strength of the components to -40°C
- Configurable thanks to an extended modular system
- available in small quantities

Application areas

- Wind power plants
- Cold storage houses
- Materials handling technology
- Industrial trucks



INTORQ BFK458-□□□ product key

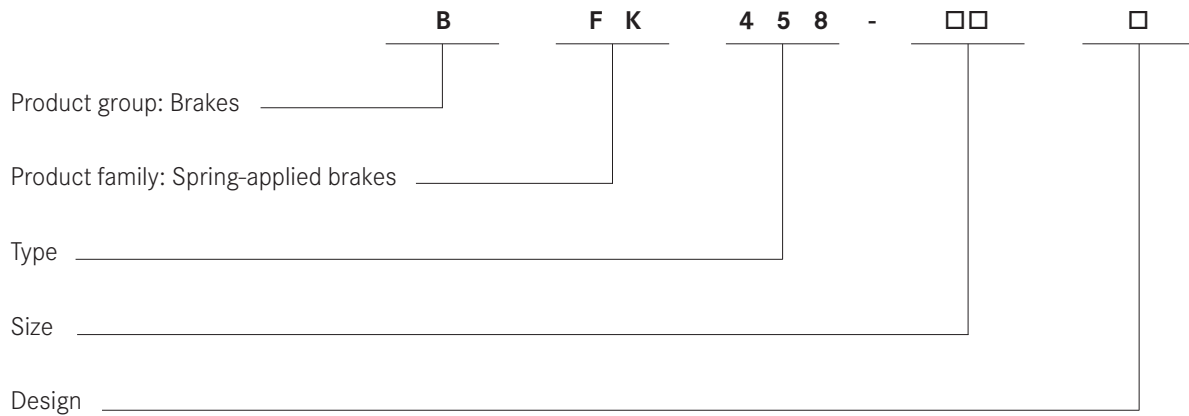

Size

06, 08, 10, 12, 14, 16, 18, 20, 25

Not coded:

Supply voltage, hub bore, options

Stator design

E – Adjustable (braking torque can be reduced using torque adjustment ring)

N – Non-adjustable

L – Non-adjustable, LongLife design

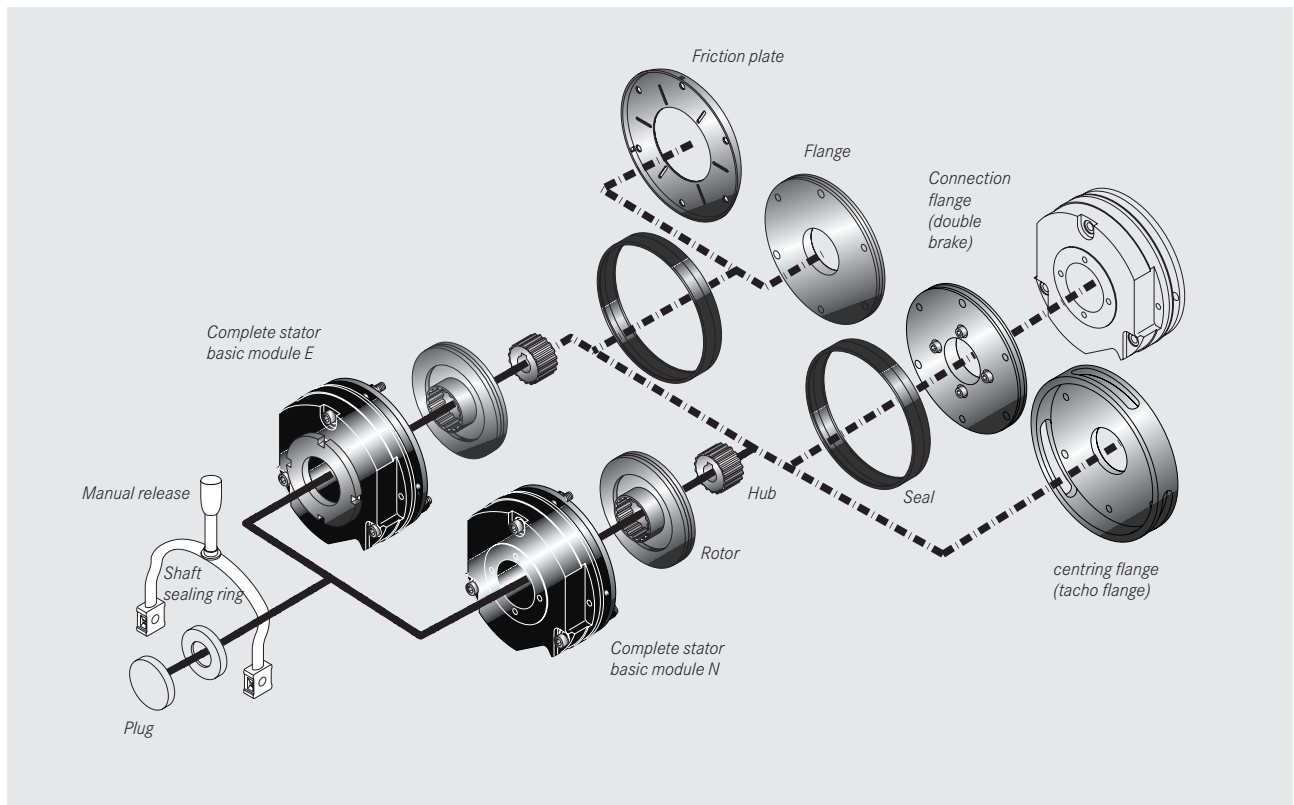

Contents

Product key	4	Microswitch	18
List of abbreviations	5	Terminal box	19
Product information	6	Type code	20
Principle of operation	7	Bridge rectifiers and BEG half-wave rectifiers	
Example applications	8	Spark suppressor INTORQ 14.198.00 □	20
Technical data		Bridge rectifiers and BEG half-wave rectifiers	22
Braking torques	9	Fastening options	25
Basic module E/N +	10	Connection diagrams	26
Flange + manual release		Supply voltage selection table	27
Basic module N + centring flange	11	Selection	
Basic module N +	12	Basic information	28
Connection flange + basic module N		Calculation example	29
Rated data	13	Overview	30
Operating times	14		
Service life and wear	15		
Accessories			
Manual release/flange/friction plate	16		
Centring flange/connection flange/ cover ring/brake cover	17		

List of abbreviations

P	[kW]	Drive power	t₁₁	[s]	Delay time (time from disconnecting the voltage until the torque begins to rise)
M_K	[Nm]	Characteristic torque of brake	t₁₂	[s]	Rise time of braking torque
M_L	[Nm]	Load torque	K		Safety factor
M_{req}	[Nm]	Required braking torque	Q	[J]	Calculated friction energy per switching cycle
M_a	[Nm]	Deceleration torque	Q_{perm}	[J]	Max. permissible friction energy per switching cycle
Δn₀	[rpm]	Initial relative speed of the brake	S_h	[h ⁻¹]	Operating frequency, i.e the number of periodical brake operations
J_L	[kgm ²]	Moment of inertia of all driven parts, referred to the shaft to be braked	S_{lü}		Rated air gap
t₁	[s]	Engagement time, t ₁ = t ₁₁ + t ₁₂			
t₂	[s]	Disengagement time (time from the beginning of the torque drop until 0.1 M _K is reached)			
t₃	[s]	Slipping time (time during which relative motion occurs between input and output, with the brake applied)			



Product information

A powerful and complete range

- 9 sizes
- Standard voltages 24 V, 96 V, 103 V, 170 V, 180 V, 190 V, 205 V
- Graduated torque range from 1.5 - 600 Nm
- Short delivery times for the complete range thanks to optimised logistics
- IP54 enclosure, depending on the particular operating conditions
- ATEX:
The product is suitable for use in potentially explosive atmospheres in zone II for stationary operation (holding or parking brake), explosion group II and temperature class T4.

Versatile

- Modular structure for virtually all applications
- Interchangeable with brake models 14.448 and 14.450

Torque transmission

- Designed for dry running

Quick and easy mounting

- Preset air gap
- Special machining of the friction surfaces ensures that the characteristics are achieved after very few switching operations
- No fixed bearing is required on the brake

Durable

- The insulation system to temperature class F (155°C) ensures that the winding has a long service life
- The brakes are designed for 100% duty time (current applied to the brake)

Low maintenance

- Long rotor/hub connection with low rate of wear and a tried-and-tested involute gear
- Asbestos-free friction linings with low rate of wear

Reliable

- The certified ISO 9001 and ISO 14001 quality system provides the basis for consistently high-quality products
- Production and testing to VDE 0580

Options

- Manual release for all sizes, both directions can be used for release and mounting (one exception is the tacho brake)
- Noise-reduced design
- Various types of corrosion protection and enclosures
- Microswitches used to monitor air gap and wear (size 12 and above)
- Monitoring of manual release function (page 19)
- Non-standard voltages and bores on request

LongLife design – BFK458-L

- Armature plate with low backlash and reinforced torque support
- Compression springs with guide pins for protection against shearing forces
- Aluminium rotor with toothed intermediate ring: Both the friction lining and the tooth system have a low rate of wear

Temperature resistant to -40 °C

- Use of chrome-plated friction surfaces (armature plate and flange)
- Use of temperature-resistant fixing screws is essential
- Can also be combined with the noise-reduced rotor

 to -40°C

Principle of operation

Basic module E

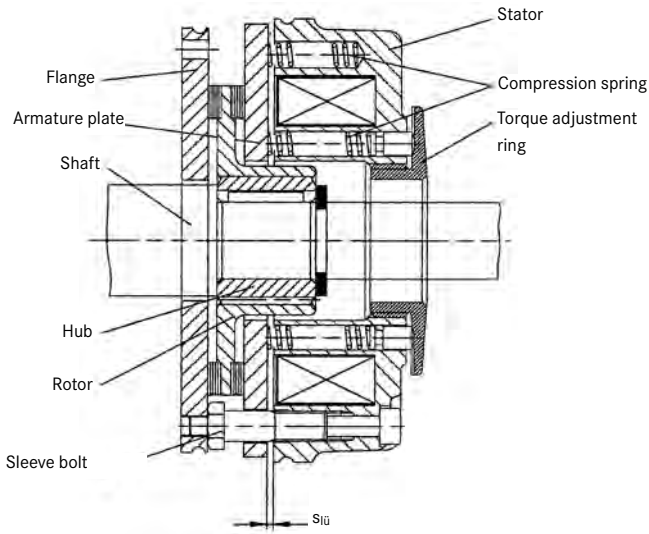

Basic module N

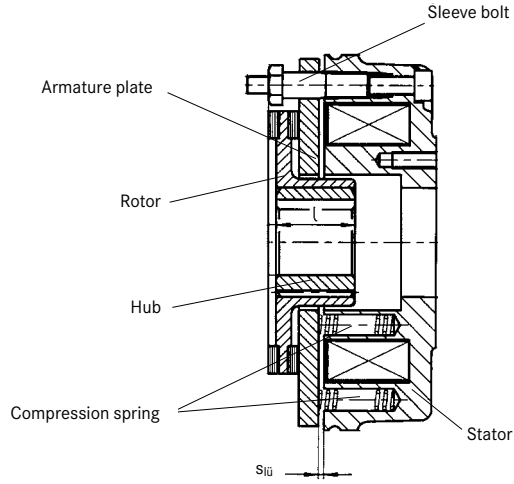

INTORQ BFK458 spring-applied brakes are single-disc brakes with two friction surfaces. When de-energised, several compression springs are used to generate the braking torque through friction locking. The brake is released electromagnetically. During the braking procedure, the compression springs push the rotor, which can be shifted axially on the hub, against the counter friction face via the armature plate. When the brakes are applied, an air gap $slü$ is present between the armature plate and the stator. The stator's coil is energised with DC voltage in order to release the brake.

The resulting magnetic flux works against the spring force to draw the armature plate to the stator. This releases the rotor from the spring force and allows it to rotate freely. Basic module E supports the use of the torque adjustment ring to reduce the braking torque.

BFK458 noise-reduced



BFK458 corrosion-resistant



BFK458-L LongLife



Example applications

Wind power plants



Theatre technics



Cranes



Technical data

Braking torques

Basic modules E and N are available with the torque ratings listed below. At low torques, an intermediate plate (brass sheet) needs to be inserted between the stator and armature plate in order to achieve short operating times. INTORQ brakes are designed to ensure the specified characteristic torques are usually achieved after a short running-in period. However, as the characteristics of the organic friction linings used and the environmental conditions may vary, the braking torques specified may be subject to some deviation. Appropriate

safety features should be considered at design stage to deal with these issues. In particular, humidity and fluctuating temperatures after long periods of downtime may lead to a higher level of breakaway torque. The braking torque needs to be checked if the brake is being used against friction surfaces at customer premises. If the brake is only being used as a holding brake without any dynamic load, the friction lining must be reactivated at regular intervals.

Size	06	08	10	12	14	16	18	20	25
Characteristic torques [Nm], related to the relative speed $\Delta n = 100$ rpm								80E	
	1.5 E	3.5 N/E			25 N/E	35 N/E	65 N/E	115 N/E	175 N/E
	2 N/E	4 E	7 N/E	14 N/E	35 N	45 N/E	80 N/E	145 N/E	220 N
	2.5 N/E	5 N/E	9 N/E	18 N/E	40 N/E	55 N/E	100 N/E	170 N/E	265 N/E
	3 N/E	6 N/E	11 N/E	23 N/E	45 N/E	60 N/E	115 N/E	200 N/E	300 N/E
	3.5 N/E	7 N/E	14 N/E	27 N/E	55 N/E	70 N/E	130 N/E	230 N/E	350 N/E
	4 N/E	8 N/E	16 N/E	32 N/E	60 N/E	80 N/E	150 N/E	260 N/E	400 N/E
	4.5 N/E	9 N/E	18 N/E	36 N/E	65 N/E	90 N/E	165 N/E	290 N/E	445 N/E
	5 E	10 E	20 E	40 E	75 N/E	100 N/E	185 N/E	315 N/E	490 N/E
	5.5 E	11 E	23 N/E	46 N/E	80 N/E	105 N/E	200 N/E	345 N/E	530 N/E
	6 N/E	12 N/E				125 N/E	235 N/E	400 N/E	600 N/E

- N ... Braking torque for design N (without torque adjustment ring)
- E ... Braking torque for design E (with torque adjustment ring)

Service brake
($S_{\text{ümax}}$ approx. $2.5 \times S_{\text{ij}}$)

Standard braking torque

Holding brake with emergency stop
($S_{\text{ümax}}$ approx. $1.5 \times S_{\text{ij}}$)

LongLife BFK458-L

- Sizes 06, 08, 10, 12
- Stator corresponds to "N design", same dimensions
- Braking torques up to standard torque available according to the catalogue
- Low braking torques can be configured even without pole shim
- Microswitches not configurable
- Bore holes and built-on accessories on the rear not possible

Basic module E, reduced braking torque

The braking torque on basic module E can be reduced using the torque adjustment ring located in the stator. The torque adjustment ring can be unscrewed to a maximum dimension of $h_{1\text{max}}$ (see table on page 10).

It should be noted that the engagement and disengagement times change in accordance with the braking torque. Torque reduction is independent of the characteristic used.

Size	06	08	10	12	14	16	18	20	25
Torque reduction per detent position [Nm]	0.2	0.35	0.8	1.3	1.7	1.6	3.6	5.6	6.2

Technical data

Basic module E/N + flange + manual release

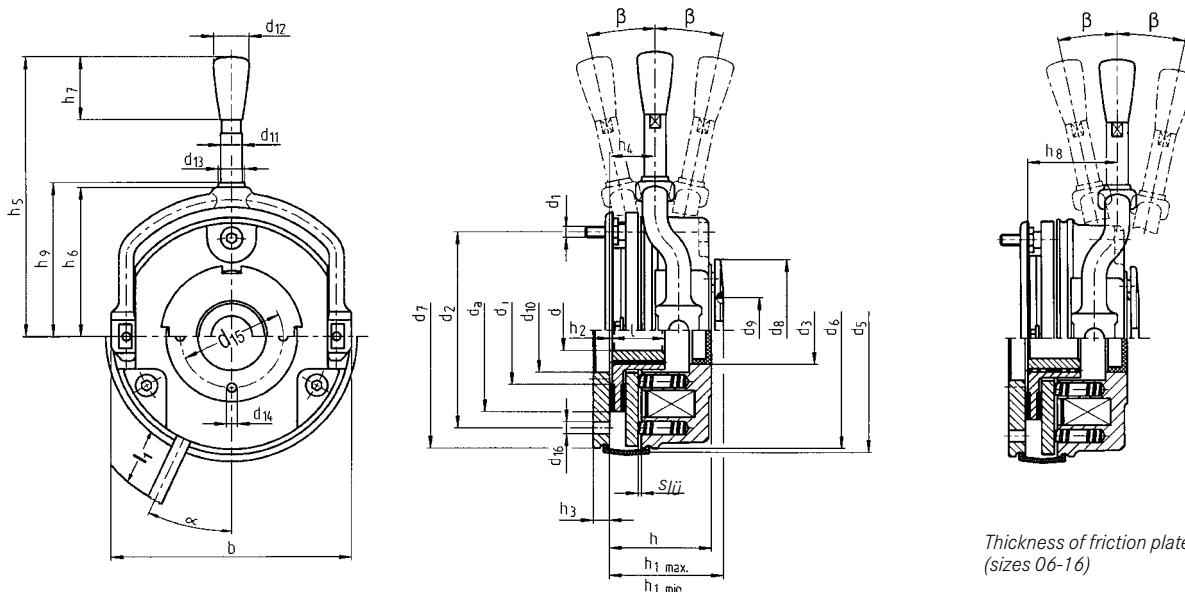

Thickness of friction plate: 1.5 mm (sizes 06-16)

Size	b	d ₁ ¹⁾ spec.	d ₂ ²⁾ standard	d ₃	d ₄	d ₅ ^{H7}	d ₆	d ₇	d ₈	d ₉ ^{H8}	d ₁₀	d ₁₁	d ₁₂	d ₁₃	d ₁₄ ³⁾	d ₁₅ ³⁾	d ₁₆	d _i	d _a	
06	88	10	10/11/12/14/15	3xM4	72	25	91	87	87	52	24	31	8	13	9.6	4xM4	37.7	3x4.5	40	60
08	106.5	10	11/12/14/15/20	3xM5	90	32	109	105	105	60	26	41	8	13	9.6	4xM5	49	3x5.5	47	77
10	132	10	11/12/14/15/20	3xM6	112	42	134	130	130	68	35	45	10	13	12	4xM5	54	3x6.6	66	95
12	152	14	20/25	3xM6	132	50	155	150	150	82	40	52	10	13	12	4xM5	64	3x6.6	70	115
14	169	14	20/25/30	3xM8	145	60	169	165	165	92	52	55	12	24	14	4xM6	75	3x9	80	124
16	194.5	15	25/30/35/38*	3xM8	170	68	195	190	190	102	52	70	12	24	14	4xM6	85	3x9	104	149
18	222	20	30/35/40/45	6xM8	196	75	222	217	217	116	62	77	14	24	15.5	4xM8	95	4x9 ⁴⁾	129	174
20	258	25	35/40/45/50	6xM10	230	85	259	254	254	135	72	90	14	24	16.5	4xM10	110	4x11 ⁴⁾	148	206
25	302	30	40/45/50/55/60/65/70*	6xM10	278	115	307	302	302	165	85	120	16	24	18.4	4xM10	140	6x11	199	254

- 1) Pre-drilled without keyway
- 2) Standard keyway in accordance with DIN 6885/1 P9, selection of the shaft diameter dependent upon type of load (see the operating instructions)
- * Ø 38 and Ø 70 mm, keyway in accordance with DIN 6885/3 P9
- 3) Bores are made on customer request for sizes 6 - 12
- 4) The thread in the mounting surface is offset by 30° in relation to the centre axis of the manual release lever
- Dimensions in mm

Size	h	h ₁ min.	h ₁ max.	h ₂	h ₃	h ₄	h ₅ standard	h ₅ ⁷⁾ max.	h ₆	h ₇	h ₈	h ₉	l	l ₁ ⁵⁾	s _{li}	a	b ⁶⁾
06	36.3	39.3	43.25	1	6	15.8	107-	-	54.5	23	32.8	56.3	18	400	0.2	25°	12°
08	42.8	46.8	50.8	1.5	7	16.3	116	-	63	23	41.3	65	20	400	0.2	25°	10°
10	48.4	52.4	55.9	2	9	27.4	132	-	73.8	23	42.4	77.8	20	400	0.2	25°	9°
12	54.9	58.9	67.53	2	9	29.4	161	-	85	23	47.4	88.5	25	400	0.3	25°	10°
14	66.3	71.3	77.3	2	11	33	195	-	98	32	50	101.5	30	400	0.3	25°	9°
16	72.5	77.5	85.5	2.25	11	37.5	240	-	113	32	53.5	116	30	600	0.3	25°	10°
18	83.1	89.1	97.09	2.75	11	41.1	279	394	124	32	59.1	128.5	35	600	0.4	25°	9°
20	97.6	104.6	114.6	3.5	11	47.6	319	416	146	32	68.6	149.5	40	600	0.4	25°	10°
25	106.7	115.7	127.7	4.5	12.5	57.7	445	501	170	32	88.7	175.5	50	600	0.5	25°	10°

- 5) Length of the connecting cable
- 6) Manual release angle tolerance +3°
- 7) Recommended lever length for 1.5 Mk
- Recommended ISO shaft tolerances: up to Ø 50 mm = k6
over Ø 50 mm = m6

Technical data

Basic module N + centring flange

Brake suitable for mounting a speed or angle sensor

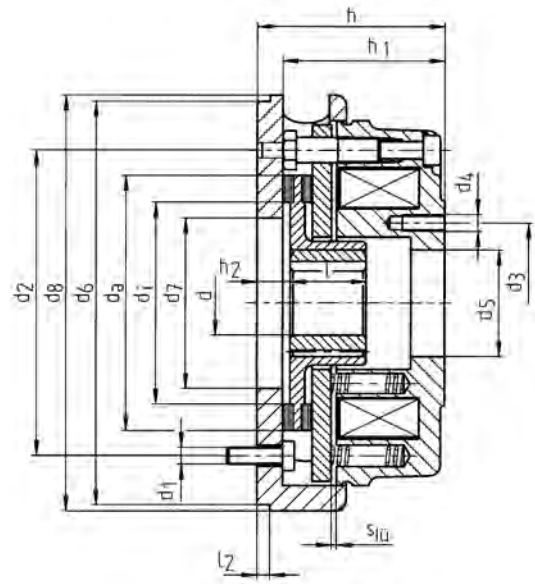

Size	h	h ₁	h ₂	d ^{H7} max.	d ₁ ¹⁾	d ₂	d ₃	d ₄ ⁵⁾	d ₅ ^{H7}	d ₆ ^{H7}	d ₇ ^{H7}	d ₈	d _i	d _a	l	l ₁ ²⁾	l ₂	s ₁
06	42.3	36.3	7	15	3xM4	72	37.7	4xM4	25	95	40	98	40	60	18	400	2	0.2
08	49.8	42.8	8.5	20	3xM5	90	49	4xM5	32	115	50	116	47	77	20	400	2	0.2
10	57.4	48.4	11	20	3xM6	112	54	4xM5	42	140	60	141	66	95	20	400	2	0.2
12	63.9	54.9	11	25	3xM6	132	64	4xM5	50	162	60	165	70	115	25	400	2	0.3
14	76.5	65.5	13	30	3xM8	145	75	4xM6	60	177	80	181	80	124	30	400	2	0.3
16	83.5	72.5	13.25	38 ⁴⁾	3xM8	170	85	4xM6	68	204	85	206	104	149	30	600	2	0.3
18	94.1	83.1	13.75	45	6xM8	196	95	4xM8	75	233	90	237	129	174	35	600	2	0.4
20	108.6	97.6	14.5	50	6xM10	230	110	4xM10	85	271	90	274	148	206	40	600	2	0.4
25	118.2	106.7	17	70 ⁴⁾	6xM10	278	140	4xM10	115	322	120	324	199	254	50	600	2	0.5

¹⁾ Use DIN 6912 fixing screws

²⁾ Cable length

³⁾ Manual release can be mounted as an option, as shown on the right of page 10

⁴⁾ Keyway in accordance with DIN 6885/3-P9

⁵⁾ Bores are made on customer request for sizes 06 - 12

Dimensions in mm



Technical data

Basic module N + connection flange + basic module N

Double brake (double braking torque) as redundant braking system, suitable for use in stage machinery and many other areas of application

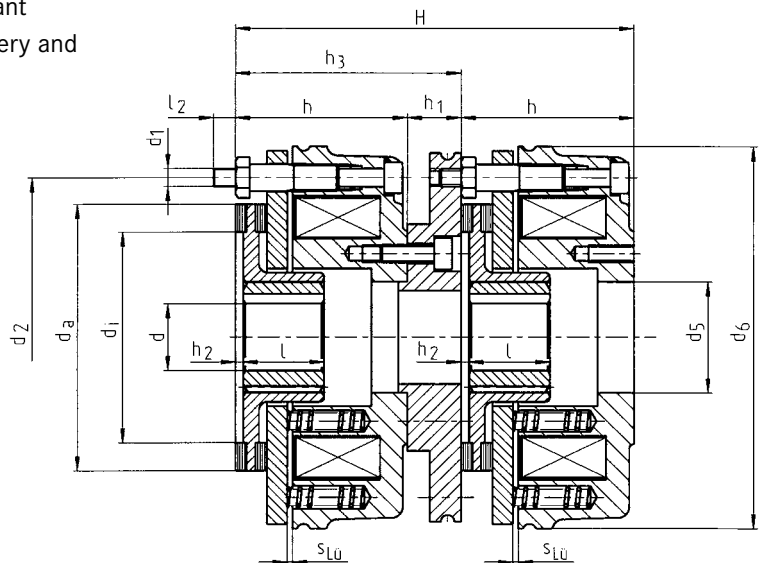

Size	d ^{H7}	d ₁	d ₂	d ₅ ^{H7 max.}	d _{6j7}	d _i	d _a	H	h	h ₁	h ₂	h ₃	l	l ₁ ¹⁾	l ₂	s _{LÜ}
06	15	3xM4	72	25	87	40	60	84.6	36.3	12	1	48.3	18	400	8.7	0.2
08	20	3xM5	90	32	105	47	77	97.6	42.8	12	1.5	54.8	20	400	9.8	0.2
10	20	3xM6	112	42	130	66	95	109.8	48.4	13	2	61.4	20	400	12.7	0.2
12	25	3xM6	132	50	150	70	115	125.8	54.9	16	2	70.9	25	400	13.1	0.3
14	30	3xM8	145	60	165	80	124	148	65.5	17	2	82.5	30	400	13.1	0.3
16	38 ²⁾	3xM8	170	68	190	104	149	165	72.5	20	2.25	92.5	30	600	16.4	0.3
18	45	6xM8	196	75	217	129	174	186.2	83.1	20	2.75	103.1	35	600	17.5	0.4
20	50	6xM10	230	85	254	148	206	215.2	97.6	20	3.5	117.6	40	600	17.8	0.4
25	70	6xM10	278	115	302	199	254	238.4	106.7	25	4.5	130.7	50	600	21.5	0.5

■ ¹⁾ Cable length

■ ²⁾ Keyway in accordance with DIN 6885/3-P9

■ Manual release as an option

■ Dimensions in mm

Noise-reduced designs

The noise reduction required in many applications can be achieved in two ways:

1. Impact-noise-reduced armature plate

The brake's operating noise can be minimised using special damping elements, which are installed between the pole face and the armature plate as shock absorbers.

2. Noise-reduced aluminium rotor

The rotor with plastic sleeve boasts numerous advantages and reduces the rattling noises which can occur in the rotor/hub connection. The involute gear, which has been proving its worth in practical applications for many years, stabilises the rotor/hub connection. The plastic sleeve reduces the backlash, thereby increasing the service life of the brake.

Features and advantages

- Low-backlash power transmission between shaft and rotor
- High service life thanks to involute gear and long rotor neck
- Low rate of wear between rotor and hub thanks to low backlash
- Recommended for frequency inverter operation
- Noise-reduced design



Technical data

Rated data

Size	P ¹⁾ [20 °C]	S _ü max service brake	S _ü max holding brake	max. adjustment	min. ² rotor thickness	J plastic rotor	J aluminium rotor	mass stator assy [kg]
	[W]	[mm]	[mm]	[mm]	[mm]	[kgcm ²]	[kgcm ²]	
06	20	0.5	0.3	1.5	4.5	0.11	0.15	0.75
08	25	0.5	0.3	1.5	5.5	0.34	0.61	1.2
10	30	0.5	0.3	1.5	7.5	-	2.0	2.1
12	40	0.75	0.45	2.0	8.0	-	4.5	3.5
14	50	0.75	0.45	2.5	7.5	-	6.3	5.2
16	55	0.75	0.45	3.5	8.0	-	15	7.9
18	85	1.0	0.6	3.0	10.0	-	29	12
20	100	1.0	0.6	4.0	12.0	-	73	19.3
25	110	1.25	0.75	4.5	15.5	-	200	29.1

■ 1) Coil power at 20°C in W, possible deviation up to +10%, depending on supply voltage selected.

■ 2) The friction lining is dimensioned so that the brake can be readjusted at least five times.

Braking torques, depending on speed and permissible limit speeds

Size	Average Braking torque on braking from Δn ₀ to standstill [%]	Braking torque at Δn ₀ [rpm] [%]			Max. speed Δn _{0max} [rpm]
		1500	3000	max.	
06	100	87	80	74	6000
08	100	85	78	73	5000
10	100	83	76	73	4000
12	100	81	74	73	3600
14	100	80	73	72	3600
16	100	79	72	70	3600
18	100	77	70	68	3600
20	100	75	68	66	3600
25	100	73	66	66	3000

As speed increases, so does wear.



Technical data

Operating times

The listed operating times apply to DC switching with rated air gap $s_{l\ddot{u}}$ and a warm coil. The times are mean values which may vary depending on the method of rectification

and the air gap $s_{l\ddot{u}}$. The engagement time t_1 is approximately 10 times higher for AC switching than for DC switching.

Torque time characteristic, dependent on excitation voltage

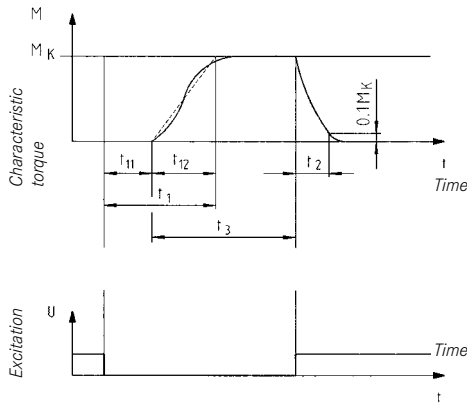

- t_{11} = Delay time
- t_{12} = Rise time of braking torque
- t_1 = Engagement time
- t_2 = Disengagement time
- t_3 = Slipping time

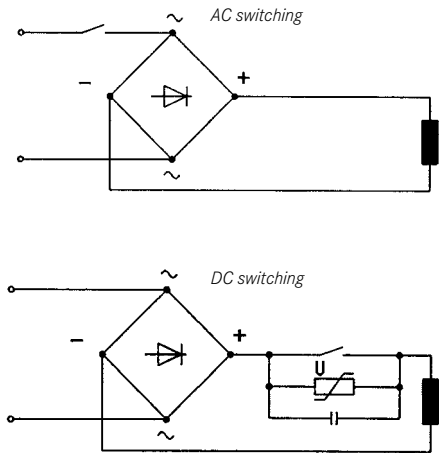

Size	Braking torque rating at $\Delta n = 100 \text{ rpm}^{-1}$ M_K ¹⁾ [Nm]	Maximum permissible switching energy for single switching operation Q_E [J]	Transitional switching frequency S_h [h ⁻¹]	Operating times [ms] ²⁾ at $s_{l\ddot{u}}$			
				Connection on the DC side			Disconnect
				t_{11}	t_{12}	t_1	t_2
06	4	3000	79	15	13	28	45
08	8	7500	50	15	16	31	57
10	16	12,000	40	28	19	47	76
12	32	24,000	30	28	25	53	115
14	60	30,000	28	17	25	42	210
16	80	36,000	27	27	30	57	220
18	150	60,000	20	33	45	78	270
20	260	80,000	19	65	100	165	340
25	400	120,000	15	110	120	230	390

¹⁾ Minimum braking torque for run-in friction pairs

²⁾ Operating times valid for 205 V DC coils

Technical data

Service life and wear

The brake has to be adjusted when $s_{\text{liümax}}$ is reached. The friction energy to be withstood up to this point is dependent on a number of factors: in particular, the inertias to be braked, the braking speed, the operating frequency and the resulting temperature on the friction surfaces. For this reason, no universal value for all operating conditions can be given in respect of the amount of friction energy that can be handled before adjustment is required.

In addition, increased wear should be expected with vertical mounting.

The BFK458 can be adjusted when the maximum permissible working air gap is reached ($s_{\text{liümax}}$). The dimensioning of the friction lining allows adjustment to be carried out at least five times.

Where the amount of friction energy per switching operation is low, the brake's mechanical components can impose limitations in terms of service life. In particular, the rotor/hub connection, springs, armature plate and sleeves are subject to operational wear. The expected service life of the standard design is around 1 million load alternations. Solutions that are optimised in terms of service life are available in cases where a longer service life is required (consult the manufacturer).

Maintenance

Brakes are components which are subject to a great deal of wear. When installing the brake, it must be ensured that it can be easily accessed for inspection and maintenance purposes. Intervals between inspections should be set in accordance with the expected service life and load. For more information, please see the operating instructions.

Permissible friction energy Q_{perm} depending on operating frequency S_h

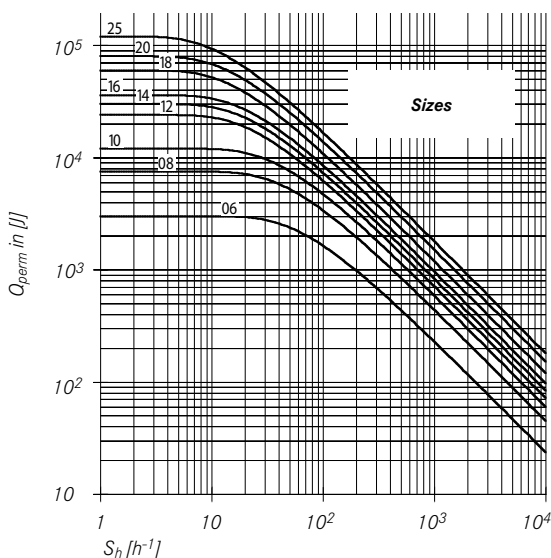

The values for the maximum permissible switching energy Q_E are reduced dependent upon the brake size and the operating speed as shown in the table on the left.

BFK458-L

Guaranteed performance data for the LongLife design

- Guaranteed service life of brake mechanism:
 - 10x10⁶ repetitive cycles of operation
 - 15x10⁶ reversing cycles of operation
- The brake warranty covers either two years or the guaranteed number of cycles – whichever is reached first.
- The scope of the warranty in the event of premature failure covers replacement of the brake, including a flat-rate replacement fee.

Accessories

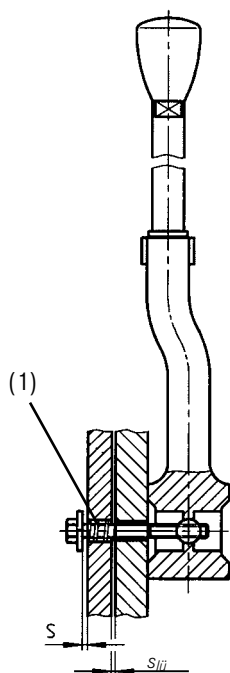

Manual release

The manual release is used to release the brake by hand and can be retrofitted. The manual release springs back to its base position automatically after operation (1). The manual release requires an additional air gap S in order to function; this is factory-set prior to delivery. Dimension S (see the mounting instructions) must be checked once the equipment has been mounted.

Size	$s_{10}^{+0.1}$ -0.05 [mm]	$s^{+0.1}$ [mm]
06 08 10	0.2	1
12 14 16	0.3	1.5
18 20	0.4	2
25	0.5	2.5



Flange



Friction plate
(sizes 06 - 16)

Flange

A flange can be used if no suitable counter friction face is available. The flange can also be fitted with a cover ring.

Friction plate

A friction plate is available for sizes 06 up to and including 16. This should be used if the counter face is smooth and machined, but is not suitable as a friction surface. The plate can be combined with a cover ring.

Centring flange (tacho brake)

Basic module N combined with a centring flange is suitable for mounting a tacho generator.



Centring flange



Connection
flange



Seal

Connection flange (double brake)

The connection flange can be used to adapt a second basic-module to basic module N; the resulting double brake is suitable for use in stage machinery or other applications with increased safety requirements.

Seal

To a large extent, the seal prevents the exit or ingress of dust, humidity, dirt, etc., out of or into the braking area. The seal is inserted into the groove on the stator. If no suitable groove is available on the counter friction face, we recommend the use of a flange or a friction plate.

Accessories

Brake cover

A cover can be mounted onto basic module E and basic module N as an option, to protect the brake from water and dust (enclosure to IP65). This design is not available in conjunction with manual release.

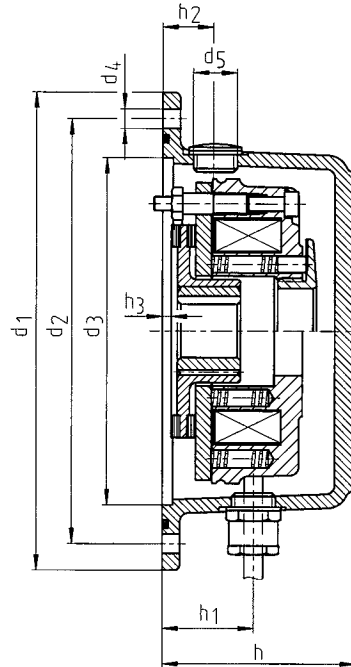

Size	d ₁	d ₂	d ₃ ^{H8}	d ₄	d ₅	h	h ₁	h ₂	h ₃ ¹⁾
06	135	120	98	4x4.5	M16x1.5	55	28	16.5	3
08	155	142	118	4x5.5	M20x1.5	61	34	20	3
10	185	166	143	4x5.5	M20x1.5	72	39	21	3
12	205	192	163	4x6.6	M20x1.5	82	42	23	3
14	225	212	183	4x6.6	M20x1.5	92	51	24	3
16	250	236	208	4x6.6	M20x1.5	98	52	25	3
18	285	268	238	4x6.6	M20x1.5	115	60	29	3
20	330	314	283	4x9	M20x1.5	131	69	35	3
25	390	368	328	4x9	M20x1.5	142	78	40	3

1) Recommended recess length on motor endshield

Accessories

Microswitch

The brake can be fitted with a microswitch for the purpose of monitoring the release or wear. The microswitch can be built into the circuit as an NC contact or an NO contact.

Mounting the microswitch onto basic module E

Dimensions

Size	12	14	16	18	20	25
Dimension x	13	11.5	11	7	*	*
Overall radius r	80.5	88.5	99	112.5	*	155

- * No projection
- Dimensions in mm

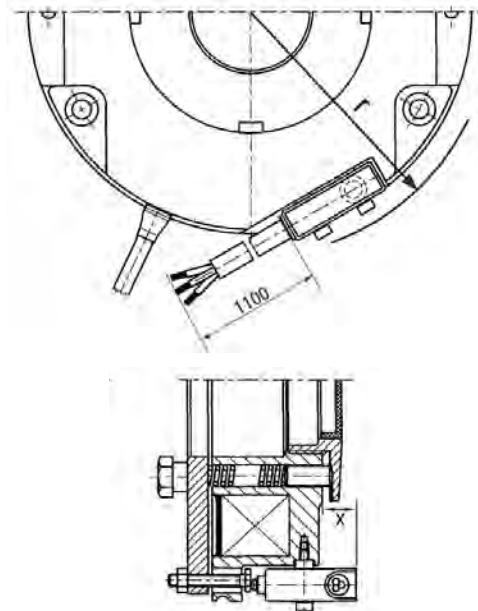

Microswitch for manual release monitoring

Gate drives, for instance, are provided with brakes with manual release, and a microswitch for monitoring the manual release. In this case, the manual release must make it possible to move the gate to the desired position in manual operation, e.g. using a crank. This manual operation has to be detected via a microswitch, whose switching signal must be combined with the motor control, so that the motor can be prevented from starting (thus also preventing any possible injury to the operator). The microswitch for manual release monitoring is a built-on option.

The fixing bracket is screwed onto the magnet housing or stator via the bores on the rear face. The fixing bracket enables a microswitch to be fastened to it. The two directions of release, towards and away from the motor, can be implemented by using different fixing brackets and microswitch settings.



Accessories

Terminal box

The connecting cables can easily be integrated into higher-level controls via the terminal box (brake sizes 12-25) in order to support different wiring options (total of 3 inputs/outputs). 2/4-pole terminal strips, half-wave and bridge rectifiers and a microswitch connection can be integrated into the terminal box.

The terminal box is mounted on the spring-applied brake using a fixing bracket and screws, as shown in the illustration. You can select the mounting angle according to your requirements by using the assembly kit.

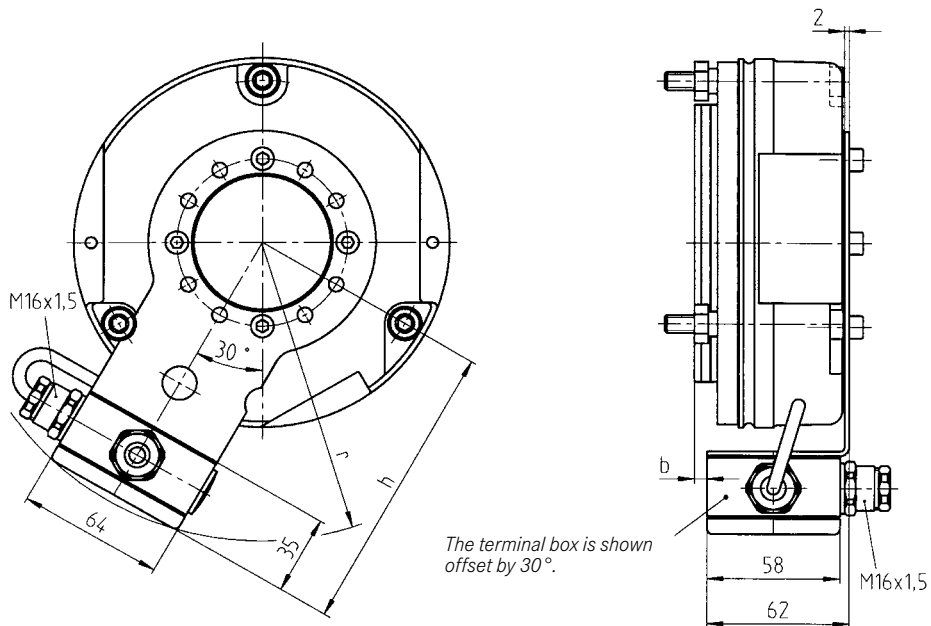

Size	12	14	16	18	20	25
b	-5	5.5	12.5	23	37.5	45.5
h	122	130	142	155	174	198
r	126	134	146	158.5	177	201

■ Dimensions in mm

Accessories

Bridge rectifiers and half-wave rectifiers

Type code	B	E	G	-	5	6	1	-	440
Brake _____									
Electronic _____									
Rectifier _____									
1 -Bridge rectifier _____									
2 -Half-wave rectifier _____									
5 -Bridge/half-wave rectifier _____									
4 -pole _____									
6 -pole _____									
1-Mounting position horizontal _____									
2-Mounting position vertical _____									
3-Mounting position horizontal with snap-in stud _____									
440 Voltage 440 V _____									

Universal spark suppressor INTORQ-14.198.00.0□

The universal spark suppressor limits the induced voltage arising when inductive direct current consumers are switched off on the DC side. These induced voltages can damage coils and switches. VDE 0580 therefore requires that, in order to avoid impermissibly

high switch-off voltages and overvoltages, suitable protective measures must be provided by the user. The universal spark suppressor is available in 4 versions for the following voltage ranges:

INTORQ	Coil voltage	Max. supply voltage	Max. coil power	Capacitor voltage	b ₁	b ₂ approx.	d	e approx.	h	l ₁	l ₂ approx.	m [g]
14.198.00.01	24 V - 50 V	60 V~	110 W	250 V-	8.5	12.5	0.7	22.5	18.5	26.5	25	7
14.198.00.02	50 V - 120 V	250 V~	110 W	630 V-	15	21	0.7	37.5	26	41.5	20	22
14.198.00.03	120 V - 200 V	400 V~	110 W	1000 V-	13	20	0.7	37.5	24	41.5	15	17
14.198.00.04	200 V - 250 V	555 V~	110 W	1000 V-	13	20	0.7	37.5	24	41.5	15	10

Dimensions

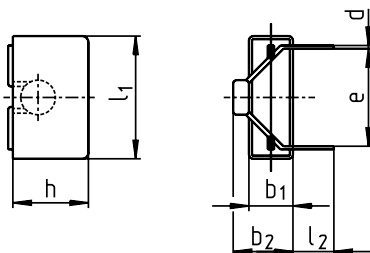

Wiring example

Parallel to contact

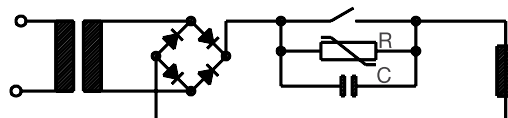

Parallel to coil

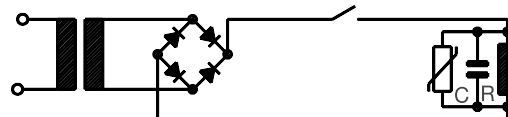

Accessories

4-pole bridge rectifiers and half-wave rectifiers

Dimensions

BEG-142/143-270
BEG-242/243-555

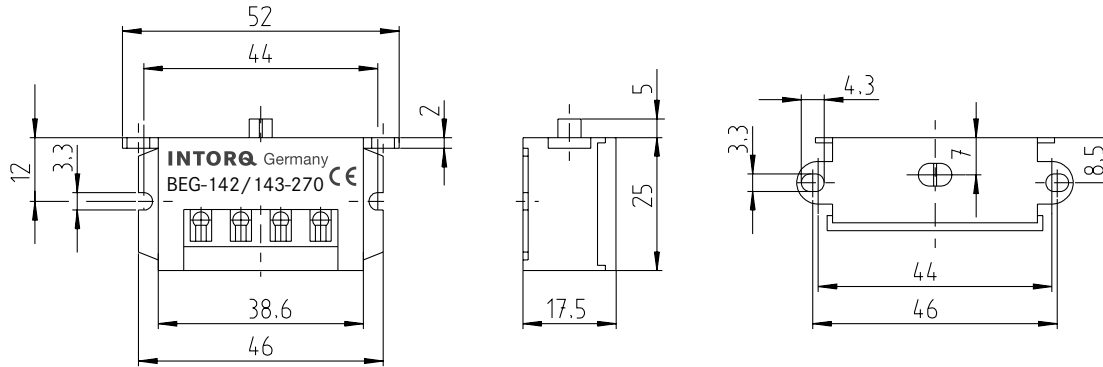

4-pole bridge rectifier

BEG-142-270
BEG-143-270

Application area

Current supply for spring-applied brakes from AC mains (normal excitation)
Example: 205 V coil on 230 V mains

Technical data

Max. supply voltage	270 V~
Max. DC current at 60°C	1.0 A
Max. ambient temperature	80°C

The rectifiers are protected against overvoltage by varistors in the input and output.

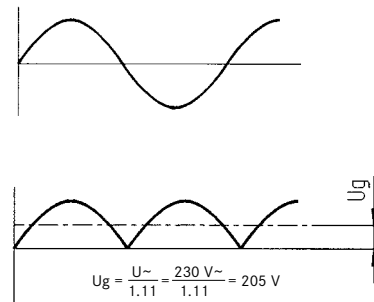

4-pole half-wave rectifier

BEG-242-555
BEG-243-555

Application area

Current supply for spring-applied brakes from AC mains (normal excitation)
Example: 180 V coil on 400 V mains

Technical data

Max. supply voltage	555 V~
Max. DC current at 60°C	1.0 A
Max. ambient temperature	80°C

The rectifiers are protected against overvoltage by varistors in the input and output.

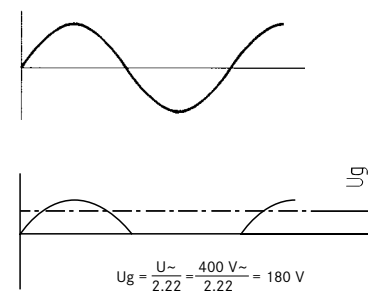

Accessories

6-pole bridge rectifier

Dimensions

BEG-162-270

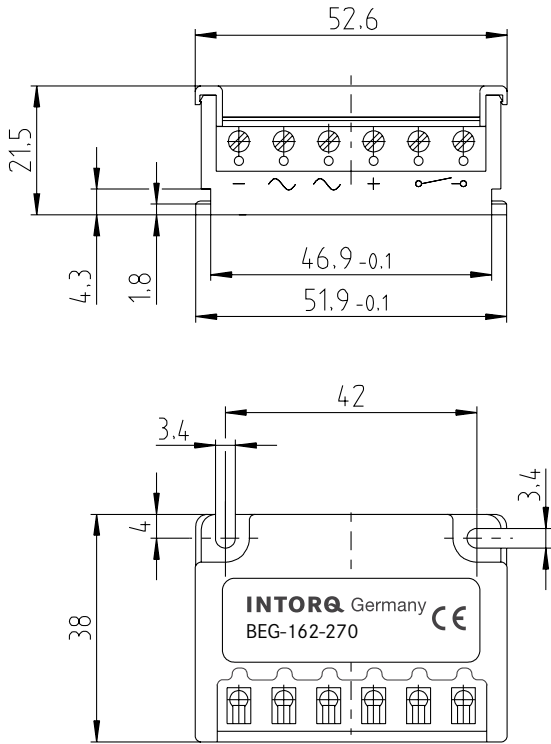

BEG-161-270

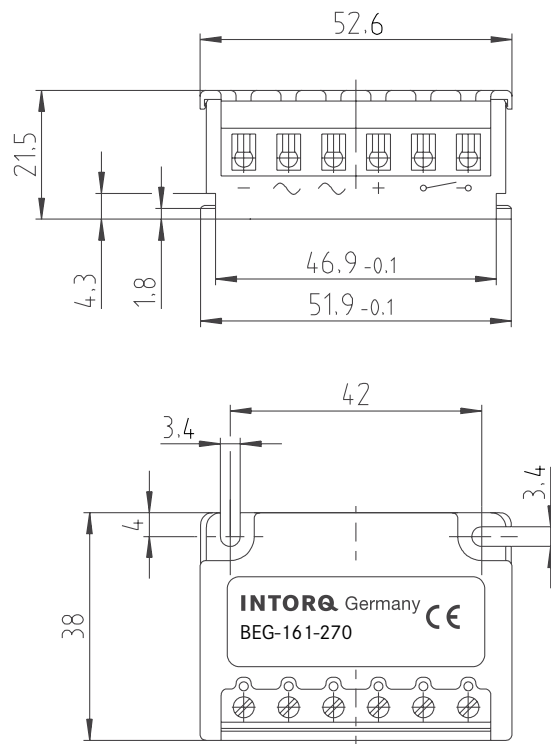

6-pole bridge rectifier

BEG-162-270

BEG-161-270

Application area

Current supply for spring-applied brakes from AC mains (normal excitation)

Example: 205 V coil on 230 V mains

Technical data

Max. supply voltage 270 V~

Max. DC current at 60°C 0.75 A

Max. ambient temperature 80°C

The rectifiers are protected against overvoltage by varistors in the input and output.

BEG-162-270/161-270/262-460/261-460 rectifiers also contain the spark suppressor required by VDE 0580 Section 26.

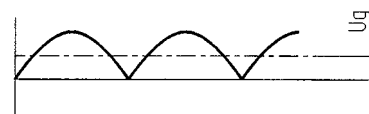
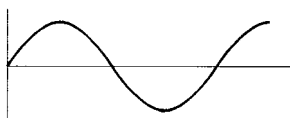

$$U_g = \frac{U_{\sim}}{1.11} = \frac{230 \text{ V}_{\sim}}{1.11} = 205 \text{ V}$$

Accessories

6-pole half-wave rectifier

Dimensions

BEG-262-460
BEG-262-555

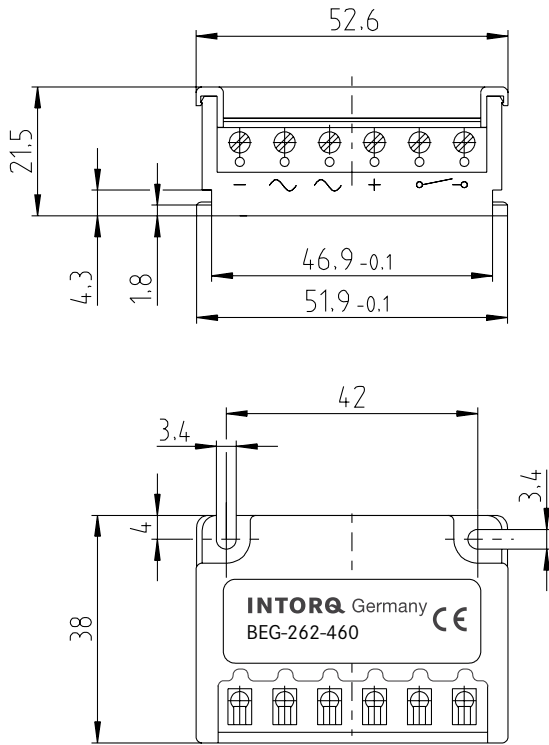

BEG-261-460
BEG-261-555

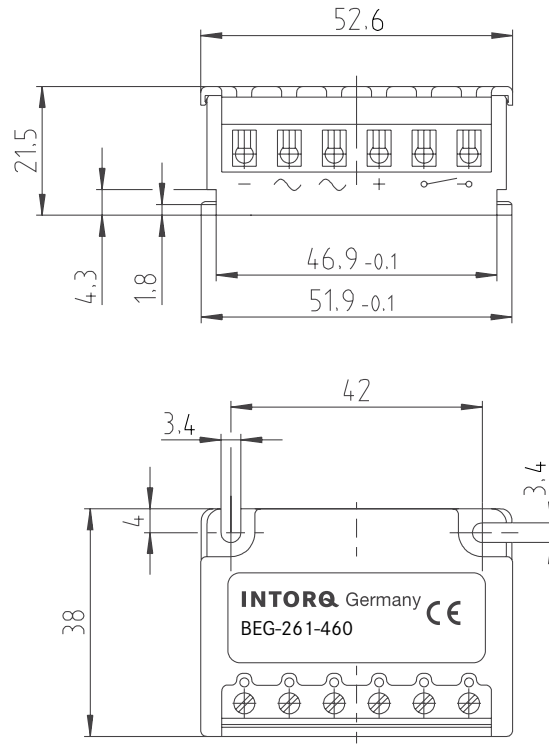

6-pole half-wave rectifier

BEG-262-460
BEG-261-460
BEG-262-555
BEG-261-555

Application area

Current supply for spring-applied brakes from AC mains (normal excitation)
Example: 180 V coil on 400 V mains

Technical data

Max. supply voltage	460 V~ / 555 V~
Max. DC current at 60°C	0.75 A
Max. ambient temperature	80°C

The rectifiers are protected against overvoltage by input and output varistors. BEG-162-270/161-270/262-460/261-460 rectifiers also contain the spark suppressor required by VDE 0580 Section 26.

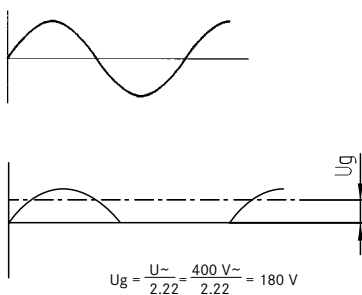

Accessories

Bridge/half-wave rectifiers

Once a set overexcitation time has elapsed, the bridge/half-wave rectifiers switch from bridge rectification to half-wave rectification. This makes it possible to improve

switching performance or reduce power in accordance with load dimensioning.

Rectifier type	Supply voltage [V AC]	Overexcitation		Holding current derating	
		Coil voltage [V DC]	Size	Coil voltage [V DC]	Size
BEG-56 1-255-030	230	103	06 ... 25	205	06 ... 14
BEG-56 1-255-130			-		16 ... 25
BEG-56 1-440-030-1	400	180	06 ... 25		-

The information in this table is valid for the BFK458 with standard spring configuration and for designs without pole shim (assignment for other brakes on request).

Dimensions

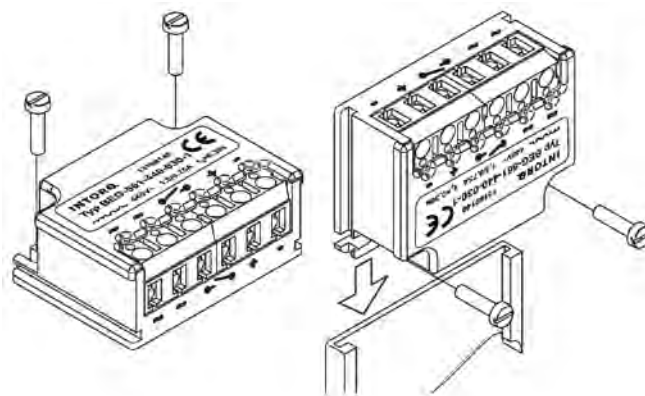
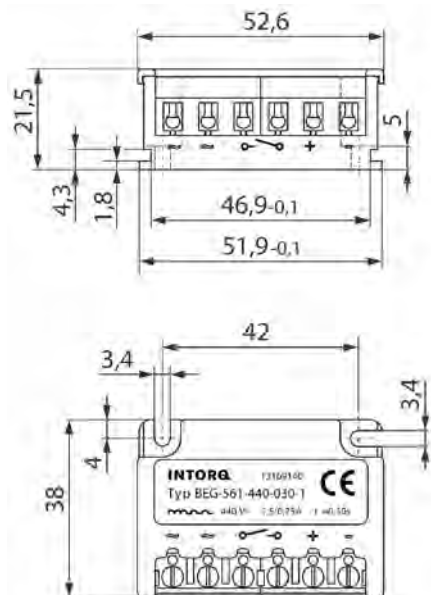

Connection diagrams

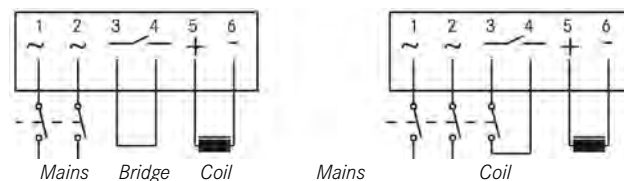

Technical data

Rectifier type	
Output voltage with bridge rectification	0.9xU1
Output voltage with half-wave rectification	0.45xU1
Ambient temperature (storage/operation) [°C]	-25...+70

In the case of switching on the DC side (fast engagement) switching must also occur on the AC side! Otherwise, overexcitation will not occur on restarting.

Type	Input voltage U1 (40 Hz ... 60 Hz)			Max. current I _{max}		Overexcitation time t _o (± 20%)		
	min [V~]	Rated [V~]	max [V~]	Bridge [A]	Half-wave [A]	at U 1 [s]	at U 1 r [s]	at U 1 max [s]
BEG-56 1-255-030 BEG-56 1-255-130	160	230	255	3.0	1.5	0.430	0.300	0.270
						1.870	1.300	1.170
BEG-56 1-440-030-1	230	400	440	1.5	0.75	0.500	0.300	0.270

Accessories

Fastening options

4-pole rectifier

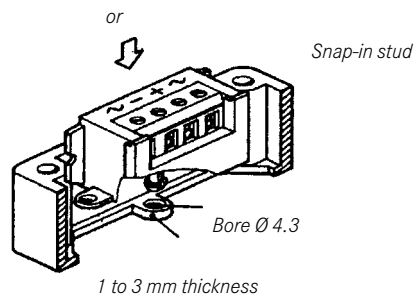
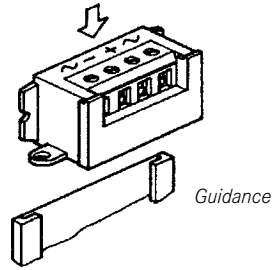
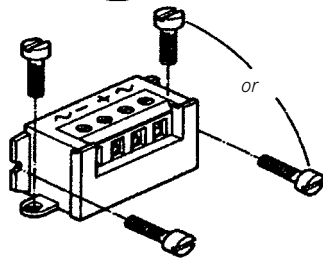
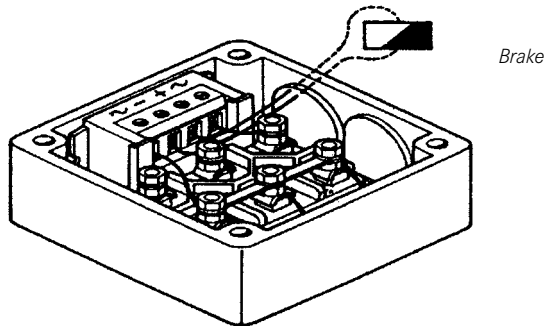

Fastening options

6-pole rectifier

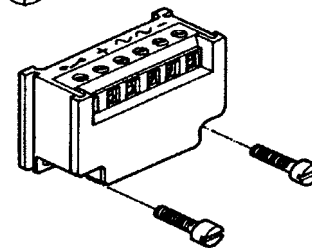
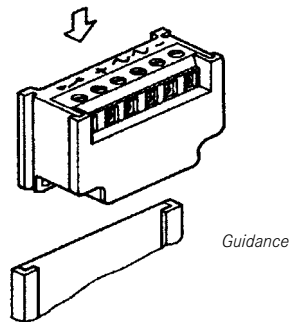
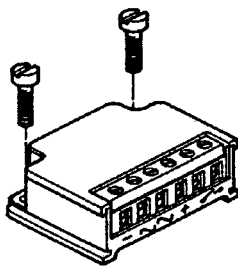
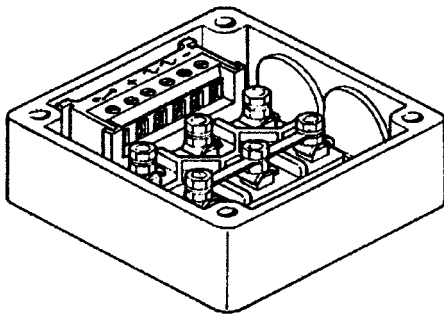

Accessories

Connection diagrams

DC switching

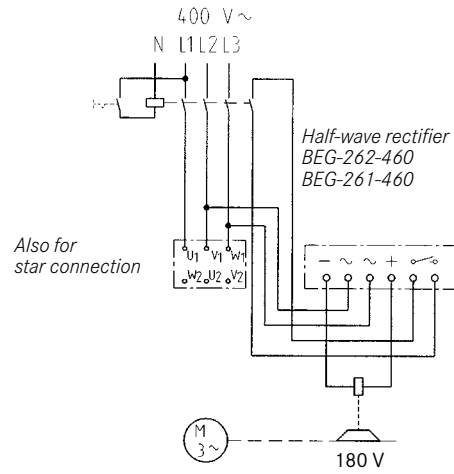
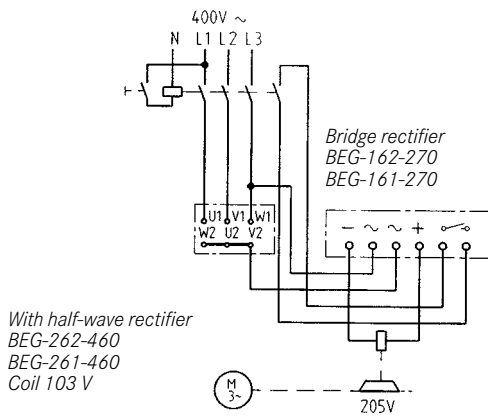

AC switching

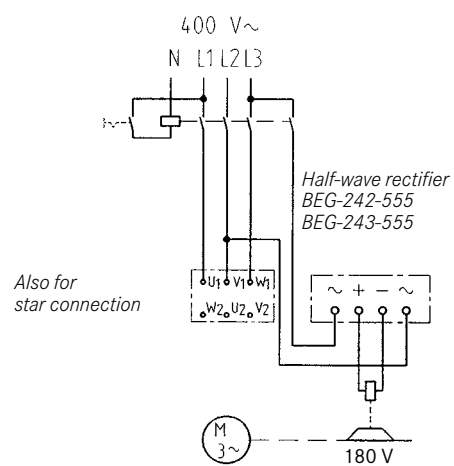
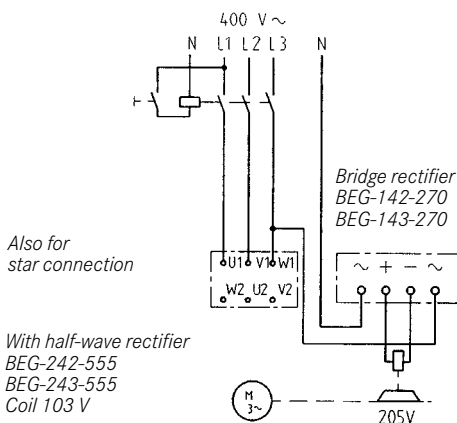

AC switching parallel to the motor

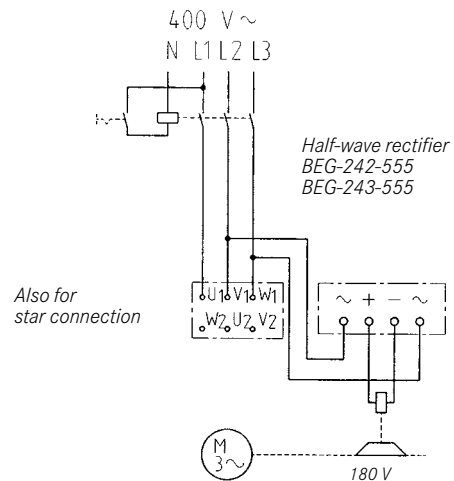
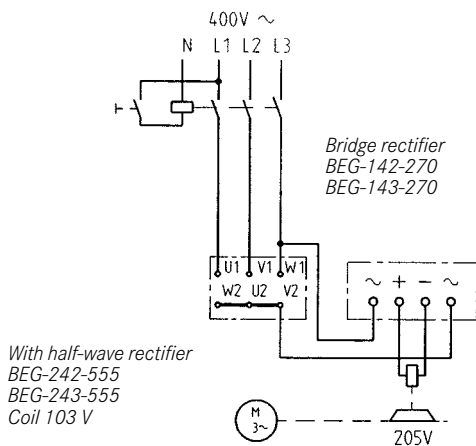

Accessories

Supply voltage selection table

Rectifier type and rated coil voltage for mains voltage

Alternating voltage [V]	Rectifier	Rectifier type 4-pole	Spark suppressor	Rectifier type 6-pole	Coil rated voltage [V]
		1 A at 60°C	INTORQ	0.75 A at 60°C	
42 V	Half-wave	BEG-243/242-555	14.198.00.01	BEG-262/261-460	20 V
48 V	Bridge	BEG-142/143-270	14.198.00.01	BEG-162/161-270	42 V
	Half-wave	BEG-243/242-555	14.198.00.01	BEG-262/261-460	20 V
110 V	Bridge	BEG-142/143-270	14.198.00.02	BEG-162/161-270	103 V
220 V	Bridge	BEG-142/143-270	14.198.00.04	BEG-162/161-270	205 V
	Half-wave	BEG-243/242-555	14.198.00.02	BEG-262/261-460	103 V
230 V	Bridge	BEG-142/143-270	14.198.00.04	BEG-162/161-270	205 V
	Half-wave	BEG-243/242-555	14.198.00.02	BEG-262/261-460	103 V
240 V	Bridge	BEG-142/143-270	14.198.00.04	BEG-162/161-270	215 V
	Half-wave	BEG-243/242-555	14.198.00.02	BEG-262/261-460	103 V
255 V	Bridge	BEG-142/143-270	14.198.00.04	BEG-162/161-270	225 V
277 V	Half-wave	BEG-243/242-555	14.198.00.03	BEG-262/261-460	127 V
290 V	Half-wave	BEG-243/242-555	14.198.00.03	BEG-262/261-460	127 V
380 V	Half-wave	BEG-243/242-555	14.198.00.03	BEG-262/261-460	180 V
400 V	Half-wave	BEG-243/242-555	14.198.00.03	BEG-262/261-460	180 V
415 V	Half-wave	BEG-243/242-555	14.198.00.03	BEG-262/261-460	180 V
420 V	Half-wave	BEG-243/242-555	14.198.00.03	BEG-262/261-460	180 V
440 V	Half-wave	BEG-243/242-555	14.198.00.04	BEG-262/261-460	205 V
460 V	Half-wave	BEG-243/242-555	14.198.00.04	BEG-262/261-460	205 V
480 V	Half-wave	BEG-243/242-555	14.198.00.04	BEG-262/261-555	215 V
500 V	Half-wave	BEG-243/242-555	14.198.00.04	BEG-262/261-555	225 V
555 V	Half-wave	BEG-243/242-555	14.198.00.04	BEG-262/261-555	250 V

* Spark suppressor without capacitor. For optimum spark suppression, we recommend the use of spark suppressor 14.198.00.04.

■ Max. rated coil voltage: 250 V
Standard rated voltages: 24, 96, 103, 170, 180, 190, 205 V

Selection

Basic information

The size of a brake is largely determined by the required braking torque M_{req} .

The inertias to be braked (moments of inertia), the relative speeds, the braking times and the operating frequencies also have to be considered in the calculations. Marginal conditions, such as ambient temperature, air humidity, dust and mounting position should be known. In the event of extreme/critical operating conditions, please consult the manufacturer. The brake is dimensioned in accordance with VDI guideline 2241.

Friction surfaces must always be kept free of oil and grease.

For explanations of the terms used in the calculation, please refer to the list of abbreviations on page 5.

Safety factor

To ensure the necessary transmission security even under extreme operating conditions, the calculated braking torque is multiplied by safety factor K , which depends on the operating conditions.

$$K \geq 2$$

Load types

In practice, the following load types mainly occur:

$$M_{req} = M_a \cdot K \leq M_K$$

$$M_a = \frac{J_{load} \cdot \Delta n_0}{9.55 \cdot \left(t_3 - \frac{t_{12}}{2} \right)}$$

$$M_{req} = \frac{J_{load} \cdot \Delta n_0}{9.55 \cdot \left(t_3 - \frac{t_{12}}{2} \right)} \cdot K$$

Dynamic plus static load

Most applications belong to this category, as in most cases there is not only a static torque but also a dynamic load.

$$M_{req} = (M_a \pm M_L) \cdot K \leq M_K$$

$$M_{req} = \left(\frac{J_L \cdot \Delta n_0}{9.55 \cdot \left(t_3 - \frac{t_{12}}{2} \right)} \pm M_L \right) \cdot K \leq M_K$$

+ M_{load} = to be used when lowering a load, for example

- M_{load} = for normal braking

Approximate determination of the required braking torque and the size

If only the drive power to be transmitted is known, the required torque or braking torque can be determined as follows:

$$M_{req} = 9550 \frac{P}{\Delta n_0} \cdot K \leq M_K$$

Thermal load

For high operating frequencies and friction energy/switching cycle, the brake should be subject to thermal checking. The friction energy per switching cycle is calculated as follows:

$$Q = \frac{J_L \cdot \Delta n_0^2}{182.5} \cdot \frac{M_K}{M_K \pm M_{load}}$$

- M_{load} = to be used when lowering a load, for example

+ M_{load} = for normal braking

The permissible friction energy per switching cycle at a given operating frequency can be taken from the diagrams on page 14. If the friction energy per switching cycle is known, the permissible operating frequency can be taken from the diagrams mentioned above.

Selection

Calculation example

The following technical data is known:

$$P = 3 \text{ kW}$$

$$\Delta n_0 = 1450 \text{ rpm}$$

$$J_{\text{load}} = 0.52 \text{ kgm}^2 \text{ total}$$

$$t_3 = 2 \text{ s}$$

$$M_{\text{load}} = 15 \text{ Nm}$$

$$S_h = 6 \text{ operations/h}$$

Approximate determination of the required braking torque and the size:

$$M_{\text{req}} = 9550 \frac{P}{\Delta n_0} \cdot K$$

$$M_{\text{req}} = 9550 \frac{3}{1450} \cdot 2 = 40 \text{ N}$$

Assume INTORQ BFK458-14

Calculating the required braking torque

$$M_{\text{req}} = \left(\frac{J_{\text{load}} \cdot \Delta n_0}{9.55 \cdot \left(t_3 - \frac{t_{12}}{2} \right)} - M_L \right) \cdot K$$

$t_{12} = 0.025 \text{ s}$ (see page 14)

$$M_{\text{req}} = \left(\frac{0.52 \cdot 1450}{9.55 \cdot \frac{2 - 0.025}{2}} - 15 \right) \cdot 2 = 50 \text{ Nm}$$

Therefore, INTORQ BFK458-14 is chosen.

$$M_K = 60 \text{ Nm} > M_{\text{req}} = 50 \text{ Nm}$$

Thermal checking

$$Q = \frac{J_L \cdot \Delta n_0^2}{182.5} \cdot \frac{M_K}{M_K \pm M_L}$$

$$Q = \frac{0.52 \cdot 1450^2}{182.5} \cdot \frac{60}{(60 + 15)} = 4792 \text{ J}$$

Calculated switching energy $Q = 4792 \text{ J}$ /switching cycle
The diagram on page 14 shows a permissible switching energy of 30,000 J for size 14 at $S_h = 6 \text{ h}^{-1}$.

$$Q = 4792 \text{ J} < Q_{\text{perm}} = 30,000 \text{ J}$$

Therefore, the brake has been selected correctly.

Ordering example

Brake type INTORQ BFK458-14E or design N (with or without torque adjustment ring) is required, with additional manual release and cover ring.

Supply voltage 205 V = shaft diameter 25 mm.

INTORQ BFK458-14E, 205 V =, d = 25 mm

Product overview

BFK458 spring-applied brake with accessories

INTORQ BFK458-□□□

Complete stator

Size	<ul style="list-style-type: none"> ■ 06 ■ 08 ■ 10 ■ 12 ■ 14 ■ 16 ■ 18 ■ 20 ■ 25
Type	<ul style="list-style-type: none"> ■ E (with torque adjustment ring) ■ N (without torque adjustment ring)
Voltage	<ul style="list-style-type: none"> ■ 24 V ■ 96 V ■ 103 V ■ 170 V ■ 180 V ■ 190 V ■ 205 V
Braking torque	1.5 – 600 Nm (see torque graduations)
Cable length	<ul style="list-style-type: none"> ■ Standard from 100 mm – 1000 mm in 100 mm steps, from 1000 mm – 2500 mm in 250 mm steps
Manual release	<ul style="list-style-type: none"> ■ Mounted
Armature plate	<ul style="list-style-type: none"> ■ Standard ■ Hard chrome-plated (size 06 and above) ■ Noise-reduced (O-ring design) ■ With pole shim/brass film
Microswitch	<ul style="list-style-type: none"> ■ Operation monitoring (size 12 and above) ■ Wear monitoring (size 12 and above) ■ Manual release monitoring, direction of release away from motor (sizes 06-25) ■ Manual release monitoring, direction of release towards motor (sizes 06-10)
Terminal box	<ul style="list-style-type: none"> ■ Mounted (size 12 and above)
Temperature resistance -40 °C	<ul style="list-style-type: none"> ■ With hard-chrome-plated friction surfaces (armature plate and flange are essential) ■ With temperature-resistant fixing screws

Accessories

Rotor	<ul style="list-style-type: none"> ■ Plastic (only for size 06/08) ■ Aluminium ■ Noise-reduced (rotor with sleeve)
Rotor with low rate of wear	<ul style="list-style-type: none"> ■ Aluminium ■ Noise-reduced (rotor with sleeve)
Hub	For bore diameter, see Dimensions
Fixing screw set	<ul style="list-style-type: none"> ■ For mounting on the flange ■ For mounting on the motor/friction plate ■ For flange with through hole (up to and including size 16) ■ For connection flange/double brake
Manual release	<ul style="list-style-type: none"> ■ As mounting kit
Terminal box	<ul style="list-style-type: none"> ■ As mounting kit
Flange	<ul style="list-style-type: none"> ■ Friction plate (up to and including size 16) ■ Flange ■ Tacho flange ■ Connection flange double brake
Seal	<ul style="list-style-type: none"> ■ Cover ring ■ Shaft sealing ring (shaft diameter on request) ■ Cap ■ Brake cover
Electrical accessories	
Bridge rectifier	<ul style="list-style-type: none"> ■ 4-pole without snap-in stud ■ 4-pole with snap-in stud ■ 6-pole vertical, integrated spark suppressor ■ 6-pole horizontal, integrated spark suppressor
Half-wave rectifier	<ul style="list-style-type: none"> ■ 4-pole without snap-in stud ■ 4-pole with snap-in stud ■ 6-pole vertical, integrated spark suppressor ■ 6-pole horizontal, integrated spark suppressor
Spark suppressor	<ul style="list-style-type: none"> ■ Yes