

CABINETS

VISIONCAB

NEW SIZES



ORDERING INFORMATION										
Catalog No.	External Dimensions H x W x D			Useable Dimensions H x D		Panel Space Height Inches U		Cabinet Wgt. (Lbs.)	Add'l Fixed Ventilated Shelf Catalog No.	Shelf Wgt. (Lbs.)
VC-9920	14.49"	23.62"	17.72"	11.38"	11.22"	10.50"	6	50		
VC-9921	19.72"	23.62"	17.72"	16.61"	11.22"	15.75"	9	57		
VC-9922	25.00"	23.62"	17.72"	21.89"	11.22"	21.00"	12	69	SH-12704	4
VC-9923	30.27"	23.62"	17.72"	27.16"	11.22"	26.25"	15	80		
VC-9924	35.40"	23.62"	17.72"	32.29"	11.22"	31.50"	18	89		
VC-9930	14.49"	23.62"	23.62"	11.38"	17.12"	10.50"	6	56		
VC-9931	19.72"	23.62"	23.62"	16.61"	17.12"	15.75"	9	66		
VC-9932	25.00"	23.62"	23.62"	21.89"	17.12"	21.00"	12	83	SH-12705	5
VC-9933	30.27"	23.62"	23.62"	27.16"	17.12"	26.25"	15	100		
VC-9934	35.40"	23.62"	23.62"	32.29"	17.12"	31.50"	18	117		

For full dimensional information, see our Web site at www.budind.com.

- ◆ Highly styled and versatile steel cabinet suitable for housing a variety of 19" panel width and EIA-310 compatible equipment
- ◆ Four adjustable mounting rails with square holes on EIA spacing; rails will accept either #12-24 (Bud #307) or M6 (#851-DLH) cage nuts
- ◆ Supplied with See-Thru removable front door with tempered glass window
- ◆ Solid steel removable rear and side panels
- ◆ Supplied with 110V AC, 65 CFM exhaust fan for cooling
- ◆ One fixed shelf included
- ◆ Four mar-resistant feet on bottom surface
- ◆ Finish: Fine textured black powder coating

Accessories

VisionCab will accept most of Bud's standard 19" panel space accessories. Call factory for details.

SMALL CABINETS

KEYBOARD ENCLOSURES

KB-13200

Base: .09", cover .05" aluminum, Two .50" knock-outs in rear, 7° 46' angle top. Weight 1 lb. 3 oz.

KB-13202

Base: .09", cover .05" aluminum, Two .87" knock-outs in rear, 7° 32' angle top. Weight 4 lbs. 2 oz.

KB-13201

Base: .09", cover .05" aluminum, Two .87" knock-outs in rear, 7° 40' angle top. Weight 2 lbs. 9 oz.

We can punch these enclosures to conform with your keyboard arrangements prior to forming. Prints available for your layouts.

Catalog No.	A	B	C	D	E	F	G	H	I	J	Wgt. (Lbs.)
KB-13200	7.21"	5.75"	1.71"	2.46"	7.00"	5.50"	5.54"	1.50"	2.25"	4.62"	1.2
KB-13201	12.84"	7.00"	1.84"	2.75"	12.62"	6.50"	6.56"	1.50"	2.37"	4.75"	2.4
KB-13202	17.46"	9.00"	1.84"	3.00"	17.25"	8.50"	8.57"	1.50"	2.62"	6.75"	3.4

General Features: Finish: Base: Gray Texture (GT). Cover: Prepainted smooth white. Self-adhesive black rubber feet. Keyboards are shipped completely assembled.

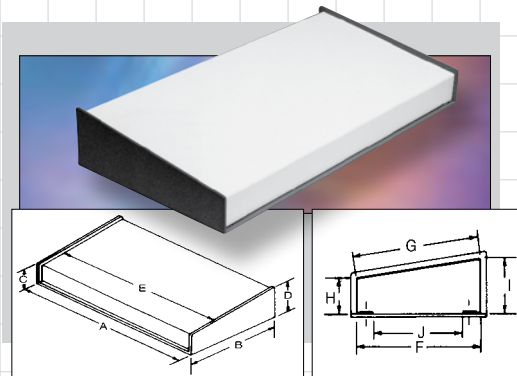

SMALL CABINETS

SLIMCAB™ DESKTOP CABINETS

Design Features: Cover .05" aluminum, panels .12" "Surface Shield" Aluminum. Sides vented for cooling. Three sizes available, all 1-U (1.75") High. Bonus Features: Suitable for desktop or 19" rack mount use with optional brackets. Finishes: Available in Sand Texture or Smooth Black (EBL).

Catalog No.	Description	Size	Wgt. Lbs.
CS-11221	Cabinet	8.50" x 8.00"	1.50
CS-11225	Cabinet	17.00" x 8.00"	2.75
CS-11227	Cabinet	17.00" x 16.00"	4.50
CS-11230	Bracket		0.50

