

# VALULINE SERIES

This Bud series has, for years, been one of the most requested by industry. The reasons: it's well styled, it's quality constructed, it's economical, and it's versatile — can be used independently or in a standard E.I.A. 19" cabinet.

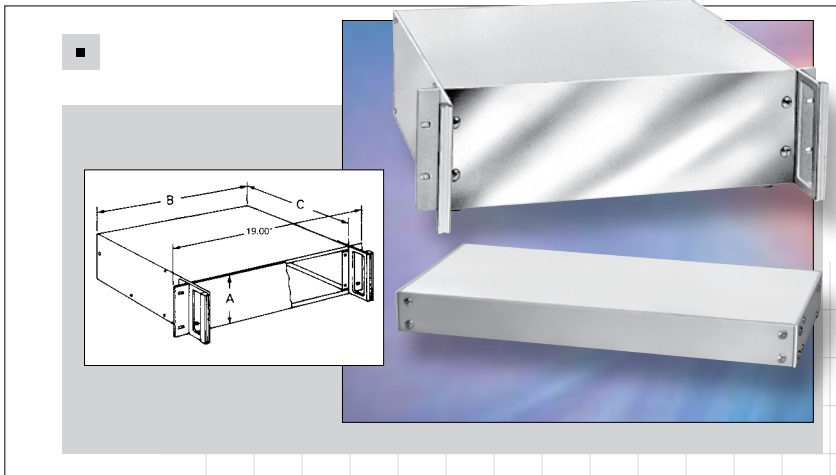

## Design Features

Front panel, 0.125" thick aluminum. Side panel, 0.09" thick aluminum; base, rear and top, 0.05" aluminum; handles, aluminum extrusions. Two detachable 11 gauge steel rack mounting brackets and rubber feet included. Accessory bails available. Shipped unassembled. Supports 25# equipment load.

## Bonus Features

Adhesive-backed paper protects front panel and provides surface for laying out position for drilling or punching. Some sizes available without handles.

## Finishes

Sides, White Texture (WH), rear and top, Smooth White.

## BAILS

### BAILS

Catalog No.	Width	Wgt. Oz.
BC-14210	10.00"	3.8
BC-14215	15.50"	4.2

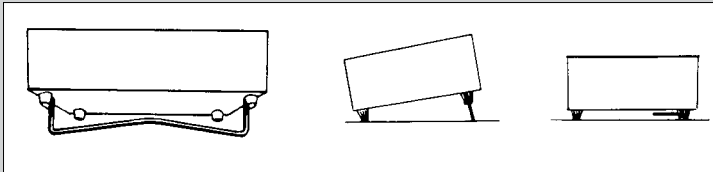

Bail is attached to specially designed front feet. Necessary hardware including two rear feet furnished with bail.

Bail in upright position tilts the cabinet.

Bail in retracted position fits into clearance provided by feet.

Catalog Number		Panel Height	Width	Depth	Est. Wgt.
Without Handles	With Handles	(A)	(B)	(C)	lbs.
NHC-14150	—	1.75"	8.50"	8.00"	1.7
NHC-14151	HC-14097	1.75"	17.00"	8.00"	3.0
NHC-14152	HC-14098	1.75"	17.00"	13.00"	4.8
NHC-14153	—	3.50"	8.50"	8.00"	2.3
NHC-14154	HC-14099	3.50"	17.00"	8.00"	4.3
—	HC-14100	3.50"	12.75"	13.00"	6.6
NHC-14155	HC-14101	3.50"	17.00"	13.00"	7.5
—	HC-14102	5.25"	12.75"	13.00"	8.5
NHC-14156	HC-14103	5.25"	17.00"	13.00"	9.3
NHC-14157	HC-14104	7.00"	17.00"	13.00"	10.8
—	HC-14105	8.75"	17.00"	13.00"	14.2
—	HC-14106	10.50"	17.00"	13.00"	14.4
—	HC-14107	10.50"	17.00"	15.00"	15.8
—	HC-14108	12.25"	17.00"	15.00"	16.9
—	HC-14109	14.00"	17.00"	15.00"	18.6

# RACK MOUNT BOX

Bud's Rack Mount Boxes were developed to house electronic components in a nonconductive 1-U, 2-U, and 3-U high plastic housing, which is 19" rack mountable to EIA standards. Unique construction allows for easy conversion into a desktop configuration.

## Design Features

- ◆ Durable ABS plastic with a UL94-HB flammability rating
- ◆ Usable in either a desktop or a rack mount configuration
- ◆ Available in three popular heights 1-U, 2-U, and 3-U
- ◆ Fully ventilated side panels provide maximum cooling of internal components
- ◆ Internal PCB mounting bosses
- ◆ 5 lb equipment load

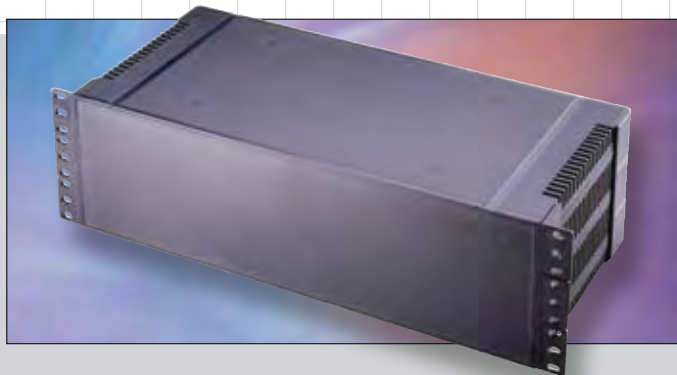

Catalog No.	Overall Dimensions H x W x D	Weight Oz.
PRM-14460	1.75" (1-U) x 19.00" x 8.00"	32.4
PRM-14462	3.50" (2-U) x 19.00" x 8.00"	40.5
PRM-14464	5.25" (3-U) x 19.00" x 8.00"	48.6