

RACK MOUNT CHASSIS

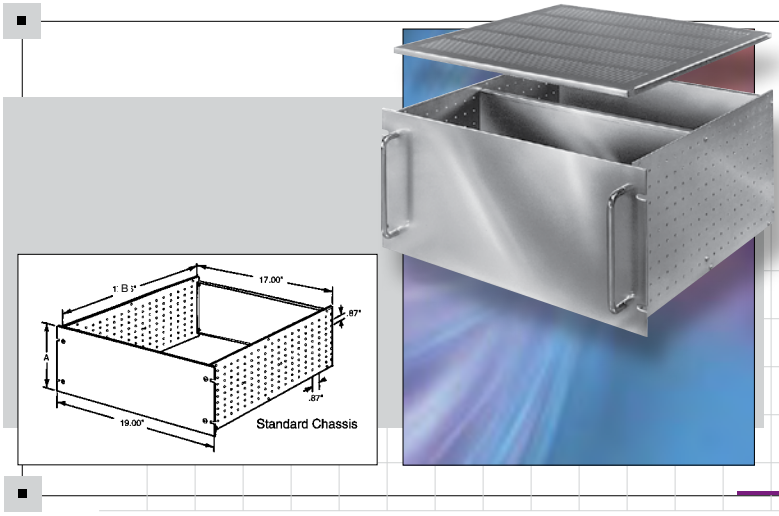

Side Panel mounting holes are punched on .87" grid to allow total flexibility in mounting of components. Rear Panel is fully adjustable from front to rear. Standard 19.00" Front Panels feature "Surface Shield" protection which provides surface for laying out drilling and punching positions.

Design Features

Included in standard chassis:

- ◆ Front Panel - .12" thick mill finish aluminum with "Surface Shield" protection.
- ◆ Side & Rear Panels - .09" aluminum.
- ◆ Finish - Natural. Other finishes available on request.
- ◆ Shipped unassembled with all necessary assembly hardware.
- ◆ 25 lb equipment load rating.
- ◆ 50 lb equipment load rating when using rear mounting bracket.

Optional Accessories

- ◆ Internal Chassis - .09" aluminum, natural finish. (see chart for Cat. Nos.) Can be mounted vertically or horizontally.
- ◆ Handles - Chrome plated steel (see chart for Cat. Nos.) 2 Required
- ◆ Solid Top or Bottom Cover - .05" aluminum, natural finish. Can also be used on bottom as full depth chassis for mounting components.
- ◆ Ventilated Top or Bottom Cover - .05" aluminum, natural finish, .12" x .75" slots for maximum ventilation.
- ◆ Slides - Two-piece slide, 20.00" long with 15.00" travel. Supplied in pairs. (Order mounting brackets BAS-5106 separately.) Requires two pairs of panel mounting rails.
- ◆ Rear Mounting Brackets - 16 GA. steel used to support rear of chassis. Requires two pairs of panel mounting rails.

Catalog Number	Height A	Depth B	Weight Lbs.	OPTIONAL ACCESSORIES							
				Internal Chassis	Weight (Lbs.)	Handles	Solid Top or Bottom Cover	Ventilated Top or Bottom Cover	Slides (Pair)	Rear Mounting Bracket	
RM-14212	5.25"	17.06"	4.25	C-14242	.75	H-9160-B					
RM-14213	7.00"	17.06"	5.25	C-14243	1.00	H-9111-B	TBC-14252 Wgt. 1.50 Lbs.	TBC-14262 Wgt. 1.25 Lbs.	AS-5002-A Wgt. 2.30 Lbs.		
RM-14214	8.75"	17.06"	6.50	C-14244	1.50	H-9112-B					
RM-14215	10.50"	17.06"	7.75	C-14245	1.75	H-9113-B					
RM-14222	5.25"	22.00"	4.75	C-14242	.75	H-9160-B				MB-14273 Wgt. 2.00 Lbs.	
RM-14223	7.00"	22.00"	5.90	C-14243	1.00	H-9111-B	TBC-14253 Wgt. 2.00 Lbs.	TBC-14263 Wgt. 2.305 Lbs.	AS-5002-A Wgt. 2.30 Lbs. or AS-5004 Wgt. 2.9 Lbs.		
RM-14224	8.75"	22.00"	7.75	C-14244	1.50	H-9112-B					
RM-14225	10.50"	22.00"	8.75	C-14245	1.75	H-9113-B					

Small Rack Mount Chassis

Five sizes of aluminum rack mount chassis. 1U and 2U versions, in three different depths. Adaptable for slide mounting. Requires two pairs of panel mounting rails when used with slides. Panels are .10" thick aluminum. Chassis are .05" thick aluminum.

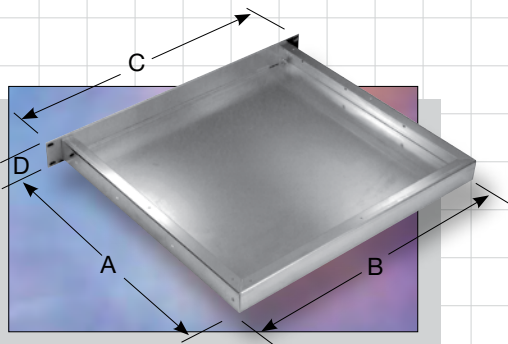

Catalog No.	Weight Lbs. (Approx.)	A	B	C	D
CH-14400	1.00	4.00"	17.00"	19.00"	1.75"
CH-14401	1.50	8.00"	17.00"	19.00"	1.75"
CH-14402	2.50	16.00"	17.00"	19.00"	1.75"
CH-14403	2.00	8.00"	17.00"	19.00"	3.50"
CH-14404	3.00	16.00"	17.00"	19.00"	3.50"

Small Rack Mount Chassis Cover

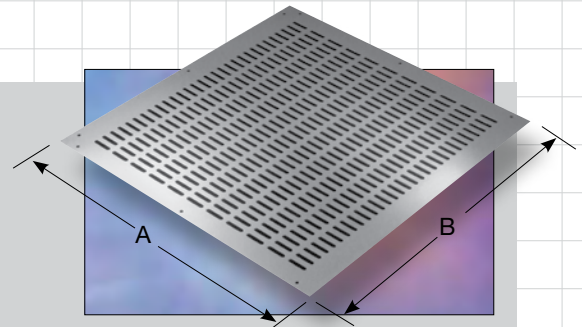

Ventilated chassis covers in .05" thick aluminum.

Catalog Number		Weight Oz. (Approx.)	A	B
Ventilated Cover	Solid Cover			
C-14430	C-14440	5.0	4.00"	17.00"
C-14431	C-14441	8.5	8.00"	17.00"
C-14432	C-14442	17.0	16.00"	17.00"