

MINIBOXES

Design Features

.04" aluminum alloy. Two sections slip together and may be joined by either built-in snap lock or sheet metal screws (included).

Bonus Features

Flanged sections assure proper shielding. Units can be used as separate housings or as part of larger assemblies.

Finishes

Natural (A) or Smooth Gray (B).

(Smooth Gray) Cat. No.	(Natural) Cat. No.	L	W	H	Wgt L-Bs.
CU-2100-B	CU-3000-A	2.75"	2.12"	1.62"	.25
CU-2101-B	CU-3001-A	3.25"	2.12"	1.62"	.25
CU-2102-B	CU-3002-A	4.00"	2.12"	1.62"	.25
CU-2103-B	CU-3003-A	4.00"	2.25"	2.25"	.25
CU-2104-B	CU-3004-A	5.00"	2.25"	2.25"	.25
CU-2105-B	CU-3005-A	5.00"	4.00"	3.00"	.50
CU-2106-B	CU-3006-A	5.25"	3.00"	2.12"	.25
CU-2107-B	CU-3007-A	6.00"	5.00"	4.00"	.75
CU-2108-B	CU-3008-A	7.00"	5.00"	3.00"	.75
CU-2109-B	CU-3009-A	8.00"	6.00"	3.50"	1.00
CU-2110-B	CU-3010-A	10.00"	6.00"	3.50"	1.25
CU-2111-B	CU-3011-A	12.00"	7.00"	4.00"	1.75

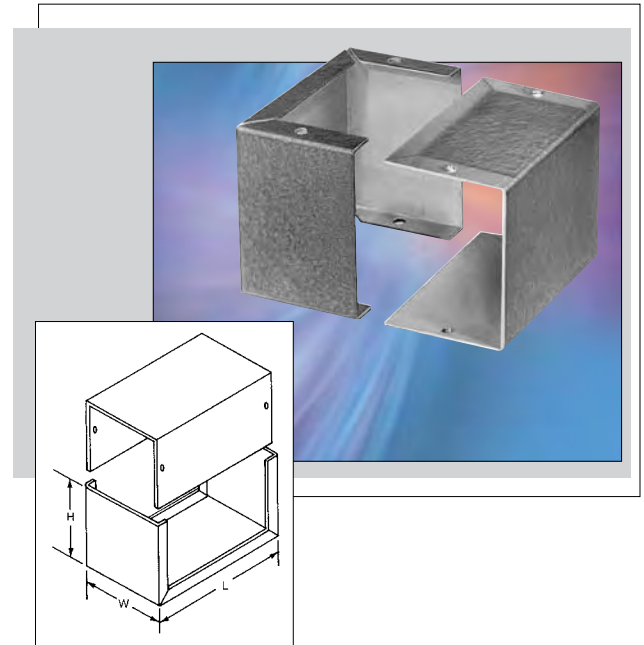

COMPUCAB SERIES

Another best-seller from Bud for good reason: These standard dual-slope enclosures have that custom-designed keyboard styling and, equally important, they can be used for a variety of instruments.

Design Features

Base and side, .09" aluminum; back panel and cover, .05" aluminum. Rubber feet furnished. Two configurations.

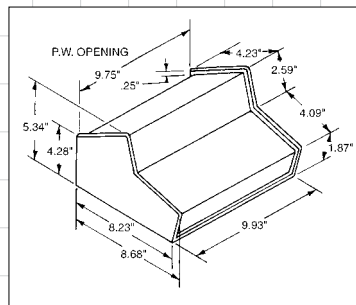
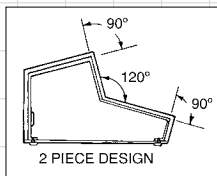

Catalog No.	Shipping Weight Lbs.
SC-13100	3.25
SC-13101	7.0

Bonus Features

Maximum visibility, no exposed screws on front panel area. Knockouts in louvered rear panel.

Finishes

Base, Black Texture (BT). Cover, Smooth White.

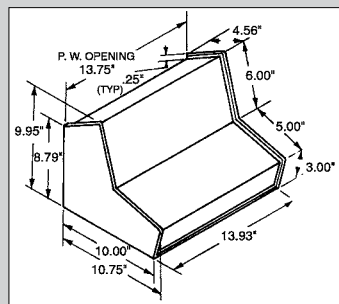
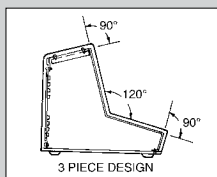

SC-13100

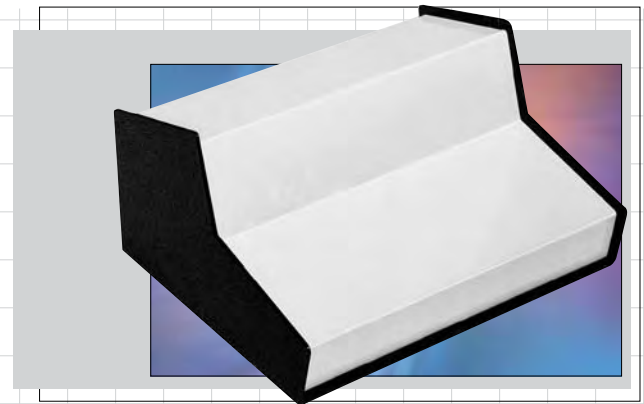

SC-13101

