

# CHAMPION SERIES

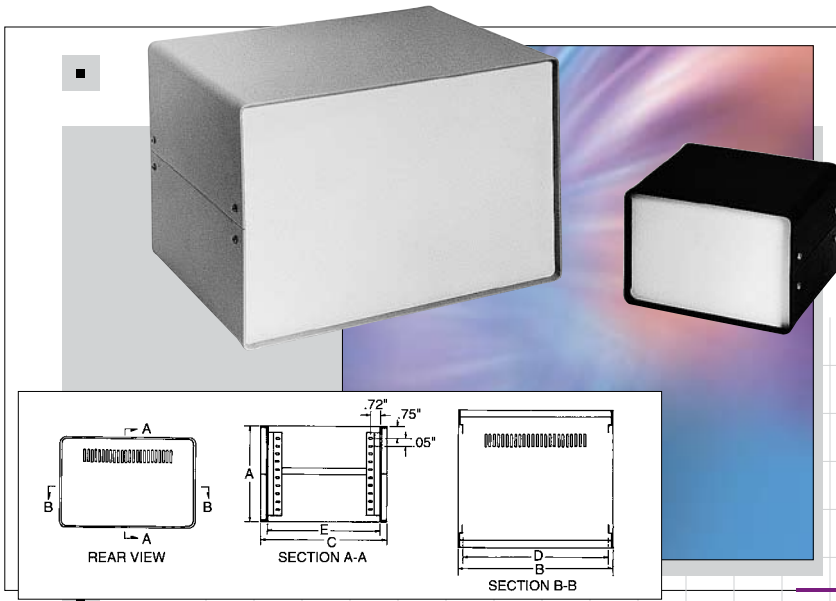

## Design Features

- ◆ Top, bottom, front and rear panels, .05" aluminum
- ◆ Ventilation slots in bottom and rear panel
- ◆ Easily assembled with eight self-threading screws
- ◆ No screws on front or rear panels
- ◆ Designed to allow for maximum interior space
- ◆ Removable top and bottom provide easy access to components
- ◆ Four self-adhesive rubber feet provided

## Finishes

Black Texture (BT) top and bottom, with smooth White front & rear panels.

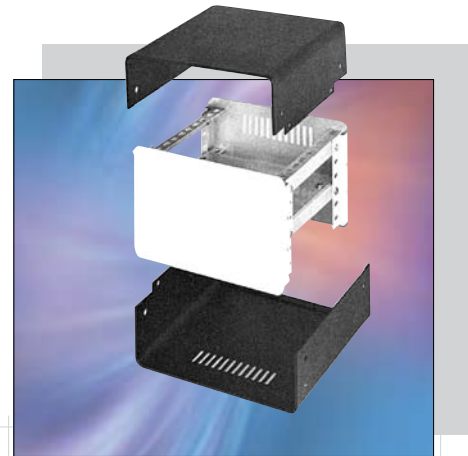

### CHAMPION SERIES

Catalog No.	Height A	Width B	Depth C	Clear Inside Width D	Clear Inside Depth E	Wgt. Lbs.
CS-11202	4.00"	6.00"	6.00"	5.37"	5.12"	1.5
CS-11204	4.00"	9.00"	8.00"	8.37"	8.12"	2.0
CS-11206	4.00"	12.00"	8.00"	11.37"	17.12"	2.5
CS-11208	6.00"	9.00"	8.00"	8.37"	7.12"	2.5
CS-11210	6.00"	12.00"	8.00"	11.37"	7.12"	3.0
CS-11212	6.00"	12.00"	10.00"	11.37"	9.12"	3.5
CS-11214	8.00"	9.00"	8.00"	8.37"	7.12"	3.0
CS-11216	8.00"	12.00"	10.00"	11.37"	9.12"	4.0

## OPTIONAL ACCESSORIES

### SUPPORT ANGLE KIT

Kit includes 2 support angles, 4 screws and 4 clip nuts.  
Material: .05" aluminum, natural finish.

### DESIGN FEATURES

- ◆ Support angles attach with only two screws per angle
- ◆ Component mounting holes punched on .50" centers
- ◆ Angles may be adjusted up and down at .50" increments
- ◆ Support angles, attached to front and rear panels, allow easy assembly of interior components before attaching top and bottom

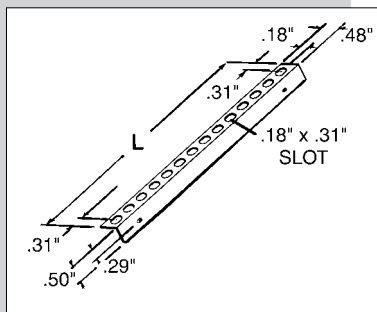

### CHASSIS KIT

Kit includes 1 chassis, 2 support angles, 8 screws and 8 clip nuts.  
Material: .05" aluminum, natural finish.

### DESIGN FEATURES

- ◆ .53" clearance between chassis and front and rear panels
- ◆ Chassis may be moved to front or back by .50" allowing maximum clearance for components and wire routing
- ◆ .50" flange on front and rear of chassis provides increased stiffness

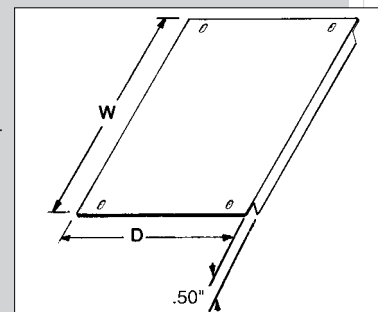

Catalog No.	Fits	Length	Wgt. Oz.
CSA-11262	CS-11202	5.12"	1.2
CSA-11264	CS-11204, 06, 08, 10, 14	7.12"	1.5
CSA-11266	CS-11212, 16	9.12"	1.8

CSH-11280 HARDWARE KIT: Additional hardware for component mounting consists of (4) #6-32 x .31" screws and (4) #6-32 clip nuts.

Catalog No.	Fits	Length	Wgt. Oz.	
CSC-11242	CS-11202	5.25"	4.06"	3.5
CSC-11244	CS-11204, 08, 14	8.25"	6.06"	6.3
CSC-11246	CS-11206, 10	11.25"	6.06"	8.0
CSC-11248	CS-11212, 16	11.25"	8.06"	10.2