

Model TR1 - Tru-Trac™

Encoder And Spring Loaded Measuring Wheel



Features

- Encoder And Measuring Wheel Solution Integrated Into One Compact Unit
- Spring Loaded Torsion Arm Makes Wheel Pressure Adjustments A Snap
- Easily Installed In A Vertical, Horizontal, or Upside-Down Orientation
- Operates Over A Variety Of Surfaces At Speeds Up To 3000 Feet Per Minute
- Integrated Module Simplifies Your System Design, Reducing Cost

FINALLY! An integrated encoder and spring loaded measuring wheel assembly available in one, easy-to-use, compact unit. The NEW Tru-Trac™ by Encoder Products Company is a versatile solution for tracking velocity, position, or distance over a wide variety of surfaces in almost any application. It's spring-loaded torsion arm provides a simple-to-adjust torsion load, allowing the Tru-Trac™ to be mounted in almost any orientation, even upside-down. The threaded shaft on the pivot axis is field reversible providing mounting access from either side. The Tru-Trac™ housing is a durable, conductive composite material that will eliminate static build up. With operating speeds up to 3000 feet per minute and a wide variety of configuration options, it's easy to see the Tru-Trac™ is the ideal solution for countless applications.

Common Applications

Web Tension Control, Paper Monitoring, Glue Dispensing, Linear Material Monitoring, Conveyor Systems, Printing, Labeling, Document Handling

Model TR1 - Tru-Trac™ Ordering Guide

Blue type indicates price adder options. Not all configuration combinations may be available. Contact Customer Service for details.

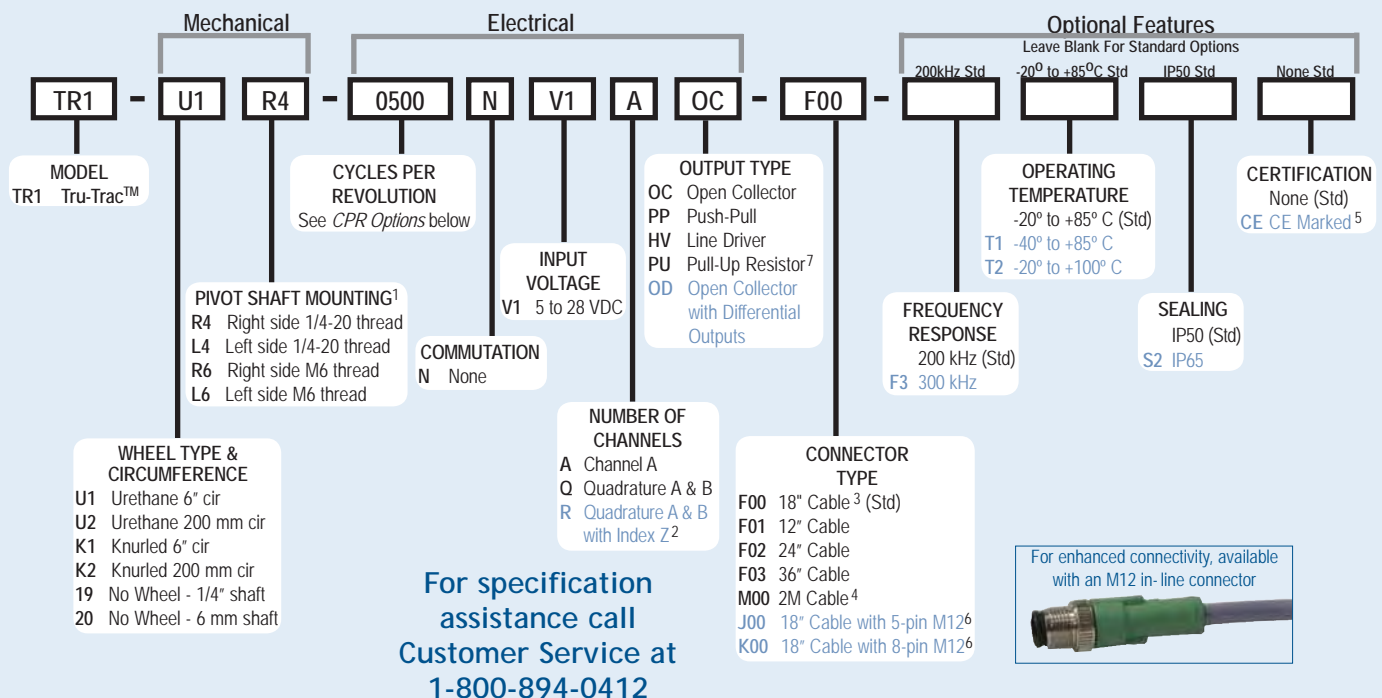

Model TR1 - Tru-Trac™ CPR Options

0001 thru 0189*	0200	0250	0256
0300	0315	0360	0400
0512	0580	0600	0800
1024	1200	1250	1800
2048	2500	2540	2000

*Contact Customer Service For Availability

New CPR values are periodically added to those listed. Contact Customer Service to determine all currently available values. Special disk resolutions are available upon request and may be subject to a one-time NRE fee.

NOTES:

- 1 See mechanical drawing. Shaft is reversible in the field.
- 2 Contact Customer Service for non-standard index gating or phase relationship options.
- 3 For non-standard English cable lengths enter 'F' plus cable length expressed in feet. Example: F06 = 6 feet of cable.
- 4 For non-standard metric cable lengths enter 'M' plus cable length expressed in meters. Example: M06 = 6 meters of cable.
- 5 Please refer to Technical Bulletin TB100: *When to Choose the CE Option* at www.encoder.com.
- 6 5-pin not available with Line Driver (HV) output. Additional cable lengths available. Please consult Customer Service.
- 7 With Input Voltage above 16 VDC, operating temperature is limited to 85° C.

Model TR1 - Tru-Trac™



Model TR1 - Tru-Trac™ Specifications

Electrical

- Input Voltage.....4.75 to 28 VDC max for temperatures up to 85° C
4.75 to 24 VDC for temperatures between 85° C to 100° C
- Input Current.....100 mA max (65 mA typical) with no output load
- Output Format.....Incremental- Two square waves in quadrature with channel A leading B for clockwise shaft rotation, as viewed from the wheel side. See *Waveform Diagrams* below.
- Output Types.....Open Collector- 20 mA max per channel
Push-Pull- 20 mA max per channel
Pull-Up- Open collector with 2.2K ohm Pull-Up
20mA max per channel
Line Driver- 20 mA max per channel (Meets RS 422 at 5 VDC supply)
- IndexOnce per revolution.
0190 to 2540 CPR: Gated to output A
0001 to 0189 CPR: Ungated
See *Waveform Diagrams* below.
- Freq. Response200 kHz standard, 300 kHz optional
- Noise ImmunityTested to BS EN61000-6-2; BS EN50081-2;
BS EN61000-4-2; BS EN61000-4-3;
BS EN61000-4-6, BS EN500811
- Symmetry.....180° (±18°) electrical
- Quad. Phasing90° (±22.5°) electrical
- Min. Edge Sep67.5° electrical
- AccuracyWithin 0.017° mechanical or 1 arc-minute from true position. (for CPR>189)

Mechanical

- Max Shaft Speed6000 RPM. Higher speeds may be achievable, contact Customer Service.
- Shaft MaterialStainless Steel
- Shaft Tolerance+0.0000/-0.0004" [+0.000/-0.010 mm]
- Radial Shaft Load ..5 lb max. Rated load of 2 to 3 lb for bearing life of 1.2 x 10¹⁰ revolutions
- Axial Shaft Load.....5 lb max. Rated load of 2 to 3 lb for bearing life of 1.2 x 10¹⁰ revolutions
- Starting Torque.....IP50 0.05 oz-in
IP65- 0.4 oz-in
- Electrical Conn.....18" cable (foil and braid shield, 24 AWG conductors), 5- or 8-pin M12 (12 mm) in-line connector with 18" cable (braid shield)
- MountingPivot shaft can be mounted from either side of the Tru-Trac™ housing, and is reversible in the field. Specify 1/4-20 or M6 threads
- Housing.....Stainless steel fibers in a high temperature nylon composite
- Wheel Width.....0.25"
- Weight.....5 oz typical

Environmental

- Operating Temp.....-20° to +85° C for standard models
-40° to +85° C for low temperature option
-20° to +100° C for high temperature option
- Storage Temp.....-25° to +85° C
- Humidity98% RH non-condensing
- Vibration10 g @ 58 to 500 Hz
- Shock80 g @ 11 ms duration
- SealingIP50 standard; IP65 available

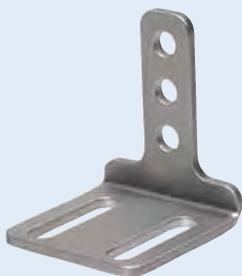

Accessory Angle Mounting Bracket for TR1 Tru-Trac™ can be ordered separately as part # 140104 Dimensional drawing available at www.encoder.com.

Model TR1 - Tru-Trac™

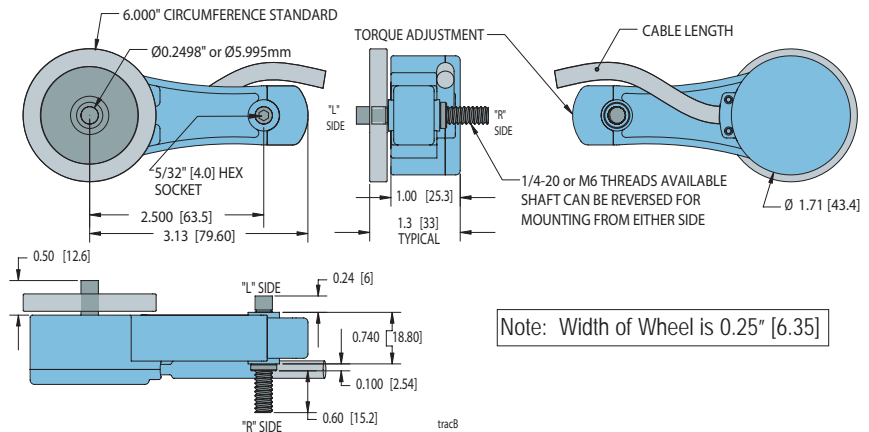

Note: Width of Wheel is 0.25" [6.35]

All dimensions are in inches with a tolerance of ±0.005" or ±0.01" unless otherwise specified
Metric dimensions are given in brackets [mm]

Model TR1 - Tru-Trac™ Applications



For Linear Applications the Tru-Trac™ can be mounted above or below the moving object, and the tension on the wheel adjusted for a wide range of applications such as packaging, conveyors, mail sorting, cut to length, labeling, gantries, etc.

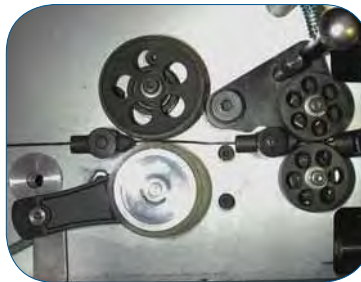

For Rotational Applications the Tru-Trac™ can be mounted in any orientation to monitor the position or velocity of many types of rotating equipment such as web tension control drums, rotary tables, printing, spooling, etc.



Waveform Diagram

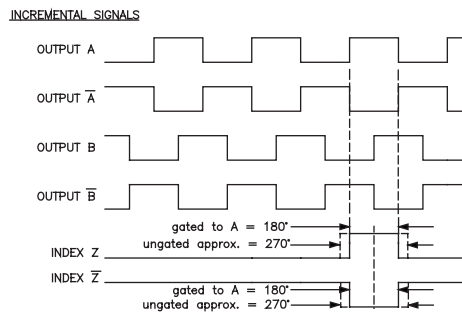

Waveform shown with optional complementary signals Ā, B̄, Z̄ for HV and OD outputs only.

Wiring Table

Function	Cable Wire Color	5-pin M12**	8-pin M12**
Com	Black	3	7
+VDC	White	1	2
A	Brown	4	1
A'	Yellow	--	3
B	Red	2	4
B'	Green	--	5
Z	Orange	5	6
Z'	Blue	--	8
Shield	Bare *	--	--

* CE Option: Cable shield (bare wire) is connected to internal case.
** Non-CE Option: Cable shield is connected to M12 connector body. CE Option: Cable shield is connected to M12 connector body, and internal case.

