

# DR738

## Direct Replacement For 444 Tach Style Encoder



### Features

- Standard REO 444 Style, 115 mm Diameter Flange
- Up to 30,000 PPR and Two Standard Shaft Sizes
- IP64 Sealing Available
- Extended Life Disk Technology

The DR738 is designed to provide a digital encoder signal format to replace traditional Tacho style feedback devices. The heavy duty bearings and mechanical assembly make the DR738 perfect for those applications requiring a rugged and dependable encoder. Typically replaces encoders from Hubner, Baumer, Tekel, etc. Domestic sourcing provides fast delivery, technical support, and repair services.

### Common Applications

Motion Control Feedback, Conveyers, Elevator Controls, Machine Control, Food Processing, Process Control, Robotics, Material Handling, Textile Machines

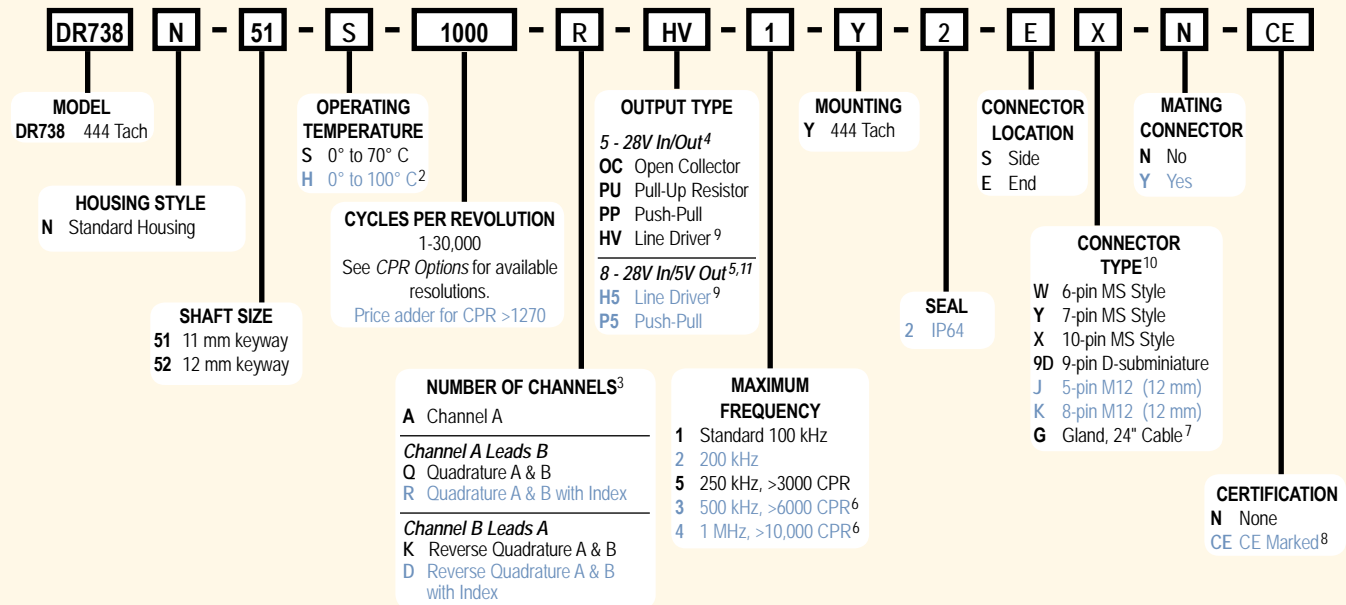

### Model DR738 CPR Options

0001*	0002*	0004*	0005*	0006*	0007*	0008*	0010*	0011*
0012*	0014*	0020	0021*	0024*	0025*	0028*	0030*	0032*
0033*	0034*	0035*	0038*	0040*	0042*	0045*	0050*	0060
0064*	0100	0120	0125	0128*	0144*	0150*	0160*	0200
0240*	0250	0254*	0256*	0300	0333*	0360	0400	0500
0512	0600	0625*	0635	0665*	0720	0768*	0800	0889
0900*	1000	1024	1200	1201 <sup>a</sup>	1203 <sup>a</sup>	1204 <sup>a</sup>	1250 <sup>a</sup>	1270 <sup>a</sup>
1440	1500	1800	2000	2048	2400 <sup>a</sup>	2500	2540 <sup>a</sup>	2880 <sup>a</sup>
3000 <sup>a</sup>	3600 <sup>a</sup>	4000 <sup>a</sup>	4096 <sup>a</sup>	5000 <sup>a</sup>	6000 <sup>a</sup>	7200 <sup>a</sup>	7500 <sup>a</sup>	9000 <sup>a</sup>
10,000 <sup>a</sup>	10,240 <sup>a</sup>	12,000 <sup>a</sup>	12,500 <sup>a</sup>	14,400 <sup>a</sup>	15,000 <sup>a</sup>	18,000 <sup>a</sup>	20,000 <sup>a</sup>	20,480 <sup>a</sup>
25,000 <sup>a</sup>	30,000 <sup>a</sup>							

\* Contact Customer Service for High Temperature Option.  
<sup>a</sup> High Temperature Option (H) limited to 85° C maximum for these CPR options.  
 New CPR values are periodically added to those listed. Contact Customer Service to determine all currently available CPR values. Special disk resolutions are available upon request.  
 A one-time NRE fee may apply.

### NOTES:

- 1 Available with I housing style only.
- 2 0° to 85° C for certain resolutions, see CPR Options.
- 3 Contact Customer Service for index gating options.
- 4 24 VDC max for high temperature option.
- 5 Standard temperature, 60 to 3000 CPR only.
- 6 Standard cable lengths only. For details, please refer to **Technical Bulletin TB116: Noise and Signal Distortion Considerations** at [www.encoder.com](http://www.encoder.com).
- 7 For Non-Standard Cable Lengths add a forward slash (/) plus cable length expressed in feet. Example: SG/6 = 6 feet of cable.
- 8 Please refer to **Technical Bulletin TB100: When to Choose the CE Option**.
- 9 Not available with 5-pin M12 or 6-pin MS connector. Available with 7-pin MS connector only without Index Z.
- 10 For Mating Connectors, Cables, and Cordsets see [www.encoder.com](http://www.encoder.com).
- 11 H5 and P5 outputs not available with CE option, or any End Mount MS Connector.

# DR738

## Direct Replacement For 444 Tach Style Encoder

### Model DR738 Specifications

#### Electrical

Input Voltage..... 4.75 to 28 VDC for temperatures up to 70° C  
 4.75 to 24 VDC for temperatures between 70° C to 100° C

Input Current..... 100 mA max with no output load

Input Ripple..... 100 mV peak-to-peak at 0 to 100 kHz

Output Format..... Incremental- Two square waves in quadrature with channel A leading B for clockwise shaft rotation, as viewed from the encoder mounting face. See *Waveform Diagrams* below.

Output Types..... Open Collector- 100 mA max per channel  
 Pull-Up- 100 mA max per channel  
 Push-Pull- 20 mA max per channel  
 Line Driver- 20 mA max per channel (Meets RS 422 at 5 VDC supply)

Index..... Occurs once per revolution. The index for units >3000 CPR is 90° gated to Outputs A and B. See *Waveform Diagrams* below.

Max Frequency..... Up to 1 MHz

Noise Immunity..... Tested to BS EN61000-4-2; IEC801-3; BS EN61000-4-4; DDENV 50141; DDENV 50204; BS EN55022 (with European compliance option); BS EN61000-6-2; BS EN50081-2

Symmetry..... 1 to 6000 CPR: 180° (±18°) electrical at 100 kHz output  
 6001 to 20,480 CPR: 180° (±36°) electrical

Quad Phasing..... 1 to 6000 CPR: 90° (±22.5°) electrical at 100 kHz output  
 6001 to 20,480 CPR: 90° (±36°) electrical

Min Edge Sep..... 1 to 6000 CPR: 67.5° electrical at 100 kHz output  
 6001 to 20,480 CPR: 54° electrical  
 >20,480 CPR: 50° electrical

Rise Time..... Less than 1 microsecond

Accuracy..... Instrument and Quadrature Error: For 200 to 1999 CPR, 0.017° mechanical (1.0 arc minutes) from one cycle to any other cycle. For 2000 to 3000 CPR, 0.01° mechanical (0.6 arc minutes) from one cycle to any other cycle. Interpolation error (units > 3000 CPR only) within 0.005° mechanical. (Total Optical Encoder Error = Instrument + Quadrature + Interpolation)

#### Mechanical

Max Shaft Speed..... 6000 RPM. Higher shaft speeds may be achievable, contact Customer Service.

Shaft Size..... 11 mm or 12mm (both have keyways)

Shaft Material..... 303 stainless steel

Shaft Rotation..... Bi-directional

Radial Shaft Load..... 27 lb max

Axial Shaft Load..... 27 lb max

Starting Torque..... 1.0 oz-in typical with IP64 seal

Moment of Inertia..... 5.2 x 10<sup>-4</sup> oz-in-sec<sup>2</sup>

Max Acceleration..... 1 x 10<sup>5</sup> rad/sec<sup>2</sup>

Electrical Conn..... 6-, 7-, or 10-pin MS Style, 5- or 8-pin M12 (12 mm), 9-pin D-subminiature, or gland with 24 inches of cable (foil and braid shield, 24 AWG conductors)

Housing..... Black non-corrosive finish

Bearings..... Precision ABEC ball bearings

Mounting..... 444 Tach Style Flange

Weight..... 22 oz typical

#### Environmental

Operating Temp..... 0° to 70° C for standard models  
 0° to 100° C for high temperature option (0° to 85° C for certain resolutions, see CPR Options.)

Storage Temp..... -25° to +85° C

Humidity..... 95% RH non-condensing

Vibration..... 10 g @ 58 to 500 Hz

Shock..... 50 g @ 11 p duration

Sealing..... IP64

### Model DR738 REO 444 Style 115 mm Diameter

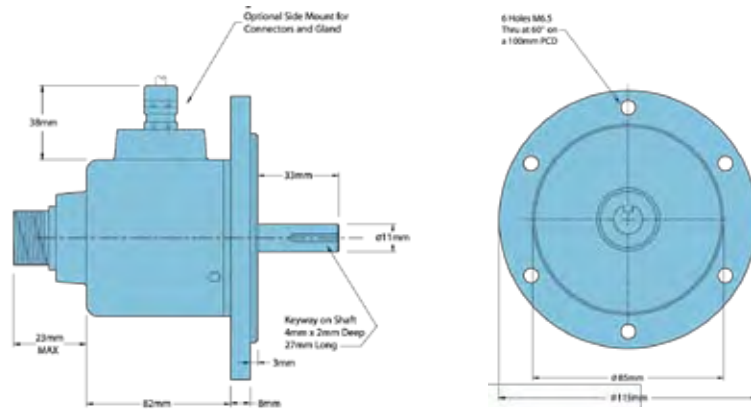

### Connector Pin-Outs

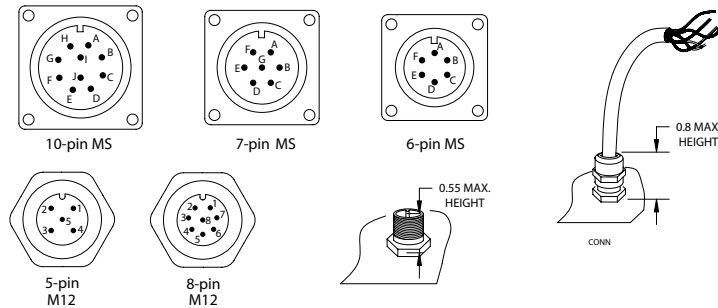

### Wiring Table

Function	Gland Cable Wire Color	5-pin M12 <sup>2</sup>	8-pin M12 <sup>2</sup>	10-pin MS	7-pin MS HV, HS	7-pin MS PU, PP, OC, PS	6-pin MS PU, PP, OC, PS	9-pin D-sub
Com	Black	3	7	F	F	F	A, F	9
+VDC	Red	1	2	D	D	D	B	1
A	White	4	1	A	A	A	D	2
A'	Brown	---	3	H	C	---	---	3
B	Blue	2	4	B	B	B	E	4
B'	Violet	---	5	I	E	---	---	5
Z	Orange	5	6	C	---	C	C	6
Z'	Yellow	---	8	J	---	---	---	7
Case	Green	---	---	G	G	G	---	8
Shield	Bare <sup>1</sup>	---	---	---	---	---	---	---

<sup>1</sup>CE Option: Cable shield (bare wire) is connected to internal case.  
<sup>2</sup>CE Option: Read Technical Bulletin TB111

### Output Waveform

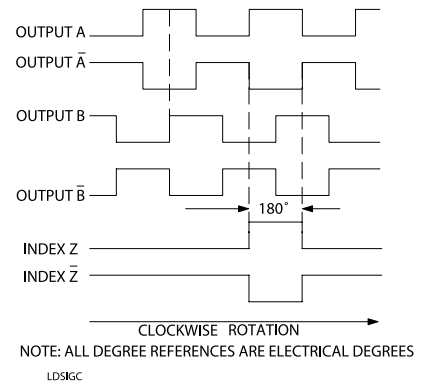

This Direct Replacement Encoder provided by:

