

DR686

Direct Replacement Encoder For Siemens 1XP8001



Designed as a drop in replacement for the Siemens 1XP8001 encoder, the DR686 is ready for delivery. The unique threaded shaft made this encoder hard to find, but now it is a standard order. Configurations can be ordered with either 1024 or 2048 CPR, with a 12 pin connector at the end of 18" of cable. Save time and money looking for a replacement encoder; The DR686 is the perfect solution!



Order Number	CPR
DR686-01	1024
DR686-02	2048

The Accu-Coder™ DR686 Features:

- Low profile (1.19") encoder body
- 2 piece construction; shaft screws into motor, then encoder attaches to shaft
- 1024 and 2048 CPR available
- Line Driver output
- Flex Arm mounting system makes installation easy and allows for insulation and isolation from vibration
- 12-pin connector at the end of 18" of cable
- Advanced Opto-ASIC technology for superior noise immunity
- Withstands temperatures up to 100° C

The Accu-Coder™ Advantage

- Get this encoder **FAST!**
- *Huge savings* in price comparison!
- The accuracy, reliability, and quality that only come from an Accu-Coder™
- Industry Best 3-year warranty!

DR686

Direct Replacement Encoder For Siemens 1XP8001



Model DR686 Specifications

Electrical

Input Voltage 4.75 to 28 VDC (16 VDC Max at 100° C)
 Input Current 100 mA max with no output load
 Output Format Incremental- Two square waves in quadrature with channel A leading B for clockwise shaft rotation, as viewed from the mounting face. See *Waveform Diagram* below.
 Output Types Line Driver- 20 mA max per channel (Meets RS 422 at 5 VDC supply)
 Freq. Response 200 kHz standard
 Noise Immunity Tested to BS EN61000-6-2; BS EN50081-2; BS EN61000-4-2; BS EN61000-4-3; BS EN61000-4-6, BS EN55011
 Symmetry 180° (±18°) electrical
 Quad. Phasing 90° (±22.5°) electrical
 Min. Edge Sep 67.5° electrical
 Accuracy Within 0.01° mechanical from one cycle to any other cycle, or 0.6 arc minutes

Mechanical

Max Shaft Speed 7500 RPM
 User Shaft Tolerances
 Radial Runout 0.007" max
 Axial Endplay ±0.030" max
 Starting Torque 0.50 oz-in
 Moment of Inertia 3.9 X 10⁻⁴ oz-in-sec²
 Max Acceleration 1 X 10⁵ rad/sec²
 Electrical Conn 18" cable (foil and braid shield, 24 AWG conductors) with 12-pin connector
 Housing Black non-corrosive finish
 Mounting Flex Arm Mount standard
 Weight 3.5 oz typical

Environmental

Operating Temp 0° to 100°C
 Storage Temp -40° to +100° C
 Humidity 98% RH non-condensing
 Vibration 10 g @ 58 to 500 Hz
 Shock 50 g @ 11 ms duration
 Sealing IP50

DR686 Dimensions

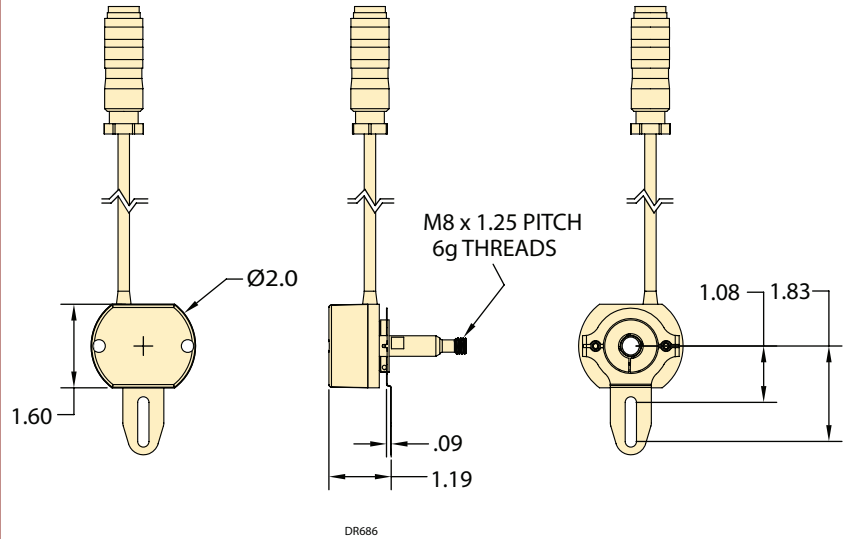

DR686 Wiring Table

DR686 WIRING	
PIN	FUNCTION
A	CHANNEL B'
B	+VDC
C	CHANNEL Z
D	CHANNEL Z'
E	CHANNEL A
F	CHANNEL A'
G	+VDC
H	CHANNEL B
J	N/C
K	COMMON
L	COMMON
M	+VDC

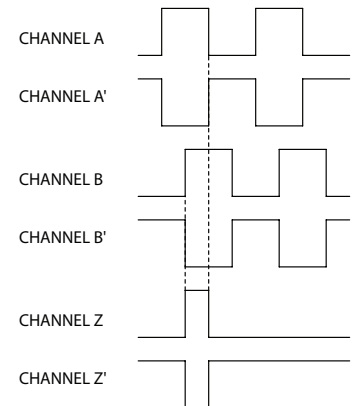

This Direct Replacement Encoder provided by;

