

# DR553

## Direct Replacement Encoder For Dynapar Rotopulser Model 60



The Accu-Coder™ DR553 is a direct replacement encoder for the Dynapar Rotopulser Model 60. These encoders are used on Ink Jet printers, cut to length applications, motor drive speed feedback, and a variety of other applications. If you have tried to order the Rotopulser 60 you may have encountered long lead times. The DR553 from Encoder Products Company is the perfect substitution for the Rotopulser 60.

Order The DR553 As A Direct Replacement Encoder For Videojet Triumph and Excel Printers!

Blue type indicates price adder options. Contact Customer Service for details.

<b>DR553</b>	<b>A</b>	<b>A</b>	<b>E</b>	<b>1000</b>	<b>A</b>	<b>B</b>
MODEL	HOUSING	SHAFT	OUTPUT TYPE	CYCLES PER REVOLUTION	CONNECTOR TYPE	SEAL
DR553 Size 20 (2.0") Encoder with 3.5" servo hub	A Standard Housing For Single Shaft	A 1/2" Diameter 1" Length with Flat	E 5-28V In/Out Push-Pull D Line Driver	Up to 2500 Call for resolution availability Add \$31 for CPR >1270	A MS Side Mount	B IP64

### Model DR553 CPR Options

0001	0002	0004	0005	0006	0010	0012	0020	0025
0040	0045	0050	0060	0064	0100	0120	0125	0128
0150	0180	0192	0200	0240	0250	0256	0300	0360
0400	0500	0512	0530	0600	0625	0720	0800	0900
1000	1024	1200	1270	1500	1800	2000	2400	2500

### The Accu-Coder™ DR553 Features:

- 3.5" servo hub on a rugged 2" encoder
- 1/2" stainless steel shaft
- Quadrature with index
- Resolutions up to 2500 CPR
- Line Driver and Push-Pull outputs
- 5 to 28 VDC
- 6-pin and 10-pin side mount MS connectors
- Sealing up to IP64

### The Accu-Coder™ Advantage

- Get this encoder FAST!
- *Huge savings* in price comparison!
- The accuracy, reliability, and quality that only come from an Accu-Coder™
- Industry Best 3-year warranty!



Direct Replacement Encoders

## Model DR553 Specifications

### Electrical

Input Voltage.....	4.75 to 28 VDC max for temperatures up to 70° C
Input Current.....	100 mA max with no output load
Input Ripple .....	100 mV peak-to-peak at 0 to 100 kHz
Output Format .....	Incremental- Two square waves in quadrature with channel A leading B for clockwise shaft rotation, as viewed from the encoder mounting face. See <i>Waveform Diagrams</i> below.
Output Type .....	Push-Pull- 20 mA max per channel Line Driver- 20 mA max per channel (Meets RS 422 at 5 VDC supply)
Index .....	Occurs once per revolution. See <i>Waveform Diagrams</i> below.
Freq Response.....	Up to 100 kHz.
Noise Immunity.....	Tested to BS EN61000-4-2; IEC801-3; BS EN61000-4-4; DDENV 50141; DDENV 50204; BS EN55022 (with European compliance option); BS EN61000-6-2; BS EN50081-2
Symmetry .....	180° (±18°) electrical at 100 kHz output
Quad Phasing.....	90° (±22.5°) electrical at 100 kHz output
Min Edge Sep.....	67.5° electrical at 100 kHz output
Rise Time.....	Less than 1 microsecond
Accuracy .....	Instrument and Quadrature Error: For 200 to 1999 CPR, 0.017° mechanical (1.0 arc minutes) from one cycle to any other cycle. For 2000 to 2500 CPR, 0.01° mechanical (0.6 arc minutes) from one cycle to any other cycle.

### Mechanical

Max Shaft Speed.....	8000 RPM. Higher shaft speeds may be achievable, contact Customer Service.
Shaft Size .....	0.50"
Shaft Rotation.....	Bi-directional
Radial Shaft Load.....	80 lb max. Rated load of 20 to 40 lb for bearing life of 1.5 x 10 <sup>9</sup> revolutions
Axial Shaft Load .....	80 lb max. Rated load of 20 to 40 lb for bearing life of 1.5 x 10 <sup>9</sup> revolutions
Starting Torque .....	1.0 oz-in typical with IP64 seal or no seal
Moment of Inertia .....	5.2 x 10 <sup>-4</sup> oz-in-sec <sup>2</sup>
Max Acceleration.....	1 x 10 <sup>5</sup> rad/sec <sup>2</sup>
Connector Type.....	6-, and 10-pin side mount MS connector
Housing.....	All metal construction with black protective coating
Bearings.....	Precision ABEC ball bearings
Mounting.....	3.5" servo mount
Weight.....	11 oz typical

### Environmental

Operating Temp.....	0° to 70° C for standard models
Storage Temp.....	-25° to +85° C
Humidity.....	98% RH non-condensing
Vibration.....	20 g @ 58 to 500 Hz
Shock.....	75 g @ 11 ms duration
Sealing.....	standard, or IP64

## DR553 Dimensions

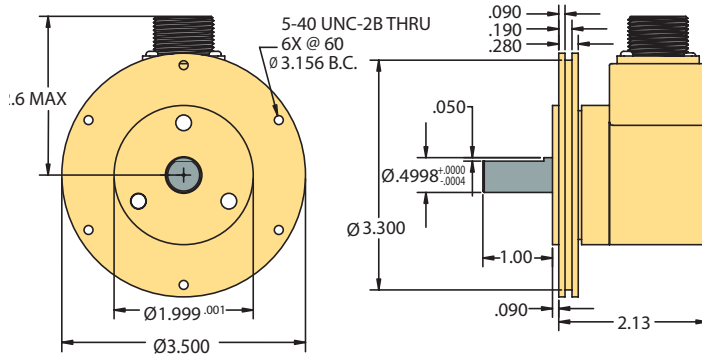

## DR553 Waveform Diagram

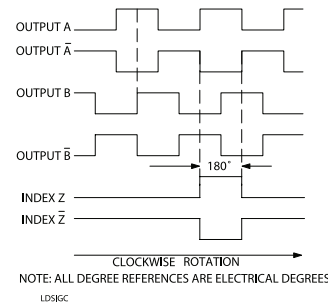

**Line Driver and Push Pull Waveform**  
The Line Driver output waveform is shown in the figure to the left. Output A leads Output B for clockwise rotation of the encoder shaft as viewed from the encoder mounting face. Push Pull outputs do not include complimentary channels.

## DR553 Wiring Table

Function	6-Pin MS (E)	10-Pin MS (D)
COM	C	C
+VDC	E	E
A	B	B
A'	----	G
B	D	D
B'	----	H
Z	A	A
Z'	----	I
Shield	F	F
Not Used	----	J

### Mating Connectors

To order a 6-pin MS mating connector order stock # 080014

To order a 10-pin MS mating connector order stock # 080113

This Direct Replacement Encoder provided by;

