

Model 858S



Features

- Industry Standard Size 58 (58 mm Diameter) Stainless Steel Package
- Up to 30,000 CPR
- 80 lb Maximum Axial and Radial Shaft Loading
- 100° C Operating Temperature Available
- IP66 Sealing Available

The Model 858S European Size 58 Accu-Coder™ is a heavy duty, extremely rugged, reliable encoder, in a 316 stainless steel package. Its compact design is well suited for harsh factory and plant floor environments, calling for a metric solution. The double-shielded ball bearings are rated at 80 pound maximum axial and radial shaft loading, to ensure a long operating life. Shock rating is 75 g for 11 milliseconds duration. With the optional heavy-duty shaft seal installed, the Model 858S is rated at IP66 (NEMA 4 & 13). Two European standard mounting options are available, the Clamping Flange (20 Type), or the Synchro Flange (26 Type).

Common Applications

Food Processing, Oil, Gas & Chemical Processing, Material Handling, Conveyors, Robotics, Elevator Controls, Textile Machines

Model 858S Ordering Guide

Blue type indicates price adder options. Not all configuration combinations may be available. Contact Customer Service for details.

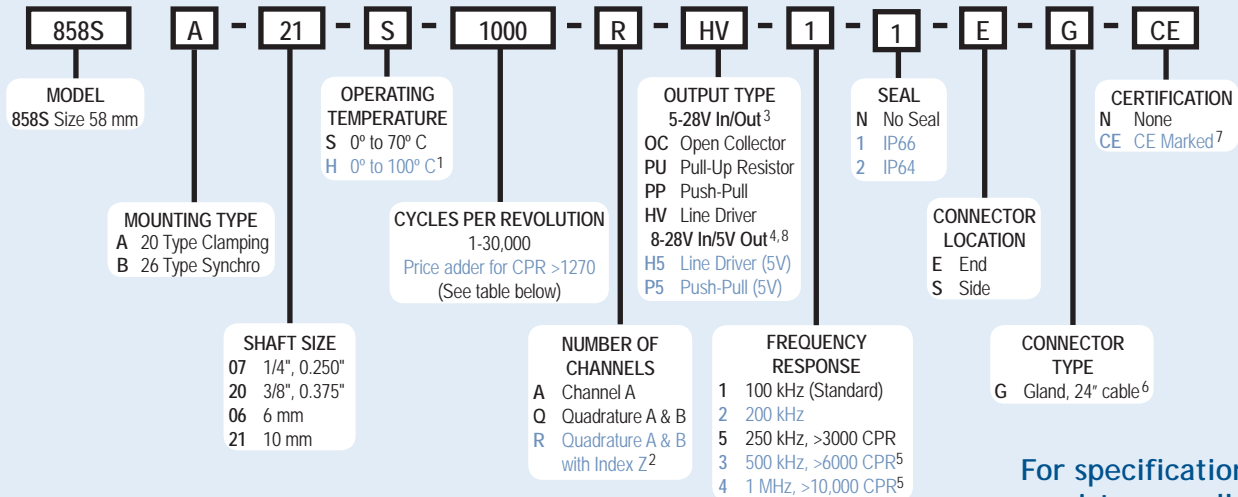

For specification assistance call Customer Service at 1-800-894-0412

Model 858S CPR Options

0001*	0002*	0004*	0005*	0006*	0007*	0008*	0010*	0011*
0012*	0014*	0020	0021*	0024*	0025*	0028*	0030*	0032*
0033*	0034*	0035*	0038*	0040*	0042*	0045*	0050*	0060
0064*	0100	0120	0125	0128*	0144*	0150*	0160*	0200
0240*	0250	0254*	0256*	0300	0333*	0360	0400	0500
0512	0600	0625*	0635	0665*	0720	0768*	0800	0889
0900*	1000	1024	1200	1201 ^a	1203 ^a	1204 ^a	1250 ^a	1270 ^a
1440	1500	1800	2000	2048	2400 ^a	2500	2540 ^a	2880 ^a
3000 ^a	3600 ^a	4000 ^a	4096 ^a	5000 ^a	6000 ^a	7200 ^a	7500 ^a	9000 ^a
10,000 ^a	10,240 ^a	12,000 ^a	12,500 ^a	14,400 ^a	15,000 ^a	18,000 ^a	20,000 ^a	20,480 ^a
25,000 ^a	30,000 ^a							

* Contact Customer Service for High Temperature Option.

^a High Temperature Option (H) limited to 85° C maximum for these CPR options.

New CPR values are periodically added to those listed. Contact Customer Service to determine all currently available CPR values. Special disk resolutions are available upon request.

A one-time NRE fee may apply.

NOTES:

- 1 0° to 85° C for certain resolutions, see CPR Options.
- 2 Contact Customer Service for non-standard [index gating options](#).
- 3 24 VDC max for high temperature option.
- 4 Standard temperature, 60 to 3000 CPR only.
- 5 Standard cable lengths only. For additional information please refer to Technical Bulletin TB116: [Noise and Signal Considerations](#) at [www.encoder.com](#).
- 6 For non-standard cable lengths, add a forward slash (/) plus cable length expressed in feet. Example: G/6 = 6 feet of cable.
- 7 For additional information please refer to Technical Bulletin TB100: [When to Choose the CE Option](#) at [www.encoder.com](#).
- 8 CE not available with H5/P5 output type options.

Model 858S

Model 858S Specifications

Electrical

Input Voltage.....4.75 to 28 VDC max for temperatures up to 70° C
 4.75 to 24 VDC for temperatures between 70° C to 100° C

Input Current 100 mA max with no output load

Input Ripple 100 mV peak-to-peak at 0 to 100 kHz

Output Format Incremental- Two square waves in quadrature with channel A leading B for clockwise shaft rotation, as viewed from the encoder mounting face. See *Waveform Diagrams* below.

Output Types Open Collector- 100 mA max per channel
 Pull-Up- 100 mA max per channel
 Push-Pull- 20 mA max per channel
 Line Driver- 20 mA max per channel (Meets RS 422 at 5 VDC supply)

Index Occurs once per revolution. The index for units >3000 CPR is 90° gated to Outputs A and B. See *Waveform Diagrams* below.

Freq Response..... Up to 1 MHz.

Noise Immunity..... Tested to BS EN61000-4-2; IEC801-3; BS EN61000-4-4; DENV 50141; DENV 50204; BS EN55022 (with European compliance option); BS EN61000-6-2; BS EN50081-2

Symmetry 1 to 6000 CPR: 180° (±18°) electrical at 100 kHz output
 6001 to 20,480 CPR: 180° (±36°) electrical

Quad Phasing..... 1 to 6000 CPR: 90° (±22.5°) electrical at 100 kHz output
 6001 to 20,480 CPR: 90° (±36°) electrical

Min Edge Sep..... 1 to 6000 CPR: 67.5° electrical at 100 kHz output
 6001 to 20,480 CPR: 54° electrical
 >20,480 CPR: 50° electrical

Rise Time..... Less than 1 microsecond

Accuracy..... Instrument and Quadrature Error : For 200 to 1999 CPR, 0.017° mechanical (1.0 arc minutes) from one cycle to any other cycle.
 For 2000 to 3000 CPR, 0.01° mechanical (0.6 arc minutes) from one cycle to any other cycle.
 Interpolation error (units > 3000 CPR only) within 0.005° mechanical. (Total Optical Encoder Error = Instrument + Quadrature + Interpolation)

Mechanical

Max Shaft Speed.....8000 RPM. Higher shaft speeds may be achievable, contact Customer Service.

Shaft Size 0.250", 0.375", 6 mm, 10 mm

Radial Shaft Load.....80 lb max. Rated load of 20 to 40 lb for bearing life of 1.5×10^9 revolutions

Axial Shaft Load 80 lb max. Rated load of 20 to 40 lb for bearing life 1.5×10^9 revolutions

Starting Torque 1.0 oz-in typical with IP64 seal or no seal
 3.0 oz-in typical with IP66 shaft seal

Moment of Inertia 5.2×10^{-4} oz-in-sec²

Max Acceleration 1×10^5 rad/sec²

Electrical Conn Gland with 24 inches of cable (foil and braid shield, 24 AWG conductors)

Housing..... Type 316 Stainless steel

Bearings..... Precision ABEC ball bearings

Mounting..... European Standard Clamping Flange (20 Type) and Synchro Flange (26 Type)

Weight..... 1.5 lb typical

Environmental

Operating Temp..... 0° to 70° C for standard models
 0° to 100° C for high temperature option (0° to 85° C for certain resolutions, see CPR Options.)

Storage Temp..... -25° to +85° C

Humidity..... 98% RH non-condensing

Vibration..... 20 g @ 58 to 500 Hz

Shock..... 75 g @ 11 ms duration

Sealing..... IP66 shaft seal (NEMA 13 and 4/4X); or IP64 bearing seal

Model 858 Clamping Flange 20 Type (A)

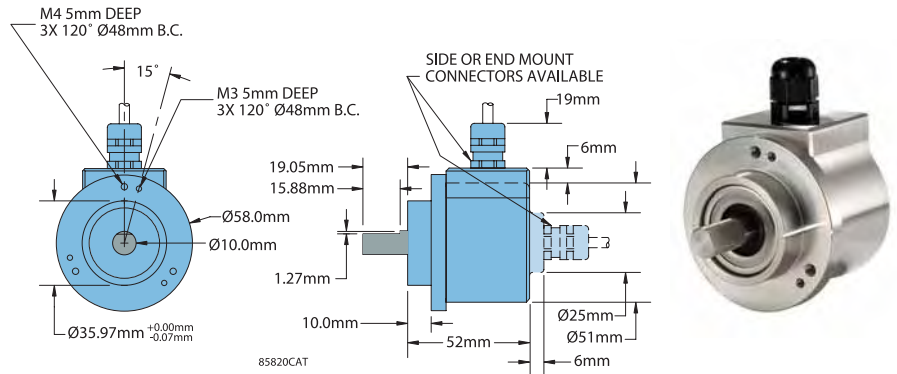

Model 858 Synchro Flange 26 Type (B)

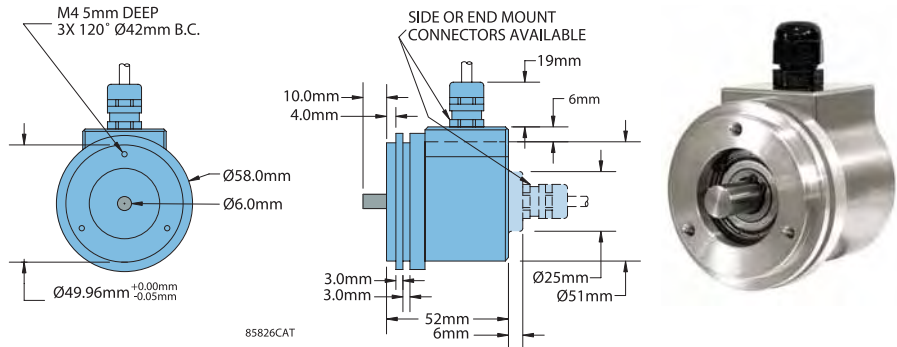

All dimensions are in millimeters with a tolerance of ±0.17 mm unless otherwise specified

Waveform Diagrams

Line Driver and Push-Pull

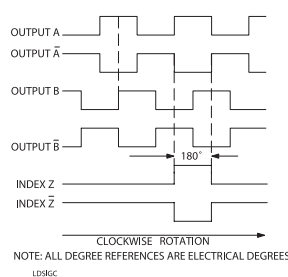

Open Collector and Pull-Up

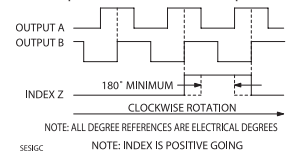

Wiring Table

Function	Gland Cable Wire Color
Com	Black
+VDC	Red
A	White
A'	Brown
B	Blue
B'	Violet
Z	Orange
Z'	Yellow
Shield	Bare*

* CE Option: Cable Shield (bare wire) is connected to internal case