

Model 775



Features

- Thru-Bore Design For Easy Mounting
- Bore Options to 1.375"
- Incorporates Opto-ASIC Technology
- Resolutions to 4096 CPR
- 100° C Operating Temperature Available
- CE Marking Available

The sleek design of the Model 775 Thru-Bore Series Accu-Coder™ makes form and function a successful reality. The slim profile and Thru-Bore design, makes installation easy by simply slipping the bore over motor shafts up to 1.375" in diameter. The advanced Opto-ASIC based electronics provide the superior noise immunity necessary in many industrial applications. With a variety of bore sizes, resolutions, and connector types, application possibilities are endless.

Common Applications

Motor Feedback, Velocity & Position Control, Food Processing, Robotics, Material Handling

Model 775 Ordering Guide

Blue type indicates price adder options. Not all configuration combinations may be available. Contact Customer Service for details.

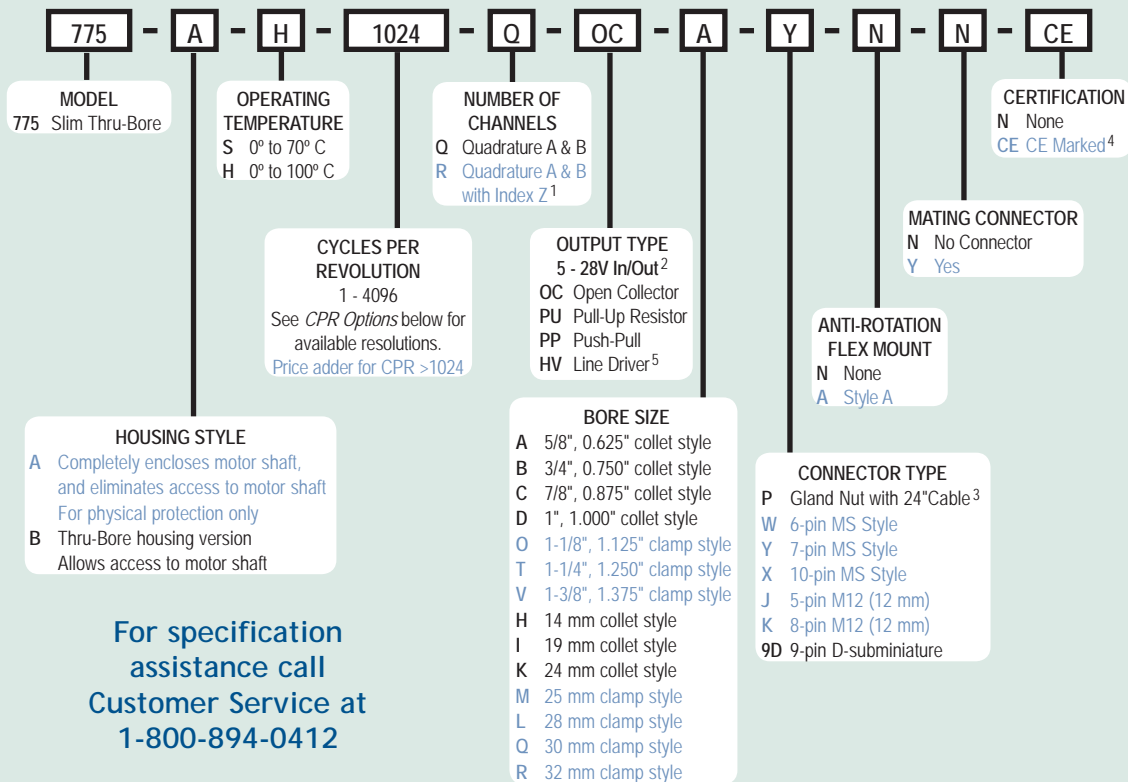

For specification assistance call Customer Service at 1-800-894-0412

Model 775 CPR Options

0060	0100	0120	0240	0250	0256
0500	0512	0600	1000	1024	2048
2500	4096				

Contact Customer Service for other disk resolutions; not all disk resolutions available with all output types

NOTES:

- 1 Contact Customer Service for [index gating options](#).
- 2 5 to 24 VDC max for high temperature option.
- 3 For non-standard cable lengths, add a forward slash (/) plus cable length expressed in feet. Example: P/6 = 6 feet of cable.
- 4 Please refer to [Technical Bulletin TB100: When to Choose The CE Option](#) at www.encoder.com.
- 5 Not available with 5-pin M12 or 6-pin MS connector. Available with 7-pin MS connector only without Index Z.

Model 775

Model 775 Specifications

Electrical

- Input Voltage.....4.75 to 28 VDC max for temperatures up to 70° C
4.75 to 24 VDC for temperatures between 70° C to 100° C
- Input Current.....100 mA max with no output load
- Input Ripple100 mV peak-to-peak at 0 to 100 kHz
- Output FormatIncremental- Two square waves in quadrature with channel A leading B for clockwise shaft rotation, as viewed from the mounting face. See *Waveform Diagrams* below.
- Output Types.....Open Collector- 100 mA max per channel
Pull-Up- 100 mA max per channel
Push-Pull- 20 mA max per channel
Line Driver- 20 mA max per channel (Meets RS 422 at 5 VDC supply)
- IndexOnce per revolution.
0475 to 4096 CPR: Gated to output A
0001 to 0474 CPR: Ungated
See *Waveform Diagrams* below.
- Freq. Response.....200 kHz
- Noise Immunity.....Tested to BS EN61000-4-2; IEC801-3; BS EN61000-4-4; DDENV 50141; DDENV 50204; BS EN55022 (with European compliance option); BS EN61000-6-2; BS EN50081-2
- Symmetry180° (±18°) electrical
- Quad. Phasing.....90° (±22.5°) electrical
- Min. Edge Sep.....67.5° electrical
- Rise Time.....Less than 1 microsecond

Mechanical

- Max Shaft Speed.....6000 RPM. Higher shaft speeds may be achievable, contact Customer Service.
- Bore Size.....0.625", 0.750", 0.875", 1.000", 14 mm, 19 mm, 24 mm, 1.125", 1.250", 1.375", 25 mm, 28 mm, 30 mm, 32 mm
Note: Bore sizes 1.125", 1.250", 1.375", 25 mm, 28 mm, 30 mm, 32 mm are clamp style. All others are collet style.
- User Shaft Tolerances
Radial Runout0.005"
Axial Endplay±0.030" with appropriate flex mount
- Moment of Inertia.....3.3 X 10⁻³ oz-in-sec² typical
- Electrical ConnGland nut with 24" cable (foil and braid shield, 24 AWG conductors). 6-, 7-, or 10-pin MS Style, 5- or 8-pin M12 (12 mm), 9-pin D-sub-miniature
- Housing.....All metal construction
- Mounting.....Thru-Bore with collet clamp or single-screw clamp mount
- Weight.....1.0 lb with gland nut or D-sub connector option
1.5 lb with MS connector option
Note: All weights typical

Environmental

- Operating Temp.....0° to 70° C for standard models
0° to 100° C for high temperature option
- Storage Temp.....-25° to 100° C
- Humidity.....98% RH non-condensing
- Vibration.....10 g @ 58 to 500 Hz
- Shock.....50 g @ 11 ms duration
- Sealing.....IP50

Model 775 Collet Clamp (A, B, C, D, H, I, K)

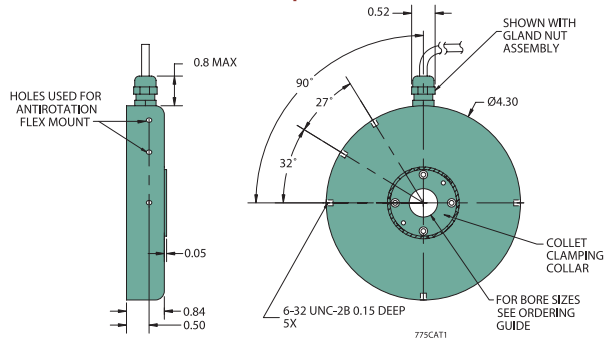

Model 775 Clamp Style (O, T, V, M, L, Q)

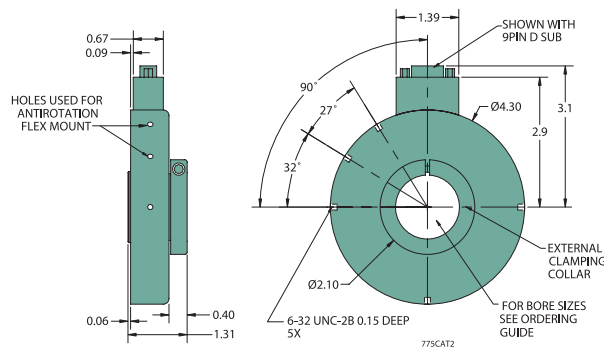

Model 775 Extended Housing (W, X, Y, J, K)

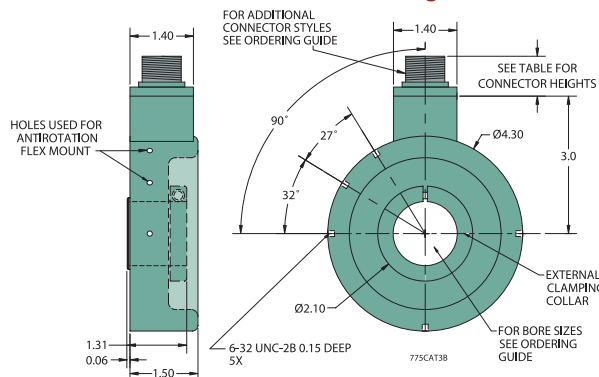

CONNECTOR TYPE	HEIGHT
6- or 7-PIN MS	0.67"
10-PIN MS	0.90"
5- or 8-PIN M12	0.50"



All dimensions are in inches with a tolerance of ±0.005" or ±0.01" unless otherwise specified

Waveform Diagrams

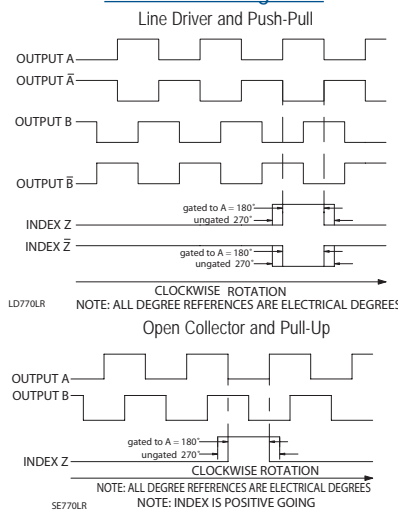

Wiring Table

Function	Gland Cable Wire Color	5-pin M12 ⁴ PU, PP, OC	8-pin M12 ⁴	10-pin MS	7-pin MS HV	7-pin MS PU, PP, OC	6-pin MS PU, PP, OC	9-pin D-sub
Com	Black	3	7	F	F	F	A, F	9
+VDC	Red	1	2	D	D	D	B	1
A	White	4	1	A	A	A	D	2
A'	Brown	---	3	H	C	---	---	3
B	Blue	2	4	B	B	B	E	4
B'	Violet	---	5	I	E	---	---	5
Z	Orange	5	6	C	---	C	C	6
Z'	Yellow	---	8	J	---	---	---	7
Shield	Bare ¹	---	---	---	---	---	---	---
Case	---	---	---	G ²	G ²	G ²	---	8 ³

¹CE Option: Cable shield (bare wire) is connected to internal Case

²CE Option: Pin G is connected to Case

Non CE Option: Pin G has No Connection

³CE Option: Pin 8 is connected to Case

Non CE Option: Pin 8 has No Connection

⁴CE Option: Read Technical Bulletin "TB111" at www.encoder.com