

# Model 758



## Features

- Standard Size 58 Mounting (58 mm Diameter)
- Up to 30,000 CPR
- 80 lb Max. Axial and Radial Shaft Loading
- High Temperature Option (100° C)
- IP66 Sealing Available

The Model 758 Size 58 Accu-Coder™ is a heavy duty, extremely rugged, reliable, yet compact European standard 58 millimeter diameter encoder, designed for harsh factory and plant floor environments. Shaft loading is no problem for the double-shielded ball bearings; their 80 lb load rating ensures a long operating life. With the optional heavy-duty shaft seal, the Model 758 is rated IP66 (NEMA 4 & 13). Two European standard mounting options are available: Clamping Flange (20 type) or Synchro Flange (26 type). The Model 758 is the perfect replacement encoder for units requiring the European mount.

## Common Applications

Motion Control Feedback, Machine & Elevator Controls, Food Processing, Robotics, Material Handling, Conveyors, Textile Machines

## Model 758 Ordering Guide

Blue type indicates price adder options. Not all configuration combinations may be available. Contact Customer Service for details.

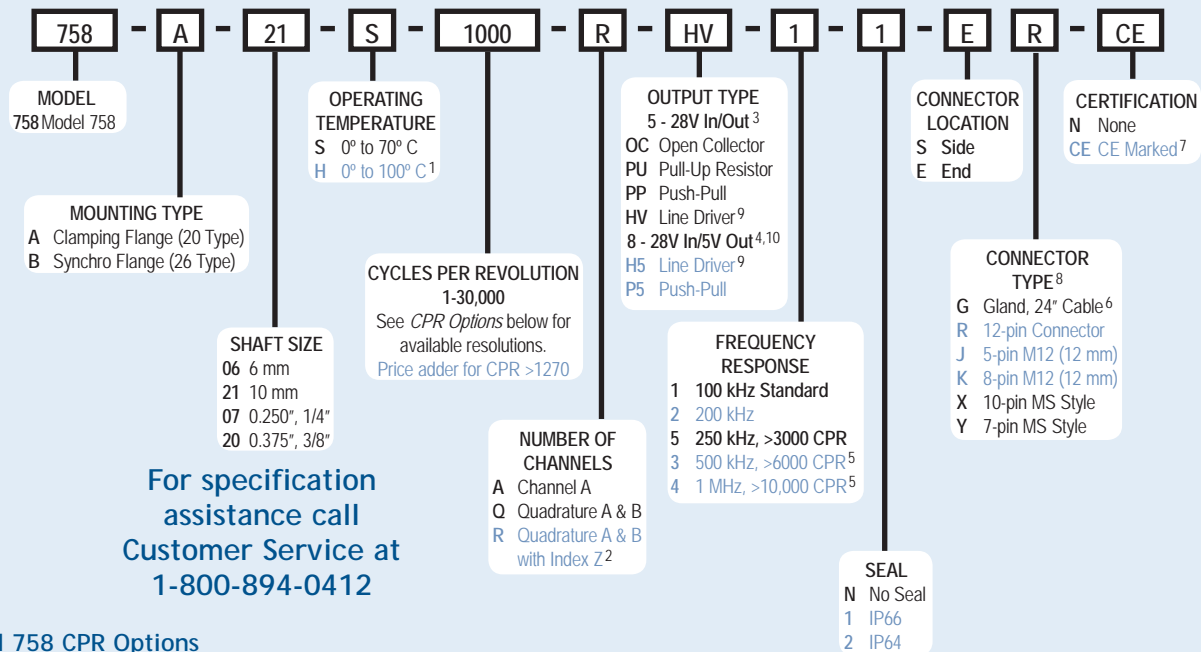

For specification assistance call  
 Customer Service at  
 1-800-894-0412

### Model 758 CPR Options

0001*	0002*	0004*	0005*	0006*	0007*	0008*	0010*	0011*
0012*	0014*	0020	0021*	0024*	0025*	0028*	0030*	0032*
0033*	0034*	0035*	0038*	0040*	0042*	0045*	0050*	0060
0064*	0100	0120	0125	0128*	0144*	0150*	0160*	0200
0240*	0250	0254*	0256*	0300	0333*	0360	0400	0500
0512	0600	0625*	0635	0665*	0720	0768*	0800	0889
0900*	1000	1024	1200	1201** <sup>a</sup>	1203** <sup>a</sup>	1204** <sup>a</sup>	1250 <sup>a</sup>	1270 <sup>a</sup>
1440	1500	1800	2000	2048	2400 <sup>a</sup>	2500	2540 <sup>a</sup>	2880 <sup>a</sup>
3000 <sup>a</sup>	3600 <sup>a</sup>	4000 <sup>a</sup>	4096 <sup>a</sup>	5000 <sup>a</sup>	6000 <sup>a</sup>	7200 <sup>a</sup>	7500 <sup>a</sup>	9000 <sup>a</sup>
10,000 <sup>a</sup>	10,240 <sup>a</sup>	12,000 <sup>a</sup>	12,500 <sup>a</sup>	14,400 <sup>a</sup>	15,000 <sup>a</sup>	18,000 <sup>a</sup>	20,000 <sup>a</sup>	20,480 <sup>a</sup>
25,000 <sup>a</sup>	30,000 <sup>a</sup>							

\* Contact Customer Service for High Temperature Option.

<sup>a</sup> High Temperature Option (H) limited to 85° C maximum for these CPR options.

New CPR values are periodically added to those listed. Contact Customer Service to determine all currently available CPR values. Special disk resolutions are available upon request. A one-time NRE fee may apply.

### NOTES:

- 1 0° to 85° C for certain resolutions, see CPR Options.
- 2 Contact Customer Service for [index gating options](#).
- 3 24 VDC max for high temperature option.
- 4 Standard temperature, 60 to 3000 CPR only.
- 5 Standard cable lengths only. For details, please refer to [Technical Bulletin TB116: Noise and Signal Considerations](#) at [www.encoder.com](http://www.encoder.com).
- 6 For Non-Standard Cable Lengths add a forward slash (/) plus cable length expressed in feet. Example: SG/6 = 6 feet of cable.
- 7 Please refer to [Technical Bulletin TB100: When to Choose the CE Option](#).
- 8 For mating connectors, cables, and cordsets, see Electrical Accessories on the web at [www.encoder.com](http://www.encoder.com).
- 9 Not available with 5-pin M12 connector. Available with 7-pin MS Type Connector only without Index Z.
- 10 H5 and P5 outputs are not available with CE option, or any End Mount MS Connector

# Model 758

## Model 758 Specifications

### Electrical

Input Voltage.....4.75 to 28 VDC max for temperatures up to 70° C  
 4.75 to 24 VDC for temperatures between 70° C to 100° C

Input Current.....100 mA max with no output load

Input Ripple .....100 mV peak-to-peak at 0 to 100 kHz

Output Format .....Incremental- Two square waves in quadrature with channel A leading B for clockwise shaft rotation, as viewed from the encoder mounting face. See *Waveform Diagrams* below.

Output Types.....Open Collector- 100 mA max per channel  
 Pull-Up- 100 mA max per channel  
 Push-Pull- 20 mA max per channel  
 Line Driver- 20 mA max per channel (Meets RS 422 at 5 VDC supply)

Index .....Occurs once per revolution. The index for units >3000 CPR is 90° gated to Outputs A and B. See *Waveform Diagrams* below.

Freq Response.....Up to 1 MHz

Noise Immunity.....Tested to BS EN61000-4-2; IEC801-3; BS EN61000-4-4; DDENV 50141; DDENV 50204; BS EN55022 (with European compliance option); BS EN61000-6-2; BS EN50081-2

Symmetry .....1 to 6000 CPR: 180° (±18°) electrical at 100 kHz output  
 6001 to 20,480 CPR: 180° (±36°) electrical

Quad Phasing.....1 to 6000 CPR: 90° (±22.5°) electrical at 100 kHz output  
 6001 to 20,480 CPR: 90° (±36°)

Min Edge Sep.....1 to 6000 CPR: 67.5° electrical at 100 kHz output  
 6001 to 20,480 CPR: 54° electrical  
 >20,480 CPR: 50° electrical

Rise Time.....Less than 1 microsecond

Accuracy.....Instrument and Quadrature Error: For 200 to 1999 CPR, 0.017° mechanical (1.0 arc minutes) from one cycle to any other cycle. For 2000 to 3000 CPR, 0.01° mechanical (0.6 arc minutes) from one cycle to any other cycle. Interpolation error (units > 3000 CPR only) within 0.005° mechanical. (Total Optical Encoder Error = Instrument + Quadrature + Interpolation)

### Mechanical

Max Shaft Speed.....8000 RPM. Higher shaft speeds may be achievable, contact Customer Service.

Shaft Size .....0.250", or 0.375", 6 mm, 10 mm

Shaft Rotation.....Bi-directional

Radial Shaft Load.....80 lb max. Rated load of 20 to 40 lb for bearing life of  $1.5 \times 10^9$  revolutions

Axial Shaft Load.....80 lb max. Rated load of 20 to 40 lb for bearing life of  $1.5 \times 10^9$  revolutions

Starting Torque.....1.0 oz-in typical with IP64 seal or no seal  
 3.0 oz-in typical with IP66 shaft seal

Moment of Inertia..... $5.2 \times 10^{-4}$  oz-in-sec<sup>2</sup>

Max. Acceleration..... $1 \times 10^5$  rad/sec<sup>2</sup>

Electrical Conn .....Gland with 24" cable (foil and braid shield, 24 AWG conductors) 7- or 10-pin MS Style, 12-pin connector, 5- or 8-pin M12 (12 mm)

Housing.....Black non-corrosive finish

Bearings.....Precision ABEC ball bearings

Mounting.....European Standard Clamping Flange (20 Type) and Synchro Flange (26 Type)

Weight.....11 oz typical

### Environmental

Operating Temp.....0° to 70° C for standard models  
 0° to 100° C for high temperature option (0° to 85° C for certain resolutions, see CPR Options.)

Storage Temp.....-25° to +85° C

Humidity.....98% RH non-condensing

Vibration.....20 g @ 58 to 500 Hz

Shock.....75 g @ 11 ms duration

Sealing.....IP66 (NEMA 13 and 4/4X) shaft seal or IP64 shaft seal

## Model 758 Clamping Flange 20 Type (A)

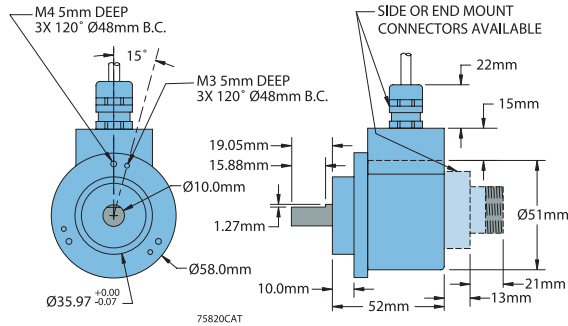

## Model 758 Synchro Flange 26 Type (B)

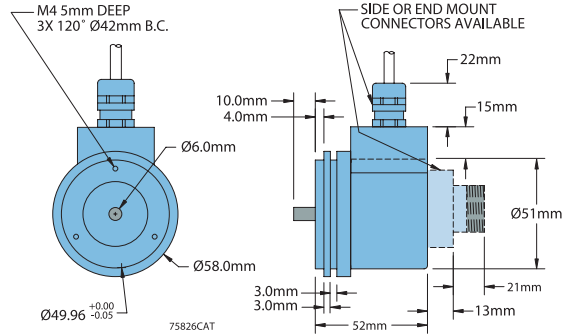

All dimensions are in millimeters with a tolerance of ±0.17 mm unless otherwise specified

### Waveform Diagrams

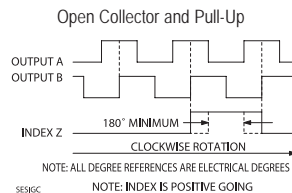
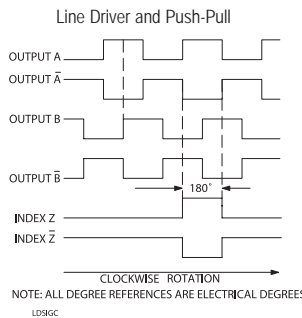

### Wiring Table

Function	Gland Cable Wire Color	5-pin M12 <sup>2</sup>	8-pin M12 <sup>2</sup>	10-pin MS	7-pin MS HV, H5	7-pin MS PP, PS, OC	12-pin
Com	Black	3	7	F	F	F	10
+VDC	Red	1	2	D	D	D	12
A	White	4	1	A	A	A	5
A'	Brown	---	3	H	C	---	6
B	Blue	2	4	B	B	B	8
B'	Violet	---	5	I	E	---	1
Z	Orange	5	6	C	---	C	3
Z'	Yellow	---	8	J	---	---	4
Shield	Bare <sup>1</sup>	---	---	---	---	---	---
+VDC Sense	---	---	---	---	---	---	2
Com Sense	---	---	---	---	---	---	11
Case	Green	---	---	G	G	G	9

<sup>1</sup>CE Option: Cable shield (bare wire) is connected to internal case  
<sup>2</sup>CE Option: Read Technical Bulletin TB111