

# Model 716 Quadrature Cube



## Features

- The Original Industry-Standard Cube
- Five Versatile Housing Styles
- Thousands of Configurations
- Many New Resolutions Available!

The Model 716 Accu-Coder™ is ideally suited for applications requiring a quadrature output. Designed for compatibility with most programmable controllers, electronic counters, motion controllers, and motor drives, it is ideally suited for industrial applications where it is important that the direction of rotation be known.

The new E-Cube™ version increases critical performance specifications for the most popular resolutions. The E-Cube™ features advanced Opto-ASIC circuitry, a single chip design that eliminates many board level components. This increases the reliability of an already dependable and durable encoder. With new options continually being added, the E-Cube™ just keeps getting better, and better!

## Common Applications

Feedback for counters, PLC's & Motors, Cut To Length, Labeling, Measuring For Packaging, Filling & Materials Handling Machines, Wire Winding, Film Extrusion

## Model 716 Ordering Guide

Blue type indicates price adder options. Not all configuration combinations may be available. Contact Customer Service for details.

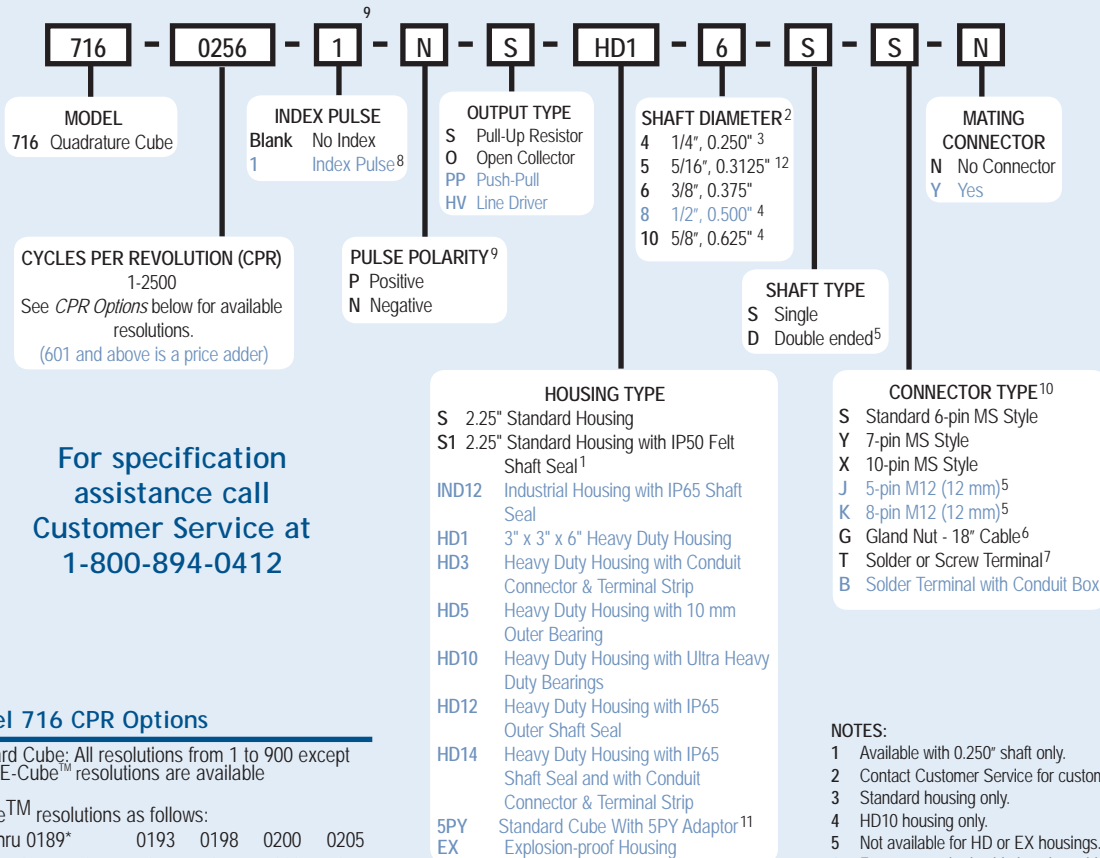

For specification assistance call Customer Service at 1-800-894-0412

## Model 716 CPR Options

Standard Cube; All resolutions from 1 to 900 except where E-Cube™ resolutions are available

E-Cube™ resolutions as follows:

0001 thru 0189*	0193	0198	0200	0205
0210	0240	0250	0256	0276
0298	0300	0305	0308	0315
0333	0336	0350	0360	0400
0480	0500	0512	0580	0597
0600	0700	0720	0800	0840
0960	1000	1024	1200	1250
1270	1800	2000	2048	2500

\*Contact Customer Service For Availability

Contact Customer Service for other disk resolutions; not all disk resolutions available with all output types

## NOTES:

- 1 Available with 0.250" shaft only.
- 2 Contact Customer Service for custom shaft lengths and diameters.
- 3 Standard housing only.
- 4 HD10 housing only.
- 5 Not available for HD or EX housings.
- 6 For non-standard cable lengths, add a forward slash (/) plus cable length expressed in feet. Example: G/6 = 6 feet of cable.
- 7 Screw terminals available for HD and EX housings. Solder terminals available for S and S1 housings.
- 8 For HV and PP Output Types, Index Pulse only available on E-Cube™.
- 9 Complete only if Index Pulse option is selected.
- 10 For Mating Connectors, Cables, and Cordsets see www.encoder.com
- 11 Only available with 5/16" (0.3125") shaft.
- 12 Standard or 5PY housing only.

# Model 716 Quadrature Cube

## Model 716 Specifications Common to All Cube Housing Styles

### Electrical

Input Voltage.....	E-Cube™- 4.75 to 28 VDC max for temperatures up to 85° C 4.75 to 24 VDC for temperatures between 85° and 100° C Standard Cube- 4.75 to 28 VDC max for temperatures up to 70° C
Input Current.....	80 mA maximum with no output load
Input Ripple.....	100 mV peak-to-peak at 0 to 100 kHz
Output Format.....	Incremental- Quadrature square wave with channel A leading B for clockwise shaft rotation
Output Types.....	Open Collector- 250 mA max per channel Pull-Up- 250 mA max per channel Push-Pull- 20 mA max per channel Line Driver- 20 mA max per channel (Meets RS 422 at 5 VDC supply)
Index.....	E-Cube™- gated to channel A, 180° electrical wide (1 to 189 CPR ungated typical 270° electrical)

Index.....	Standard Cube- Once per revolution, 180° electrical minimum non-gated
Freq Response.....	E-Cube™- 0 to 125 kHz Standard Cube- 0 to 20 kHz
Symmetry.....	180° (±18°) electrical
Quad Phasing.....	E-Cube™- 90° (±22.5°) electrical Standard Cube- 90° (±36°) electrical
Rise Time.....	Less than 1 microsecond
Accuracy.....	E-Cube™- Within 0.05° mechanical from one cycle to any other cycle, or 3 arc minutes Standard Cube- Within 0.1° mechanical from one cycle to any other cycle, or 6 arc minutes

Housing.....	Black non-corrosive finished 6063-T6 aluminum
Bearings.....	Precision ABEC Ball Bearings
Electrical Conn.....	Refer to ordering guide notes

### Environmental

Operating Temp.....	E-Cube™- 0° to 85° C or 0° to 100° C at 5 to 24 VDC Standard Cube- 0° to 70° C
Storage Temp.....	-25° to +85° C
Humidity.....	98% RH non-condensing
Vibration.....	10 g @ 58 to 500 Hz
Shock.....	50 g @ 11 ms duration

### Mechanical

Max Speed.....	6000 RPM. Higher shaft speeds achievable, contact Customer Service.
Shaft Material.....	303 stainless steel

## Standard Cube Housing (S, S1)

### Standard Cube Housing (S, S1) Specifications

#### Mechanical

Shaft Size.....	0.250" or 0.375"
Shaft Type.....	Single or double-ended (specify choice)
Radial Loading.....	15 lb maximum (0.250" diameter shaft) 40 lb maximum (0.375" diameter shaft)
Axial Loading.....	10 lb maximum (0.250" diameter shaft) 30 lb maximum (0.375" diameter shaft)
Starting Torque.....	0.13 oz-in typical for 0.250" shaft 0.38 oz-in typical for 0.375" shaft
Moment of Inertia.....	6.5 x 10 <sup>-6</sup> oz-in-sec <sup>2</sup>
Mounting.....	Tapped mounting holes on three sides for base or face mounting
Weight.....	10 oz for standard housing

Cube Housing With 1/4" Shaft (4)

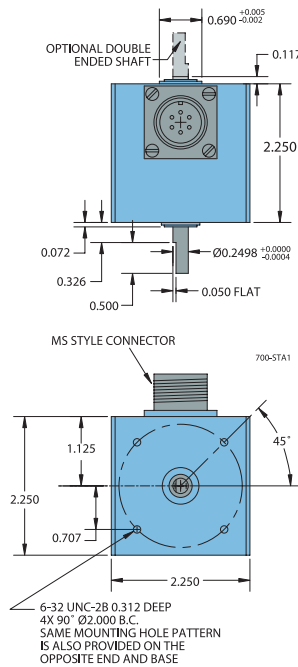

Cube Housing With 3/8" Shaft (6)

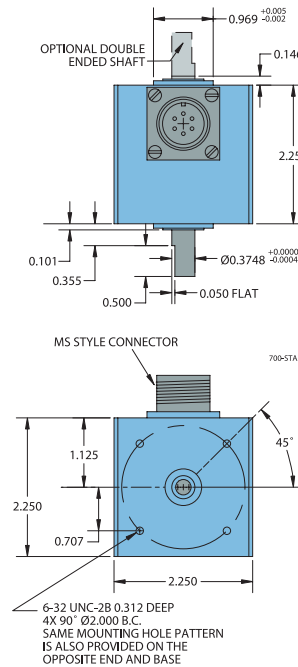

## Industrial Cube Housing (IND12)

### Industrial Housing Features

This more robust unit meets requirements between Standard and Heavy Duty housings while retaining the Cube design. The Industrial 12 (IND12) model features an IP65 shaft seal. The tough, sealed aluminum housing has a wall thickness of 0.187" and offers greater protection from wash down, sprays, dust, moisture, shock, vibration, and other hazards found in industrial environments.

### Industrial Cube Housing (IND12) Specifications

Refer to all specifications in the standard or E-Cube, unless otherwise stated:

#### Mechanical

Shaft Size.....	0.375" diameter
Shaft Type.....	Single- or Double-Ended Shaft Available
Radial Loading.....	40 lb Maximum
Axial Loading.....	30 lb Maximum
Starting Torque.....	3 oz-in Starting Torque w/IP65 Shaft Seal

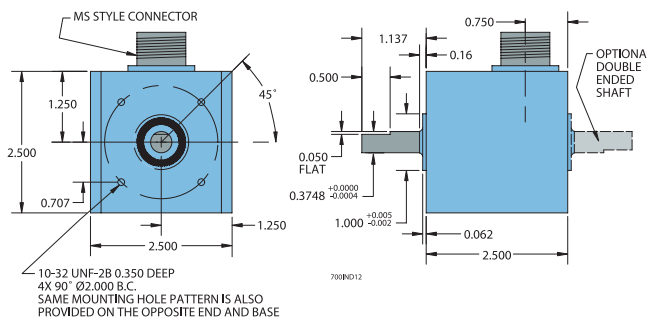

All dimensions are in inches with a tolerance of ±0.005" or ±0.01" unless otherwise specified

## Heavy Duty Cube Housing (HD12)

The Heavy Duty housing uses a separate 0.375" diameter external shaft and bearing assembly to rotate the shaft of an internally mounted Cube Housing. This provides mechanical isolation from external loads and stress. A flexible coupling between the external shaft and the encoder protects the internal unit from axial and radial loading. The 0.250" aluminum walls protect the encoder from external shock, vibration, and the outside environment.

### Heavy Duty Housing Options

- HD 1 Heavy Duty 3" X 6" housing
- HD 3 Heavy Duty w/conduit connector (threaded for 0.500" NPT Conduit) and terminal strip
- HD 5 Heavy Duty w/10 mm outer bearing
- HD 12\* Heavy Duty w/IP65 rated outer shaft seal
- HD 14\* Heavy Duty w/IP65 rated outer shaft seal, conduit connector (threaded for 0.500" NPT Conduit), and terminal strip

\* These units have an outer boss diameter of 1.000"

### Heavy Duty Cube Housing (HD12) Specifications

Refer to all cube specifications except as follows:

#### Mechanical

Max Speed .....	6000 RPM
Shaft Size .....	0.375"
Rotation .....	Either direction
Radial Loading .....	40 lb maximum (50 lb for HD 5)
Axial Loading .....	30 lb maximum (35 lb for HD 5)
Bearings .....	Precision ABEC ball bearings
Starting Torque .....	1 oz-in; 3 oz-in w/IP65 seal
Mounting .....	Tapped holes face and base
Weight .....	3.25 lb

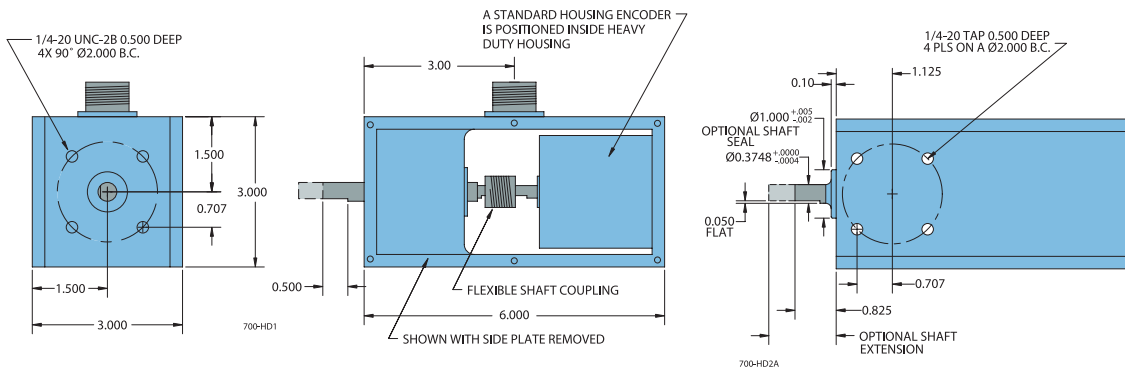

## Ultra Heavy Duty Cube Housing (HD10)

The HD 10 Ultra Heavy Duty encoder is designed for use in applications with severe shaft loading conditions. The HD 10 offers two shaft sizes: 0.500" and 0.625". Shaft material is 303 stainless steel. Bearings are conservatively rated at 95 lb radial and 60 lb axial shaft loading. IP65 shaft seal is standard on all units.

The HD 10 Ultra Heavy Duty housing uses a larger external shaft and R10 bearing assembly to rotate the shaft of an internally mounted Cube Housing. This provides mechanical isolation from external loads and stress. A flexible coupling between the external shaft and the encoder protects the internal unit from axial and radial loading. The 0.250" aluminum walls protect the encoder from external shock, vibration, and the outside environment.

### Ultra Heavy Duty Cube Housing (HD 10) Specifications

Refer to all cube specifications except as follows:

#### Mechanical

Max Speed .....	6000 RPM
Shaft Size .....	0.500" or 0.625"
Rotation .....	Either direction
Radial Loading .....	95 lb operating
Axial Loading .....	60 lb operating
Bearings .....	ABEC precision ball bearings
Bearing Life .....	15,000 hours at rated load
Starting Torque .....	3 oz-in IP65 rated
Mounting .....	Tapped holes face and base
Weight .....	3.85 lb

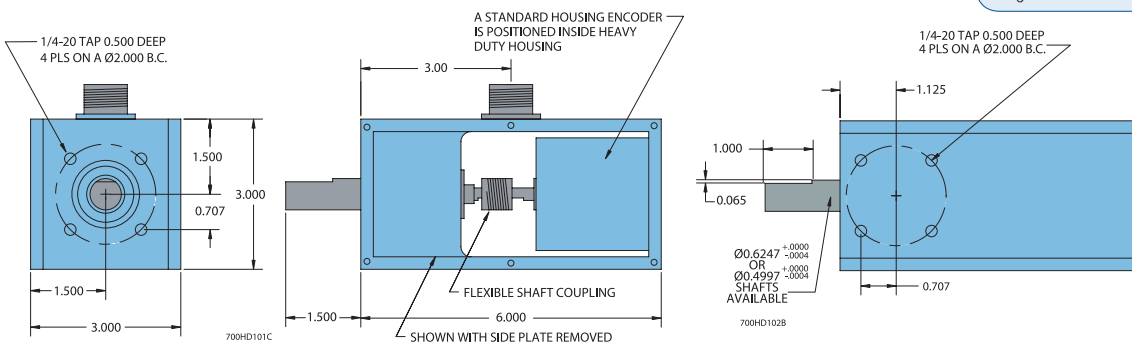

All dimensions are in inches with a tolerance of  $\pm 0.005$ " or  $\pm 0.01$ " unless otherwise specified

# Model 716 Quadrature Cube

## Explosion-Proof Housing (EX)

An explosion-proof housing is available for installing the Cube Series Accu-Coder™ in hazardous locations. The Cube Series encoder is mounted within the explosion-proof housing and is coupled to the 0.375" shaft assembly by a flexible shaft coupling. This decreases radial and axial loading on the internal encoder shaft and bearings to ensure long life. Electrical connection to the Accu-Coder™ is by an internal barrier terminal strip. A threaded hole for 0.500" NPT conduit is provided.

### Explosion-Proof Housing (EX) Specifications

The explosion-proof housing is designed to meet the following:

- NEC Class 1, Groups C and D
- NEC Class 2, Groups E, F, and G
- UL Standard 1203
- Class 1, Division 1, Groups C and D
- Class 2, Division 1, Groups E, F, and G
- CSA Standard C 22.2 No. 30-M 1986
- NEMA 7 and NEMA 9

Refer to all cube specifications except as follows:

#### Mechanical

- Max Speed ..... 4000 RPM
- Radial Loading ..... 30 lb operating
- Axial Loading ..... 10 lb operating
- Weight ..... 6 lb
- Finish ..... Unpainted Aluminum

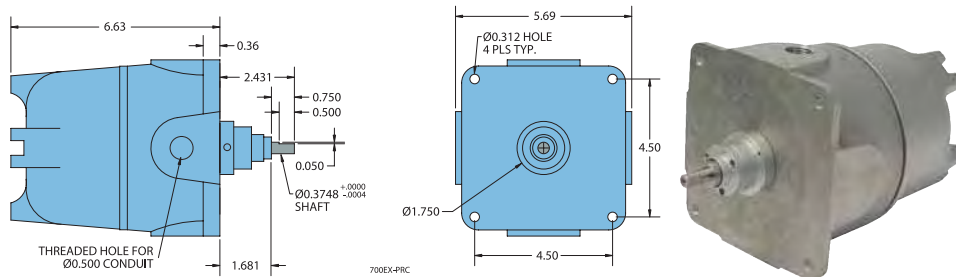

## Cube Series Optional 5PY Adapter (175443)

The all aluminum optional 5PY adapter allows any standard housing Cube Series encoder to replace DC tachometer technology. The 5PY adapter is interchangeable with any 5PY tach generator.

### Ordering Information

Order standard housing Cube Series Accu-Coder™ with 5/16" shaft and specify Accessory Part #175443. 5PY adapter kit includes all necessary hardware to attach the adapter to the encoder.

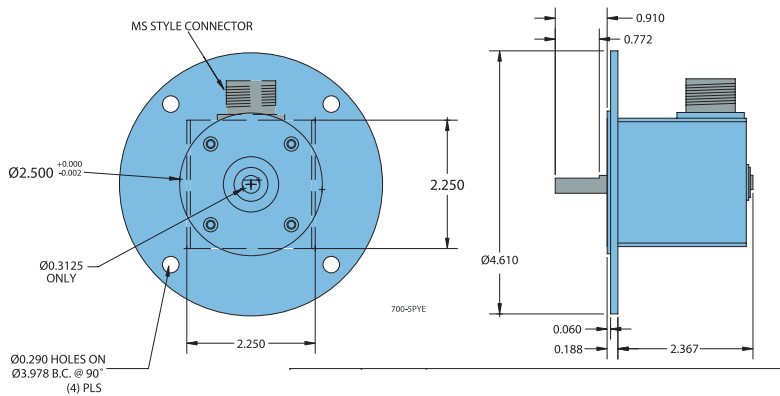

All dimensions are in inches with a tolerance of  $\pm 0.005"$  or  $\pm 0.01"$  unless otherwise specified

### Waveform Diagrams

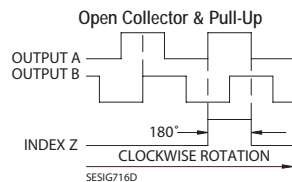
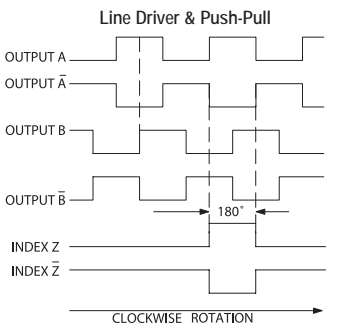

NOTE: ALL DEGREE REFERENCES ARE ELECTRICAL DEGREES  
 LDSIG

### Wiring Table

Function	Gland Cable Wire Color	5-pin M12	8-pin M12	10-pin MS	7-pin MS HV	7-pin MS O, S PP	6-pin MS HV No Index	6-pin MS O, S PP	Term. Block HV No Index	Term. Block O, S PP
Com	Black	3	7	F	F	F	A	A, F	1	1, 6
+VDC	Red	1	2	D	D	D	B	B	2	2
A	White	4	1	A	A	A	C	D	3	4
A'	Brown	----	3	H	C	----	D	----	4	----
B	Blue	2	4	B	B	B	E	E	5	5
B'	Violet	----	5	I	E	----	F	----	6	----
Z	Orange	5	6	C	----	C	----	C	----	3
Z'	Yellow	----	8	J	----	----	----	----	----	----
Case	Green <sup>1</sup>	----	----	G	G	G	----	----	----	----
Shield	Bare	----	----	----	----	----	----	----	----	----

<sup>1</sup>E-Cube Only