

# Model 25T Thru-Bore, or Model 25H Hollow Bore (Blind)



## Features

- 2.5" Opto-ASIC Encoder with a Low Profile (2.0")
- Bore Sizes Ranging From 0.625" to 1.125"
- Single Replacement Solution For 2.0" to 3.5" Encoder
- Resolutions to 10,000 CPR; Frequencies to 1 MHz
- Versatile Flexible Mounting Options
- RoHS Compliant



Introducing the next generation of high performance encoders - the Model 25T. As contemporary as its appearance, the Model 25T features the largest thru-bore available in a 2.5" encoder, mounting directly on shafts as large as 1.125" (28 mm). With resolutions of up to 10,000 CPR, and Frequencies of up to 1MHz this industrial strength encoder is perfect for fast revving motors. The 25T features the next generation of EPC's proprietary Opto-ASIC sensor which provides superior accuracy and precision counts. The injection molded housing, made from EPC's custom blend of nylon composites, is grooved with "cooling fins" and can take the extreme heat of the motion control industry. With sealing available of up to IP66 and many new rugged flexible mounting options, the Model 25T can perform in demanding industrial environments. This revolutionary new 2.5" encoder truly is unlike any other.

## Common Applications

Motor-Mounted Feedback and Vector Control, Specialty Machines, Robotics, Web Process Control, Paper and Printing, High Power Motors

## Model 25T/H Ordering Guide

Blue type indicates price adder options. Not all configuration combinations may be available. Contact Customer Service for details.

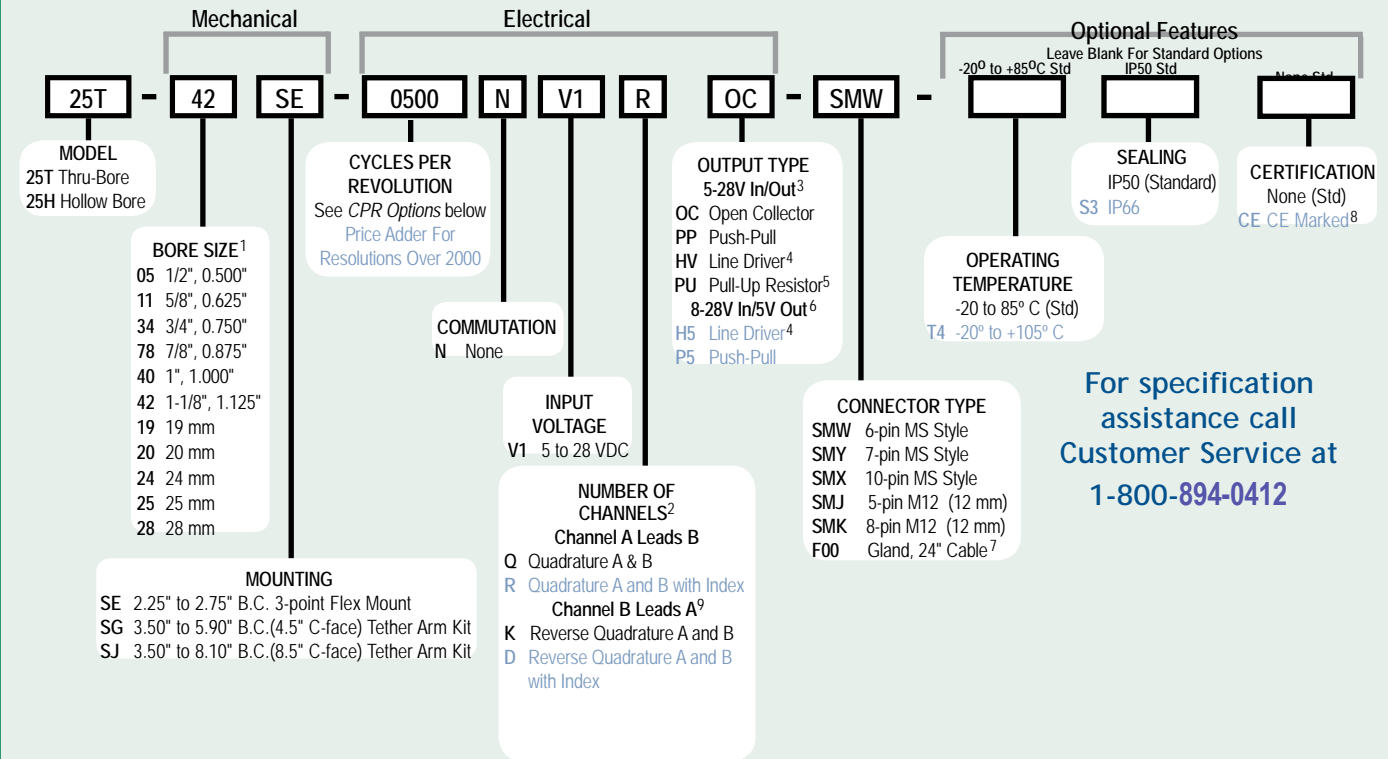

For specification assistance call  
Customer Service at  
**1-800-894-0412**

## Model 25T/H CPR Options

0010	0060	0100	0120	0240	0250	0256
0300	0360	0500	0512	0600	1000	1024
1200	2000	2048	2500	4096	5000	10,000

Contact Customer Service for other disk resolutions.

## NOTES:

- 1 Contact Customer Service for additional options.
- 2 Contact Customer Service for non-standard index gating options.
- 3 24 VDC max for T4 temperature option.
- 4 Not available with 5-pin M12 or 6-pin MS style connectors. Available with 7-pin MS style connector without index Z.
- 5 With Input Voltage above 16 VDC, operating temperature is limited to 85° C max.
- 6 Standard operating temperature only.
- 7 For non-standard English cable lengths enter 'F' plus cable length expressed in feet. Example: F06 = 6 feet of cable.
- 8 Please refer to Technical Bulletin TB100: *When to Choose the CE Option* at [www.encoder.com](http://www.encoder.com). Contact Customer Service for availability.
- 9 Not available with Pull-Up Output Type.

# Model 25T Thru-Bore, or Model 25H Hollow Bore (Blind)



## Model 25T/H Specifications

### Electrical

- Input Voltage.....4.75 to 28 VDC max for temperatures up to 85° C  
4.75 to 24 VDC max for temperatures between 85° and 105° C
- Input Current.....100 mA max with no output load
- Output Format.....Incremental- Two square waves in quadrature with channel A leading B for clockwise shaft rotation, as viewed from the mounting face.  
See *Waveform Diagram*.
- Output Types.....Open Collector- 20 mA max per channel  
Pull Up - Open Collector with 2.2K ohm resistor, 20 mA max per channel  
Push-Pull- 20 mA max per channel  
Line Driver- 20 mA max per channel (Meets RS 422 at 5 VDC supply)
- Index.....Once per revolution.  
361 to 10,000 CPR: Gated to output A  
1 to 360 CPR: Ungated  
See *Waveform Diagram*.
- Max Frequency.....250 kHz for 1 to 2500 CPR  
500 kHz for 2501 to 5000 CPR  
1 MHz for 5001 to 10,000 CPR
- CE Testing.....Emissions tested per EN61000-6-3:2001 as applicable. Immunity tested per EN6100-6-2:2005 as applicable
- Min. Edge Sep.....45° electrical min, 63° electrical or better typical
- Rise Time.....Less than 1 microsecond
- Accuracy.....Within 0.1° mechanical from one cycle to any other cycle, or 6 arc minutes.

### Mechanical

- Max Shaft Speed.....6000 RPM, 8000 RPM intermittent  
4000 RPM for IP66 seal option
- Bore Size.....0.625" through 1.125"  
19 mm through 28 mm
- Bore Tolerance.....-0.0000"/+0.0008"
- User Shaft Tolerances  
Radial Runout.....0.005" max  
Axial Endplay.....±0.050" max
- Starting Torque.....IP50 sealing: 1.0 oz-in typical  
IP66 sealing: 4.0 oz-in typical  
Note: Add 1.0 oz-in typical for -20° C operation
- Moment of Inertia..... $7.6 \times 10^{-4}$  oz-in-sec<sup>2</sup>
- Max Acceleration..... $1 \times 10^5$  rad/sec<sup>2</sup>
- Electrical Conn.....6-, 7-, or 10-pin MS Style, 5- or 8-pin M12 (12 mm) or gland with 24 inches of cable (foil and braid shield, 24 AWG conductors)
- Housing.....Proprietary nylon composite
- Mounting.....2.25" to 2.75" B.C. 3-point flex mount  
3.50" to 5.90" B.C. (4.5" C-face) tether arm kit  
3.50" to 8.10" B.C. (8.5" C-face) tether arm kit  
See mechanical drawing for dimensions
- Weight.....8 oz typical

### Environmental

- Operating Temp.....-20° to 85° C for standard models  
-20° to 105° C for high temperature option
- Storage Temp.....-20° to +85° C
- Humidity.....98% RH non-condensing
- Vibration.....20 g @ 5 to 2000 Hz
- Shock.....80 g @ 11 ms duration
- Sealing.....IP50, IP66 with shaft seals at both ends

## Model 25T/H

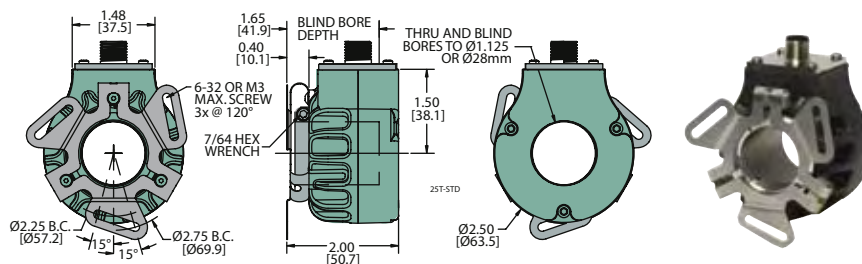

## Model 25T/H Connector Options

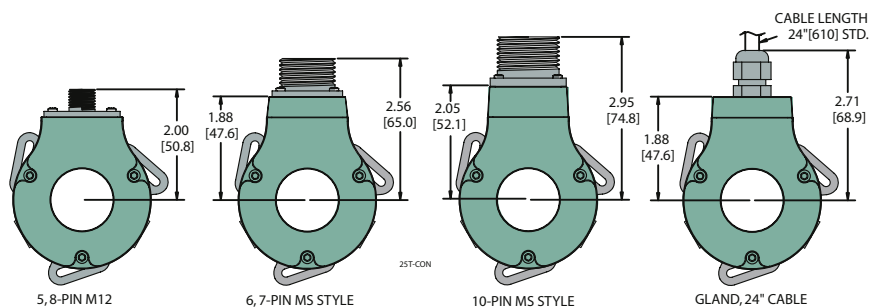

## Model 25T/H Tether Arm Kit Options

### SG Mount

### SJ Mount

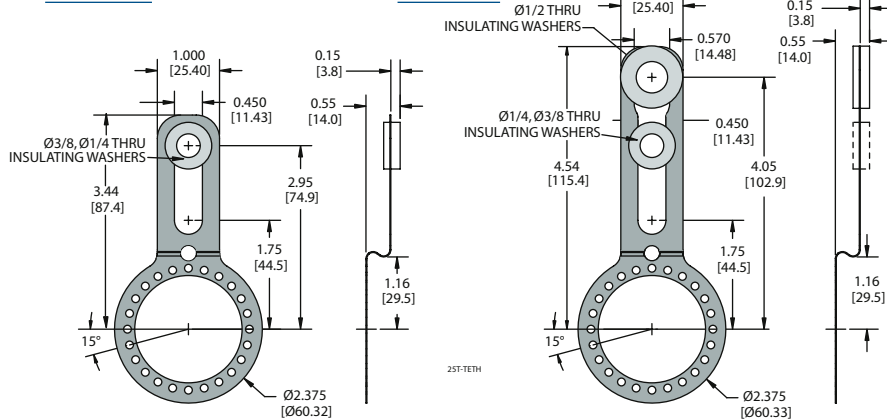

All dimensions are in inches with a tolerance of  $\pm 0.005"$  or  $\pm 0.01"$  unless otherwise specified

## Waveform Diagram

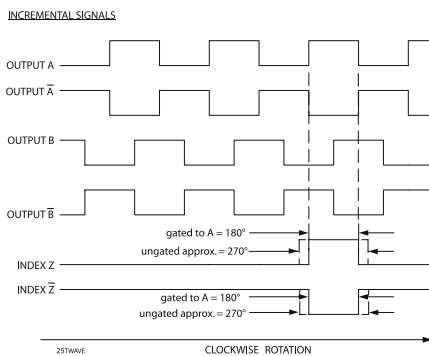

NOTE: ALL DEGREE REFERENCES ARE ELECTRICAL DEGREES

## Wiring Table

Function	Gland Cable Wire Color	5-pin M12 <sup>1</sup>	8-pin M12 <sup>2</sup>	10-pin MS	7-pin MS HV, H5	7-pin MS PU, PP, OC, P5	6-pin MS PU, PP, OC, P5
Com	Black	3	7	F	F	F	A, F
+VDC	White	1	2	D	D	D	B
A	Brown	4	1	A	A	A	D
A'	Yellow	---	3	H	C	---	---
B	Red	2	4	B	B	B	E
B'	Green	---	5	I	E	---	---
Z	Orange	5	6	C	---	C	C
Z'	Blue	---	8	J	---	---	---
Case	---	---	---	G	G	G	---
Shield	Bare <sup>1</sup>	---	---	---	---	---	---

<sup>1</sup>CE Option: Cable shield (bare wire) is connected to internal case  
<sup>2</sup>CE Option: Read Technical Bulletin TB111