

# AC Tech

a member of the **Lenze** Group

Drive for Global Excellence



## SCD Series Installation and Operation Manual

## TABLE OF CONTENTS

1.0	GENERAL.....	1
2.0	SCD DIMENSIONS.....	2
	THROUGH-HOLE MOUNT DIMENSIONS.....	4
3.0	SCD MODEL DESIGNATION CODE.....	5
4.0	SCD SPECIFICATIONS.....	6
5.0	SCD RATINGS.....	7
6.0	INSTALLATION.....	9
7.0	INPUT AC POWER REQUIREMENTS.....	10
8.0	POWER WIRING.....	13
9.0	SCD POWER WIRING DIAGRAM.....	14
10.0	CONTROL WIRING.....	15
11.0	SCD CONTROL WIRING DIAGRAMS.....	18
12.0	INITIAL POWER UP AND MOTOR ROTATION.....	23
13.0	PROGRAMMING THE SCD DRIVE.....	25
14.0	PARAMETER MENU.....	29
15.0	DESCRIPTION OF PARAMETERS.....	33
16.0	TROUBLESHOOTING.....	49
17.0	SCD DISPLAY MESSAGES.....	51
	APPENDIX A - THROUGH-HOLE MOUNT OPTION.....	53
	APPENDIX B - DEVICENET™ CONTROL.....	57

DeviceNet is a Trademark of the Open DeviceNet Vendor Association, Inc.

# THE SCD SUB-MICRO DRIVE

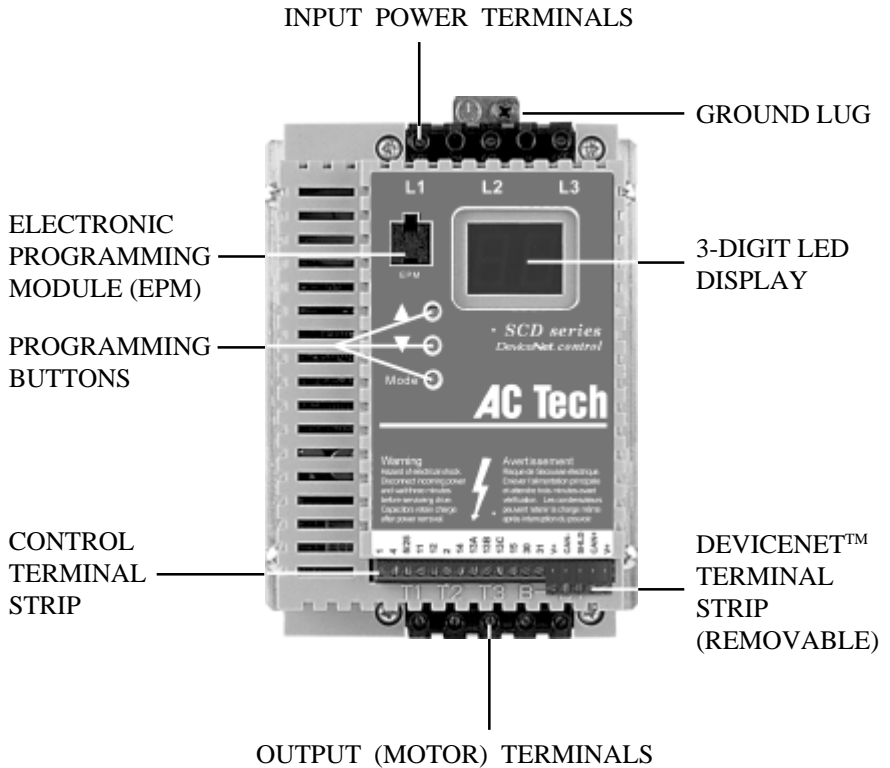

## 1.0 GENERAL

### 1.1 PRODUCTS COVERED IN THIS MANUAL

This manual covers the AC Tech SCD Series Variable Frequency Drive.

### 1.2 PRODUCT CHANGES

AC Technology Corporation reserves the right to discontinue or make modifications to the design of its products without prior notice, and holds no obligation to make modifications to products sold previously. AC Technology Corporation also holds no liability for losses of any kind which may result from this action.

### 1.3 WARRANTY

AC Technology Corporation warrants the SCD Series AC motor control to be free of defects in material and workmanship for a period of twelve months from the date of sale to the user, or eighteen months from the date of shipment, whichever ever occurs first. If an SCD motor control, under normal use, becomes defective within the stated warranty time period, contact AC Technology's Service Department for instructions on obtaining a warranty replacement unit. AC Technology Corporation reserves the right to make the final determination as to the validity of a warranty claim, and sole obligation is to repair or replace only components which have been rendered defective due to faulty material or workmanship. No warranty claim will be accepted for components which have been damaged due to mishandling, improper installation, unauthorized repair and/or alteration of the product, operation in excess of design specifications or other misuse, or improper maintenance. AC Technology Corporation makes no warranty that its products are compatible with any other equipment, or to any specific application, to which they may be applied and shall not be held liable for any other consequential damage or injury arising from the use of its products.

**This warranty is in lieu of all other warranties, expressed or implied. No other person, firm or corporation is authorized to assume, for AC Technology Corporation, any other liability in connection with the demonstration or sale of its products.**

### 1.4 RECEIVING

Inspect all cartons for damage which may have occurred during shipping. Carefully unpack equipment and inspect thoroughly for damage or shortage. Report any damage to carrier and/or shortages to supplier. All major components and connections should be examined for damage and tightness, with special attention given to PC boards, plugs, knobs and switches.

### 1.5 CUSTOMER MODIFICATION

AC Technology Corporation, its sales representatives and distributors, welcome the opportunity to assist our customers in applying our products. Many customizing options are available to aid in this function. AC Technology Corporation cannot assume responsibility for any modifications not authorized by its engineering department.

## 2.0 SCD DIMENSIONS

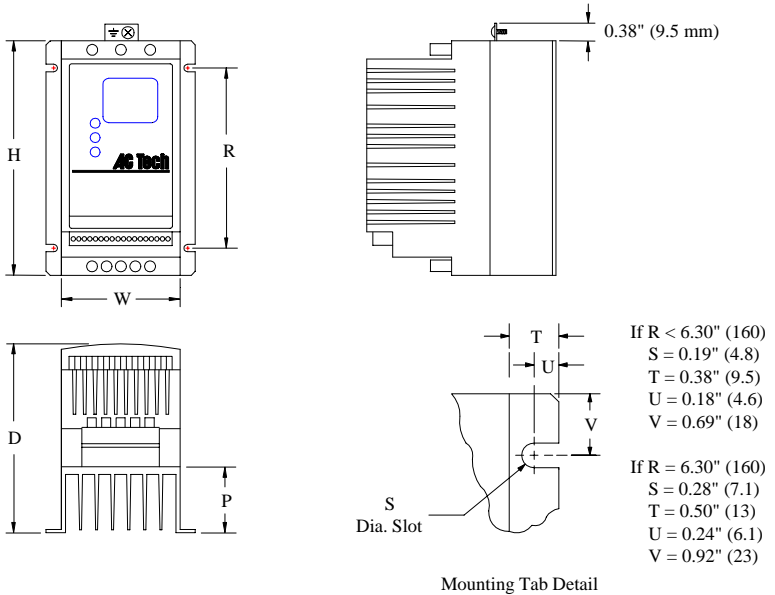

		INPUT							
HP	KW	VOLTAGE	MODEL	H	W	D	P	R	
0.25	0.18	208/240	SD203Y	5.75 (146)	2.88 (73)	3.94 (100)	0.80 (20)	4.37 (111)	
0.5	0.37	208/240	SD205Y	5.75 (146)	2.88 (73)	3.94 (100)	0.80 (20)	4.37 (111)	
			400/480	SD405	5.75 (146)	2.88 (73)	3.94 (100)	0.80 (20)	4.37 (111)
1	0.75	208/240	SD210Y	5.75 (146)	2.88 (73)	4.74 (120)	1.60 (41)	4.37 (111)	
			SD210	5.75 (146)	2.88 (73)	4.74 (120)	1.60 (41)	4.37 (111)	
		400/480	SD410	5.75 (146)	2.88 (73)	4.74 (120)	1.60 (41)	4.37 (111)	
			SD510	5.75 (146)	2.88 (73)	4.74 (120)	1.60 (41)	4.37 (111)	
1.5	1.1	208/240	SD215Y	5.75 (146)	3.76 (96)	5.24 (133)	1.90 (48)	4.37 (111)	
			SD215	5.75 (146)	2.88 (73)	5.74 (146)	2.60 (66)	4.37 (111)	
		400/480	SD415	5.75 (146)	2.88 (73)	5.74 (146)	2.60 (66)	4.37 (111)	
2	1.5	208/240	SD220Y	5.75 (146)	3.76 (96)	6.74 (171)	3.40 (86)	4.37 (111)	
			SD220	5.75 (146)	2.88 (73)	5.74 (146)	2.60 (66)	4.37 (111)	
		400/480	SD420	5.75 (146)	2.88 (73)	5.74 (146)	2.60 (66)	4.37 (111)	
			SD520	5.75 (146)	2.88 (73)	5.74 (146)	2.60 (66)	4.37 (111)	

INPUT								
HP	KW	VOLTAGE	MODEL	H	W	D	P	R
3	2.2	208/240	SD230Y	5.75 (146)	3.76 (96)	6.74 (171)	3.40 (86)	3.25 (83)
		208/240	SD230	5.75 (146)	2.88 (73)	5.74 (146)	2.60 (66)	3.06 (78)
		400/480	SD430	5.75 (146)	2.88 (73)	5.74 (146)	2.60 (66)	3.06 (78)
		480/590	SD530	5.75 (146)	3.76 (96)	6.74 (171)	3.40 (86)	4.37 (111)
5	3.7	208/240	SD250Y	7.75 (197)	5.02 (128)	7.18 (182)	3.40 (86)	4.81 (122)
		208/240	SD250	5.75 (146)	3.76 (96)	6.74 (171)	3.40 (86)	3.25 (83)
		400/480	SD450	5.75 (146)	3.76 (96)	6.74 (171)	3.40 (86)	3.25 (83)
		480/590	SD550	5.75 (146)	3.76 (96)	6.74 (171)	3.40 (86)	3.25 (83)
7.5	5.5	208/240	SD275	7.75 (197)	5.02 (128)	7.18 (182)	3.40 (86)	4.81 (122)
		400/480	SD475	7.75 (197)	5.02 (128)	7.18 (182)	3.40 (86)	4.81 (122)
		480/590	SD575	7.75 (197)	5.02 (128)	7.18 (182)	3.40 (86)	4.81 (122)
10	7.5	208/240	SD2100	7.75 (197)	5.02 (128)	7.18 (182)	3.40 (86)	4.81 (122)
		400/480	SD4100	7.75 (197)	5.02 (128)	7.18 (182)	3.40 (86)	4.81 (122)
		480/590	SD5100	7.75 (197)	5.02 (128)	7.18 (182)	3.40 (86)	4.81 (122)
15	11	208/240	SD2150	9.75 (248)	6.68 (170)	8.00 (203)	3.60 (91)	6.30 (160)
		400/480	SD4150	9.75 (248)	6.68 (170)	8.00 (203)	3.60 (91)	6.30 (160)
		480/590	SD5150	9.75 (248)	6.68 (170)	8.00 (203)	3.60 (91)	6.30 (160)
20	15	208/240	SD2200	9.75 (248)	6.68 (170)	8.00 (203)	3.60 (91)	6.30 (160)
		400/480	SD4200	9.75 (248)	6.68 (170)	8.00 (203)	3.60 (91)	6.30 (160)
		480/590	SD5200	9.75 (248)	6.68 (170)	8.00 (203)	3.60 (91)	6.30 (160)
25	18.5	400/480	SD4250	9.75 (248)	6.68 (170)	8.00 (203)	3.60 (91)	6.30 (160)
		480/590	SD5250	9.75 (248)	6.68 (170)	8.00 (203)	3.60 (91)	6.30 (160)

## 2.1

## SCD THROUGH-HOLE MOUNT DIMENSIONS

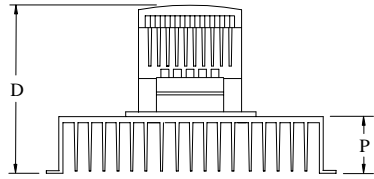
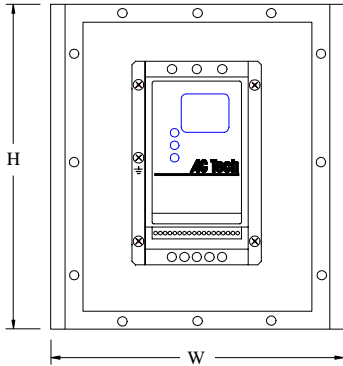

HP	KW	INPUT		H	W	D	P
		VOLTAGE	MODEL				
1	0.75	208 / 240	SD210YF	7.72 (196)	6.80 (173)	4.55 (116)	1.20 (30)
		208 / 240	SD210F	7.72 (196)	6.80 (173)	4.55 (116)	1.20 (30)
		400 / 480	SD410F	7.72 (196)	6.80 (173)	4.55 (116)	1.20 (30)
		480 / 590	SD510F	7.72 (196)	6.80 (173)	4.55 (116)	1.20 (30)
1.5	1.1	208 / 240	SD215YF	7.72 (196)	6.80 (173)	4.75 (121)	1.20 (30)
		208 / 240	SD215F	7.72 (196)	6.80 (173)	4.55 (116)	1.20 (30)
		400 / 480	SD415F	7.72 (196)	6.80 (173)	4.55 (116)	1.20 (30)
2	1.5	208 / 240	SD220YF	7.72 (196)	6.80 (173)	4.75 (121)	1.20 (30)
		208 / 240	SD220F	7.72 (196)	6.80 (173)	4.55 (116)	1.20 (30)
		400 / 480	SD420F	7.72 (196)	6.80 (173)	4.55 (116)	1.20 (30)
		480 / 590	SD520F	7.72 (196)	6.80 (173)	4.55 (116)	1.20 (30)
3	2.2	208 / 240	SD230YF	7.72 (196)	8.54 (217)	5.30 (135)	1.75 (44)
		208 / 240	SD230F	7.72 (196)	8.54 (217)	5.10 (130)	1.75 (44)
		400 / 480	SD430F	7.72 (196)	8.54 (217)	5.10 (130)	1.75 (44)
		480 / 590	SD530F	7.72 (196)	8.54 (217)	5.30 (135)	1.75 (44)
5	3.7	208 / 240	SD250YF	9.59 (244)	11.14 (283)	7.65 (194)	3.60 (91)
		208 / 240	SD250F	7.72 (196)	8.54 (217)	6.30 (160)	2.75 (70)
		400 / 480	SD450F	7.72 (196)	8.54 (217)	6.30 (160)	2.75 (70)
		480 / 590	SD550F	7.72 (196)	8.54 (217)	6.30 (160)	2.75 (70)
7.5	5.5	208 / 240	SD275F	11.59 (294)	11.14 (283)	7.65 (194)	3.60 (91)
		400 / 480	SD475F	9.59 (244)	11.14 (283)	7.65 (194)	3.60 (91)
		480 / 590	SD575F	9.59 (244)	11.14 (283)	7.65 (194)	3.60 (91)

HP	KW	INPUT					
		VOLTAGE	MODEL	H	W	D	P
10	7.5	208/240	SD2100F	15.59 (396)	11.14 (283)	7.65 (194)	3.60 (91)
		400/480	SD4100F	11.59 (294)	11.14 (283)	7.65 (194)	3.60 (91)
		480/590	SD5100F	11.59 (294)	11.14 (283)	7.65 (194)	3.60 (91)
15	11	208/240	SD2150F	18.09 (459)	11.14 (283)	8.29 (211)	3.60 (91)
		400/480	SD4150F	15.59 (396)	11.14 (283)	8.29 (211)	3.60 (91)
		480/590	SD5150F	15.59 (396)	11.14 (283)	8.29 (211)	3.60 (91)
20	15	400/480	SD4200F	18.09 (459)	11.14 (283)	8.29 (211)	3.60 (91)
		480/590	SD5200F	18.09 (459)	11.14 (283)	8.29 (211)	3.60 (91)
25	18.5	400/480	SD4250F	28.50 (724)	10.34 (263)	8.39 (213)	3.70 (94)
		480/590	SD5250F	28.50 (724)	10.34 (263)	8.39 (213)	3.70 (94)

**NOTE:** Refer to Appendix A for mounting template dimensions for the Through-hole Mount option.

### 3.0 SCD MODEL DESIGNATION CODE

The SCD model number gives a full description of the basic drive unit (see example below).

**EXAMPLE:** SD210Y (SCD Series, 208/240 Vac, 1 HP, single or three phase input)

	<b>SD</b>	<b>2</b>	<b>10</b>	<b>Y</b>	
<b>Series:</b>					
SD = SCD Series Variable Speed AC Motor Drive with DeviceNet™					
<b>Input Voltage:</b>					
2 = 208/240 Vac (For 208, 220, 230, and 240 Vac; 50 or 60 Hz)					
4 = 400/480 Vac (For 380, 415, 440, 460 and 480 Vac; 50 or 60 Hz)					
5 = 480/590 Vac (For 460, 480, 550, 575 and 600 Vac; 50 or 60 Hz)					
<b>Horsepower:</b>					
03 = ¼ Hp    15 = 1½ Hp    50 = 5 Hp    150 = 15 Hp					
05 = ½ Hp    20 = 2 Hp    75 = 7½ Hp    200 = 20 Hp					
10 = 1 Hp    30 = 3 Hp    100 = 10 Hp    250 = 25 Hp					
<b>Input: Phase:</b>					
Y = Single or three phase input					
<i>No character indicates three phase input only</i>					
<b>Mounting Style:</b>					
F = Through-hole mount with special heatsink					
F1 = Through-hole mount without heatsink (customer supplies heatsink)					
<i>No character indicates panel or DIN rail mounting</i>					
<b>Application Specific Options:</b>					
V = High Frequency Output – up to 1000 Hz					

## 4.0 SCD SPECIFICATIONS

Storage Temperature	-20 to 70 C
Ambient Operating Temperature	0 to 50 C (up to 6 kHz carrier, derate above 6 kHz)
Ambient Humidity	< 95% (non-condensing)
Maximum Altitude	3300 ft (1000 m) above sea level (without derating)
Input Line Voltages	208/240 Vac, 400/480 Vac, 480/590 Vac
Input Voltage Tolerance	+10%, -15%
Input Frequency Tolerance	48 to 62 Hz
Output Wave Form	Sine Coded PWM
Output Frequency	0 - 240 Hz (consult factory for higher output frequencies)
Carrier Frequency	4 kHz to 10 kHz
Service Factor	1.00 (up to 6 kHz carrier, derate above 6 kHz)
Efficiency	Up to 98%
Power Factor (displacement)	0.96 or better
Overload Current Capacity	150% for 60 seconds, 180% for 30 seconds
Speed Reference Follower	0-10 VDC, 4-20 mA
Control Voltage	15 VDC
Power Supply for Auxiliary Relays	50 mA at 12 VDC
Analog Outputs	0 - 10 VDC or 2 - 10 VDC: Proportional to frequency or load
Digital Outputs	Open-collector outputs: 50 mA at 30 VDC

### 4.1 DEVICENET™ ELECTRICAL SPECIFICATIONS

Supply Voltage	11 to 25 VDC
Current Consumption (max)	50 mA @ 11 VDC
Baud Rates and Max Distance	125 kbps - 500 m (1640 ft) 250 kbps - 250 m (820 ft) 500 kbps - 100 m (328 ft)

## 5.0 SCD RATINGS

MODEL NUMBER (NOTE 1)	FORMOTORS		INPUT (50-60 Hz)			OUTPUT	HEAT LOSS (WATTS) (NOTE 5)	
	RATED		INPUT PHASE	CURRENT (AMPS)	POWER (KVA)	CURRENT (AMPS)	STD	THRU
	HP	KW						
<b>SD200Y SERIES (NOTE 2)</b>			<b>208 / 240 Vac</b>			<b>0 - 200 / 230 Vac</b>		
SD203Y	0.25	0.18	1	3.6/3.2	0.76	1.6/1.4	19	N/A
SD203Y	0.25	0.18	3	1.9/1.7	0.71	1.6/1.4	19	N/A
SD205Y	0.5	0.37	1	5.4/4.7	1.2	2.5/2.2	26	N/A
SD205Y	0.5	0.37	3	3.1/2.7	1.1	2.5/2.2	26	N/A
SD210Y	1	0.75	1	10.6/9.2	2.2	4.8/4.2	49	18
SD210Y	1	0.75	3	5.8/5.1	2.1	4.8/4.2	49	18
SD215Y	1.5	1.1	1	13.9/12.0	2.9	6.9/6.0	82	23
SD215Y	1.5	1.1	3	8.0/6.9	2.9	6.9/6.0	82	23
SD220Y	2	1.5	1	14.8/12.9	3.1	7.8/6.8	86	26
SD220Y	2	1.5	3	9.1/7.9	3.2	7.8/6.8	86	26
SD230Y	3	2.2	1	19.7/17.1	4.1	11.0/9.6	130	29
SD230Y	3	2.2	3	12.4/10.8	4.4	11.0/9.6	130	29
SD250Y	5	3.7	1	29/26	6.1	17.5/15.2	212	40
SD250Y	5	3.7	3	19.6/17.1	7.1	17.5/15.2	212	40
<b>SD200 SERIES (NOTE 2)</b>			<b>208 / 240 Vac</b>			<b>0 - 200 / 230 Vac</b>		
SD210	1	0.75	3	5.8/5.1	2.1	4.8/4.2	41	11
SD215	1.5	1.1	3	8.0/6.9	2.9	6.9/6.0	69	13
SD220	2	1.5	3	9.1/7.9	3.3	7.8/6.8	78	15
SD230	3	2.2	3	12.4/10.8	4.5	11.0/9.6	117	20
SD250	5	3.7	3	19.6/17.1	7.1	17.5/15.2	187	22
SD275	7.5	5.5	3	28/25	10.3	25/22	286	31
SD2100	10	7.5	3	34/32	13.1	30/28	379	39
SD2150	15	11	3	54/48	20.0	48/42	476	51
SD2200	20	15	3	65/61	25.4	58/54	648	N/A
NOTE 1: See Section 3.0 for model number breakdown.								
NOTE 2: The higher current ratings are for 208 Vac input and the lower current ratings are for 240 Vac input.								
NOTE 5: STD = standard unit; THRU = through-hole mount unit. Values are worst-case (not typical) for 6kHz carrier frequency at full speed and full load.								

MODEL NUMBER (NOTE 1)	FOR MOTORS RATED		INPUT (50-60 Hz)			OUTPUT	HEAT LOSS (WATTS) (NOTE 5)	
	HP	kW	INPUT	CURRENT	POWER	CURRENT (AMPS)	STD	THRU
			PHASE	(AMPS)	(kVA)			
<b>SD400 SERIES (NOTE 3)</b>			<b>400 / 480 Vac</b>			<b>0 - 400 / 460 Vac</b>		
SD405	0.5	0.37	3	1.6/1.4	1.1	1.3/1.1	26	N/A
SD410	1	0.75	3	2.9/2.5	2.1	2.4/2.1	40	12
SD415	1.5	1.1	3	4.0/3.6	3.0	3.4/3.0	56	13
SD420	2	1.5	3	4.6/4.0	3.3	3.9/3.4	67	14
SD430	3	2.2	3	6.2/5.4	4.5	5.5/4.8	100	19
SD450	5	3.7	3	9.8/8.6	7.1	8.7/7.6	168	22
SD475	7.5	5.5	3	14.2/12.4	10.3	12.6/11.0	254	29
SD4100	10	7.5	3	18.1/15.8	13.1	16.1/14.0	310	37
SD4150	15	11	3	27/24	20.0	24/21	390	42
SD4200	20	15	3	35/31	25.8	31/27	530	57
SD4250	25	18.5	3	44/38	31.6	39/34	648	72
<b>SD500 SERIES (NOTE 4)</b>			<b>480 / 590 Vac</b>			<b>0 - 460 / 575 Vac</b>		
SD510	1	0.75	3	2.2/2.0	1.9/2.0	1.9/1.7	40	12
SD520	2	1.5	3	4.0/3.5	3.3/3.6	3.4/3.0	67	13
SD530	3	2.2	3	4.7/4.7	3.9/4.8	4.2/4.2	100	14
SD550	5	3.7	3	7.4/7.4	6.1/7.5	6.6/6.6	168	19
SD575	7.5	5.5	3	11.2/11.2	9.3/11.4	9.9/9.9	254	29
SD5100	10	7.5	3	13.7/13.7	11.4/14.0	12.2/12.2	310	37
SD5150	15	11	3	22/22	18.3/22.5	19.0/19.0	390	42
SD5200	20	15	3	27/27	22.4/27.6	24/24	530	57
SD5250	25	18.5	3	31/31	25.8/31.7	27/27	648	72
NOTE 1: See Section 3.0 for model number breakdown.								
NOTE 3: The higher current ratings are for 400 Vac input and the lower current ratings are for 480 Vac input.								
NOTE 4: The higher current ratings are for 480 Vac input and the lower current ratings are for 590 Vac input.								
NOTE 5: STD = standard unit; THRU = through-hole mount unit. Values are worst-case (not typical) for 6kHz carrier frequency at full speed and full load.								

## 6.0 INSTALLATION

### NOTE!

SCD drives are intended for inclusion within other equipment, by professional electrical installers. They are not intended for stand-alone operation.

### WARNING!

DRIVES MUST NOT BE INSTALLED WHERE SUBJECTED TO ADVERSE ENVIRONMENTAL CONDITIONS SUCH AS: COMBUSTIBLE, OILY, OR HAZARDOUS VAPORS OR DUST; EXCESSIVE MOISTURE OR DIRT; VIBRATION; EXCESSIVE AMBIENT TEMPERATURES. CONSULT AC TECHNOLOGY FOR MORE INFORMATION ON THE SUITABILITY OF A DRIVE TO A PARTICULAR ENVIRONMENT.

SCD models are suitable for UL pollution degree 2 environment only, and MUST be installed in an electrical enclosure which will provide complete mechanical protection and will maintain the internal temperature within the drive's ambient operating temperature rating. All drive models MUST be mounted in a vertical position for proper heatsink cooling.

Maintain a minimum spacing around the drive of at least 1 inch on each side and 2 inches on the top and bottom for units rated up to 5 HP (3.7 kW). For units rated 7.5 - 25 HP (5.5 - 18.5 kW), maintain at least 2 inches on each side and 4 inches on the top and bottom. Allow more spacing if the drive is mounted next to other heat-producing equipment. Do not mount drives above other drives or heat producing equipment. Fans or blowers should be used to insure proper cooling in tight quarters.

In order to properly size an enclosure, the heat generated by the drive(s) must be known. Refer to the HEAT LOSS columns in Section 5.0 - SCD RATINGS. The STD column is for standard units, and the THRU column is for through-hole mount units (drives with the through-hole mount option still generate some heat inside the enclosure that must be taken into account). An enclosure manufacturer can then determine the required enclosure size based on the total heat generated inside the enclosure (from the drive(s) and other heat sources), the maximum allowable temperature inside the enclosure, the maximum ambient temperature outside the enclosure, and the enclosure properties.

The SCD Series is UL approved for solid state motor overload protection. Therefore, a separate thermal overload relay is not required for single motor applications.

### 6.1 INSTALLATION AFTER A LONG PERIOD OF STORAGE

### WARNING!

Severe damage to the drive can result if it is operated after a long period of storage or inactivity without reforming the DC bus capacitors!

If input power has not been applied to the drive for a period of time exceeding three years (due to storage, etc), the electrolytic DC bus capacitors within the drive can change internally, resulting in excessive leakage current. This can result in premature failure of the capacitors if the drive is operated after such a long period of inactivity or storage.

In order to reform the capacitors and prepare the drive for operation after a long period of inactivity, apply input power to the drive for 8 hours prior to actually operating the motor.

## 6.2 EXPLOSION PROOF APPLICATIONS

Explosion proof motors that are not rated for inverter use lose their certification when used for variable speed. Due to the many areas of liability that may be encountered when dealing with these applications, the following statement of policy applies:

**“AC Technology Corporation inverter products are sold with no warranty of fitness for a particular purpose or warranty of suitability for use with explosion proof motors. AC Technology Corporation accepts no responsibility for any direct, incidental or consequential loss, cost, or damage that may arise through the use of its AC inverter products in these applications. The purchaser expressly agrees to assume all risk of any loss, cost, or damage that may arise from such application.”**

## 7.0 INPUT AC POWER REQUIREMENTS

### **WARNING!**

Hazard of electrical shock! Capacitors retain charge after power is removed. Disconnect incoming power and wait until the voltage between terminals B+ and B- is 0 VDC before servicing the drive.

The input voltage must match the nameplate voltage rating of the drive. Voltage fluctuation must not vary by greater than 10% overvoltage or 15% undervoltage.

**NOTE:** Drives with dual input voltage ratings must be programmed for the proper supply voltage (refer to Parameter 01 - LINE VOLTAGE SELECTION in Section 15.0 - DESCRIPTION OF PARAMETERS).

The drive is suitable for use on a circuit capable of delivering not more than 5,000 RMS symmetrical amperes at 5 HP (3.7 kW) and below, and 18,000 RMS symmetrical amperes at 7.5 - 25 HP (5.5 - 18.5 kW), at the drive's rated voltage.

If the kVA rating of the AC supply transformer is greater than 10 times the input kVA rating of the drive(s), an isolation transformer or 2-3% input line reactor must be added to the line side of the drive(s).

Three phase voltage imbalance must be less than 2.0% phase to phase. Excessive phase to phase imbalance can cause severe damage to the drive's power components.

Motor voltage should match line voltage in normal applications. The drive's maximum output voltage will equal the input voltage. Use extreme caution when using a motor with a voltage rating which is different from the input line voltage.

## 7.1 INPUT VOLTAGE RATINGS

**SD200 Series** drives are rated for 208/240 Vac, three phase, 50-60 Hz input. The drive will function with input voltages of 208 to 240 Vac (+10%, -15%), at 48 to 62 Hz.

**SD200Y Series** drives are rated for 208/240 Vac, single or three phase, 50-60 Hz input. The drive will function with input voltage of 208 to 240 Vac (+10%, -15%), at 48 to 62 Hz.

**SD400 Series** drives are rated for 400/480 Vac three phase, 50-60 Hz input. The drive will function with input voltages of 400 to 480 Vac (+10%, -15%), at 48 to 62 Hz.

**SD500 Series** drives are rated for 480/590 Vac, three phase, 50-60 Hz input, and will function with input voltages of 480 to 590 Vac (+10%, -15%), at 48 to 62 Hz.

**NOTE:** Parameter 01 - LINE VOLTAGE SELECTION must be programmed according to the applied input voltage. See Section 15.0 - DESCRIPTION OF PARAMETERS.

## 7.2 INPUT FUSING AND DISCONNECT REQUIREMENTS

A circuit breaker or a disconnect switch with fuses must be provided in accordance with the National Electric Code (NEC) and all local codes. Refer to the following tables for proper fuse/circuit breaker ratings and wire sizes.

INPUT FUSE & CIRCUIT BREAKER RATINGS							
208/240 Vac, 1 phase		208/240 Vac, 3 phase		400/480 Vac, 3 phase		480/590 Vac, 3 phase	
MODEL	RATING	MODEL	RATING	MODEL	RATING	MODEL	RATING
SD203Y	10 A	SD203Y	10 A				
SD205Y	10 A	SD205(Y)	10 A	SD405	10 A		
SD210Y	15 A	SD210(Y)	10 A	SD410	10 A	SD510	10 A
SD215Y	20 A	SD215(Y)	12 / 10 A	SD415	10 A		
SD220Y	25 / 20 A	SD220(Y)	15 / 12 A	SD420	10 A	SD520	10 A
SD230Y	30 / 25 A	SD230(Y)	20 / 15 A	SD430	10 A	SD530	10 A
SD250Y	45 / 40 A	SD250(Y)	30 / 25 A	SD450	15 A	SD550	12 A
		SD275	45 / 40 A	SD475	20 A	SD575	20 A
		SD2100	50 / 50 A	SD4100	30 / 25 A	SD5100	20 A
		SD2150	80 / 75 A	SD4150	40 / 40 A	SD5150	30 A
		SD2200	100 / 90 A	SD4200	50 / 45 A	SD5200	40 A
				SD4250	70 / 60 A	SD5250	45 A

**NOTE 1:** Use UL Class CC fast-acting, current limiting type fuses. Select fuses with low I<sup>2</sup> T values, rated at 200,000 AIC. Recommended fuses are Bussman KTK-R, JJK, and JJS. Similar fuses with equivalent ratings by other manufacturers may also be acceptable.

## WIRE SIZE REQUIREMENTS

208/240 Vac, 1 phase			208/240 Vac, 3 phase			400/480 Vac, 3 phase			480/590 Vac, 3 phase		
MODEL	AWG	mm <sup>2</sup>	MODEL	AWG	mm <sup>2</sup>	MODEL	AWG	mm <sup>2</sup>	MODEL	AWG	mm <sup>2</sup>
SD203Y	14	2.5	SD203Y	14	2.5						
SD205Y	14	2.5	SD205(Y)	14	2.5	SD405	14	2.5			
SD210Y	14	2.5	SD210(Y)	14	2.5	SD410	14	2.5	SD510	14	2.5
SD215Y	14	2.5	SD215(Y)	14	2.5	SD415	14	2.5			
SD220Y	14	2.5	SD220(Y)	14	2.5	SD420	14	2.5	SD520	14	2.5
SD230Y	12	4.0	SD230(Y)	14	2.5	SD430	14	2.5	SD530	14	2.5
SD250Y	10	6.0	SD250(Y)	12	4.0	SD450	14	2.5	SD550	14	2.5
			SD275	10	6.0	SD475	14	2.5	SD575	14	2.5
			SD2100	8	10	SD4100	12	4.0	SD5100	14	2.5
			SD2150	6	16	SD4150	10	6.0	SD5150	10	6.0
			SD2200	4	25	SD4200	8	10	SD5200	10	6.0
						SD4250	6	16	SD5250	8	10

## 8.0 POWER WIRING

### WARNING!

Hazard of electrical shock! Capacitors retain charge after power is removed. Disconnect incoming power and wait until the voltage between terminals B+ and B- is 0 VDC before servicing the drive.

Note drive input and output current ratings and check applicable electrical codes for required wire type and size, grounding requirements, over-current protection, and incoming power disconnect, before wiring the drive. Size conservatively to minimize voltage drop.

Strip off 0.20 to 0.25 inches (5 to 6 mm) of insulation for input power, output power, and DC Bus wiring.

The input power, output power, and DC Bus terminals must be tightened to a torque of 4.5 lb-in (0.5 Nm).

Input fusing and a power disconnect switch or contactor **MUST** be wired in series with terminals L1, L2, and L3 for three phase input models. For 208/240 Vac single phase input models, use terminals L1 and L2. This disconnect must be used to power down the drive when servicing, or when the drive is not to be operated for a long period of time, but should not be used to start and stop the motor.

**Repetitive cycling of a disconnect or input contactor (more than once every two minutes) may cause damage to the drive.**

### 8.1 WIRING FOR SINGLE PHASE OR THREE PHASE INPUT

If the drive is rated for single and three phase input (SD200Y models), wire to terminals L1 and L2 for single phase input, or wire to terminals L1, L2, and L3 for three phase input.

If the drive is rated for three phase input, wire the input to terminals L1, L2, and L3.

All three power output wires, from terminals T1, T2, and T3 to the motor, must be kept tightly bundled and run in a separate conduit away from all other power and control wiring.

It is not recommended to install contactors or disconnect switches between the drive and motor. Operating such devices while the drive is running can potentially cause damage to the drive's power components. If such a device is required, it should only be operated when the drive is in a STOP state. If there is potential for the device to be opened while the drive is running, the drive must be programmed for COAST to stop (see Parameter 4 - STOP METHOD), and an auxiliary contact on the device must be interlocked with the drive's run circuit. This will give the drive a stop command at the same time the device opens, and will not allow the drive to start again until the device is closed.

## 9.0 SCD POWER WIRING DIAGRAM

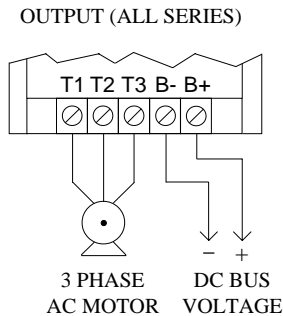
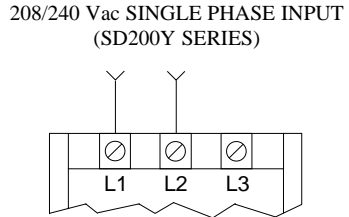
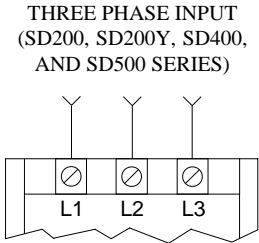

### WARNING!

Do not connect incoming AC power to output terminals T1, T2, or T3. Severe damage to the drive will result.

#### NOTES:

1. WIRE AND GROUND IN ACCORDANCE WITH NEC OR CEC, AND ALL APPLICABLE LOCAL CODES.
2. Motor wires MUST be run in a separate steel conduit away from control wiring and incoming AC power wiring.
3. Do not install contactors between the drive and the motor without consulting AC Technology for more information. Failure to do so may result in drive damage.
4. Use only UL and CSA listed and approved wire.
5. Minimum wire voltage ratings: 300 V for 208 and 240 Vac systems, and 600 V for 400, 480, and 590 Vac systems.
6. Wire gauge must be based on a minimum of 125% of the rated input/output current of the drive, and a minimum 75°C insulation rating. Use copper wire only.
7. Strip off 0.20 to 0.25 inches (5 to 6 mm) of insulation for input power, output power, and DC Bus wiring.

## 10.0 CONTROL WIRING

### 10.1 CONTROL WIRING VS. POWER WIRING

External control wiring **MUST** be run in a separate conduit away from all other input and output power wiring. If control wiring is not kept separate from power wiring, electrical noise may be generated on the control wiring that will cause erratic drive behavior. Use twisted wires or shielded cable grounded at the drive chassis **ONLY**. Recommended control wire is Belden 8760 (2-wire) or 8770 (3-wire), or equivalent.

Strip off 0.20 to 0.25 inches (5 to 6 mm) of insulation for control wiring, and torque the control terminals to 2 lb-in (0.2 Nm). Be careful not to overtorque the control terminals, as this will cause damage to the terminal strip. This is not covered under warranty and can only be repaired by replacing the control board.

### 10.2 TB-2 AND TB-4

The TB-2 terminal is the circuit common for the analog input and analog output functions. If necessary TB-2 may be connected to chassis ground.

The TB-4 terminal is the reference for all of the digital inputs (TB-1, 12, 13A, 13B, 13C). On standard SCD drives, TB-4 is at zero volt potential. Therefore, the digital inputs are active-low.

### 10.3 SURGE SUPPRESSION ON RELAYS

Current and voltage surges and spikes in the coils of contactors, relays, solenoids, etc, near or connected to the drive, can cause erratic drive operation. Therefore, a snubber circuit should be used on coils associated with the drive. For AC coils, snubbers should consist of a resistor and a capacitor in series across the coil. For DC coils, a free-wheeling or flyback diode should be placed across the coil. Snubbers are typically available from the manufacturer of the device.

### 10.4 START/STOP CONTROL

There are various control schemes that allow for 2-wire and 3-wire Start/Stop circuits. Refer to the wiring diagrams in Section 11.0 - SCD CONTROL WIRING DIAGRAMS

### 10.5 SPEED REFERENCE SIGNALS

The drive allows for three analog speed reference inputs:

**SPEED POT** Connect the wiper of a speed pot (rated 2.5k $\Omega$  up to 10k $\Omega$ ) to terminal TB-5/25, and connect the high and low end leads to terminals TB-11 and TB-2, respectively.

**0-10 VDC** Wire the positive to terminal TB-5/25 and the negative to terminal TB-2. TB-5/25 input impedance is 120 kilohms when programmed for 0-10 VDC input.

**4-20 mA** Wire the positive to terminal TB-5/25 and the negative to terminal TB-2. TB-5/25 input impedance is 100 ohms when programmed for 4-20 mA.

**NOTE:** When the drive is powered down, the input impedance of terminal TB-5/25 becomes 57 kilohms. If TB-5/25 was programmed as a 4-20 mA input, the 4-20 mA source will suddenly encounter a high input impedance.

## 10.6 SPEED REFERENCE SELECTION

If only one speed reference is required, set Parameter 05 - STANDARD SPEED SOURCE to the desired speed reference. The selections are: KEYPAD (the ▲ and ▼ buttons on the front of the drive), PRESET SPEED #1 (Parameter 31), a 0-10 VDC signal, or a 4-20 mA signal.

If multiple speed references are required, terminals 13A, 13B, and 13C can be programmed to select other speed references in addition to the STANDARD SPEED SOURCE (Parameter 05). When the TB-13 terminal is closed to TB-4, the drive will follow the selected speed reference. If a speed reference is not selected using TB-13A, 13B, or 13C, speed control will default back to the source programmed in STANDARD SPEED SOURCE.

When using the DeviceNet interface, speed reference selection can be done as described above. However, DeviceNet can override the selected speed reference and directly control the drive speed. Refer to Appendix B - DEVICENET CONTROL for more information.

### 0 - 10 VDC and 4 - 20 mA INPUT SIGNALS

TB-13A, TB-13B, and TB-13C can all be programmed to select a 0-10 VDC or 4-20 mA analog speed reference input.

### PRESET SPEEDS

TB-13A can be programmed to select PRESET SPEED #1, TB-13B to select PRESET SPEED #2, and TB-13C to select PRESET SPEED #3. There are a total of seven preset speeds, which are activated by different combinations of contact closures between TB-13A, 13B, 13C and TB-4. Refer to Parameters 31-37 in Section 15.0 - DESCRIPTION OF PARAMETERS.

### JOG

TB-13B can be programmed to select either JOG FORWARD or JOG REVERSE. The Jog speed is set by PRESET SPEED #2. Close TB-13B to TB-4 to JOG, and open the contact to STOP.

#### **WARNING!**

When operating in JOG mode, the STOP terminal (TB-1) and the STOP key (on the optional remote keypad) **WILL NOT** stop the drive. To stop the drive, remove the JOG command.

JOG REVERSE will operate the drive in reverse rotation even if ROTATION DIRECTION (Parameter 17) is set to FORWARD ONLY.

**NOTE:** If the drive is commanded to JOG while running, the drive will enter JOG mode and run at PRESET SPEED #2. When the JOG command is removed, the drive will STOP.

## MOTOR OPERATED POT (MOP) / FLOATING POINT CONTROL

TB-13B and TB-13C are used for this function, which controls the drive speed using contacts wired to the terminal strip. Program TB-13B for DECREASE FREQ (05), and program TB-13C for INCREASE FREQ (05). Closing TB-13B to TB-4 will cause the speed setpoint to decrease until the contact is opened. Closing TB-13C to TB-4 will cause the speed setpoint to increase until the contact is opened. The INCREASE FREQ function will only operate while the drive is running.

**NOTE:** If TB-13A, TB-13B, and TB-13C are all programmed to select speed references, and two or three of the terminals are closed to TB-4, the higher terminal has priority and will override the others. For example, if TB-13A is programmed to select 0-10VDC, and TB-13C is programmed to select PRESET SPEED #3, closing both terminals to TB-4 will cause the drive to respond to PRESET SPEED #3, because TB-13C overrides TB-13A.

The exception to this is the MOP function, which requires the use of TB-13B and TB-13C. This leaves TB-13A to be used for some other function. If TB-13A is programmed for a speed reference, and TB-13A is closed to TB-4, TB-13A will override the MOP function.

### 10.7 ANALOG OUTPUT SIGNALS

Terminal TB-30 can provide a 0-10 VDC or a 2-10 VDC signal proportional to output frequency or load, and TB-31 can provide the same signals proportional to load only. The 2-10 VDC signal can be converted to a 4-20 mA signal using a resistor in series with the signal such that the total load resistance is 500 Ohms. Refer to Parameters 08 and 09 in Section 15.0 - DESCRIPTION OF PARAMETERS.

**NOTE:** These analog output signals cannot be used with “loop-powered” devices that derive power from a 4-20 mA signal.

### 10.8 DRIVE STATUS DIGITAL OUTPUTS

There are two open-collector outputs at terminals TB-14 and TB-15. The open-collector circuits are current-sinking types rated at 30 VDC and 50 mA maximum.

The open-collector outputs can be programmed to indicate one of various drive status conditions. Refer to Parameters 06 and 13 in Section 15.0 - DESCRIPTION OF PARAMETERS.

The diagram below illustrates how the 12 VDC power supply at TB-11 can be used with the open-collector output to drive an external relay:

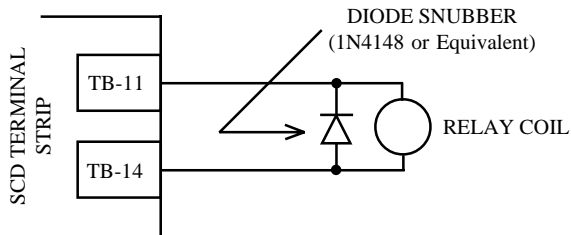

## 11.0 SCD CONTROL WIRING DIAGRAMS

### 11.1 SCD TERMINAL STRIP

Shown below is the terminal strip on the main control board, along with a brief description of the function of each terminal.

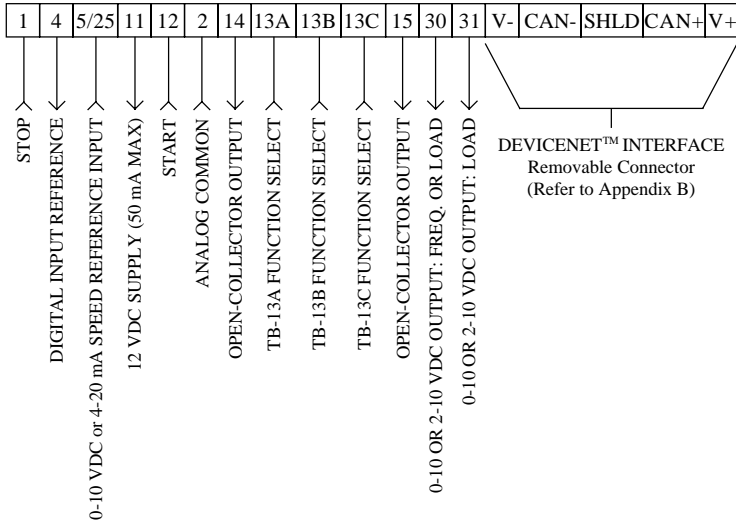

**NOTE:** The function of terminals TB-13A, TB-13B, TB-13C, TB-14, TB-15, TB-30, and TB-31 are dependent on the programming of certain parameters. Refer to Sections 14.0 - PARAMETER MENU and 15.0 - DESCRIPTION OF PARAMETERS.

Additional information on operating the drive from the terminal strip can be found in Section 10.0 - CONTROL WIRING. The following diagrams provide a quick reference to wire the drive for the most common configurations.

## 11.2 TWO-WIRE START/STOP CONTROL

Shown below is the wiring diagram for a typical two-wire start/stop control scheme, using one maintained contact (such as that from a PLC) for RUN and STOP commands.

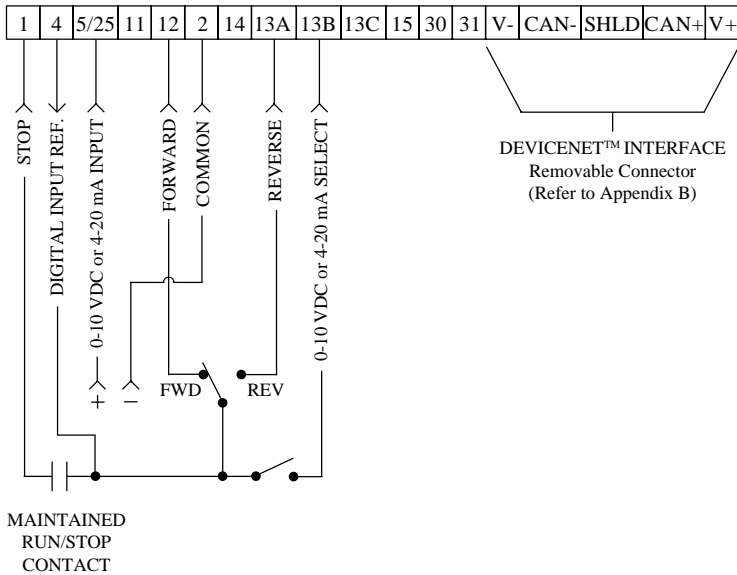

### NOTES:

1. Close TB-1 to TB-4 to RUN, and open TB-1 to TB-4 to STOP.
2. If reverse direction is also required, ROTATION DIRECTION (Parameter 17) must be set to FORWARD AND REVERSE (02), and TB-13A (Parameter 10) must be set to START REVERSE (06). If reverse direction is not required, TB-12 must be wired directly to TB-4.
3. For 0-10 VDC or 4-20 mA speed control, use one of the following methods:
  1. Program one of the TB-13 terminals (13A, 13B, or 13C) for 0-10 VDC (02) or 4-20 mA (03). When that TB-13 terminal is closed to TB-4, the drive will respond to the selected speed reference signal. If that TB-13 terminal is not closed to TB-4, the drive will respond to the speed control source selected in Parameter 05 - STANDARD SPEED SOURCE. This method must be used if it is necessary to toggle between two speed sources.
  2. Program Parameter 05 - STANDARD SPEED SOURCE for 0-10 VDC (03) or 4-20 mA (04). This method is preferable if only one speed source is required, as this method leaves the TB-13 terminals free to be used for other functions.

### 11.3 ALTERNATE TWO-WIRE START/STOP CONTROL

Shown below is the wiring diagram for an alternate two-wire start/stop control scheme, using one maintained contact for RUN FORWARD and another maintained contact for RUN REVERSE.

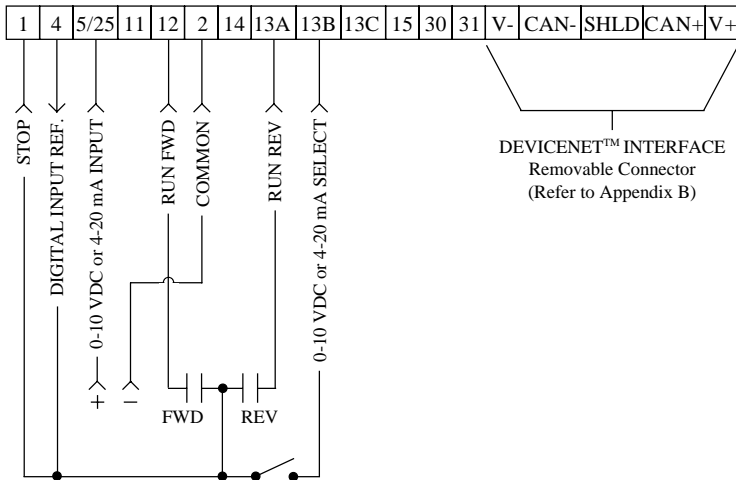

#### NOTES:

1. For this control scheme, TB-13A MUST be set to RUN REVERSE (05), even if REVERSE direction is not required. Refer to Parameter 10 - TB13A FUNCTION.
2. Close TB-12 to TB-4 to RUN in forward direction, and open TB-12 to TB-4 to STOP.
3. If reverse direction is also required, ROTATION DIRECTION (Parameter 17) must be set to FORWARD AND REVERSE (02). Close TB-13A to TB-4 to RUN in REVERSE, and open TB-13A to TB-4 to STOP. If TB-12 and TB-13A are both closed to TB-4, the drive will STOP.
4. For 0-10 VDC or 4-20 mA speed control, use one of the following methods:
  1. Program one of the TB-13 terminals (13A, 13B, or 13C) for 0-10 VDC (02) or 4-20 mA (03). When that TB-13 terminal is closed to TB-4, the drive will respond to the selected speed reference signal. If that TB-13 terminal is not closed to TB-4, the drive will respond to the speed control source selected in Parameter 05 - STANDARD SPEED SOURCE. This method must be used if it is necessary to toggle between two speed reference sources.
  2. Program Parameter 05 - STANDARD SPEED SOURCE for 0-10 VDC (03) or 4-20 mA (04). This method is preferable if only one speed reference source is required, as this method leaves the TB-13 terminals free to be used for other functions.

## 11.4 THREE-WIRE START/STOP CONTROL

Shown below is the wiring diagram for a typical three-wire start/stop control scheme, using momentary contacts (such as pushbuttons) for START and STOP commands.

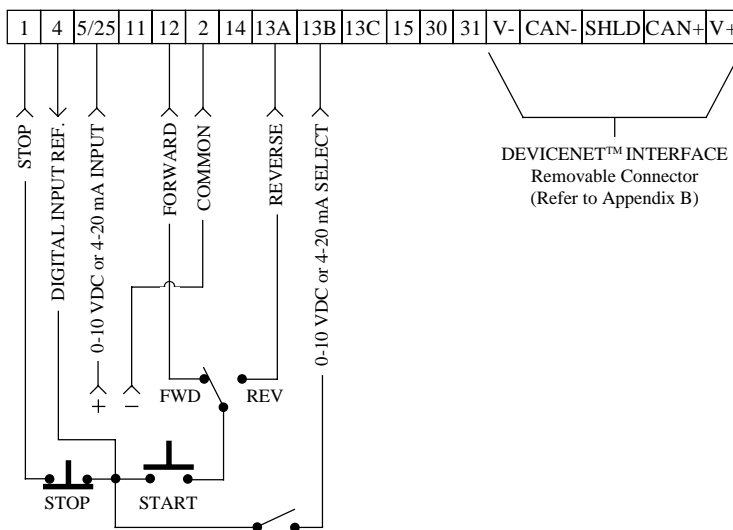

### NOTES:

1. Momentarily close TB-12 to TB-4 to START the drive in forward direction, and momentarily open TB-1 to TB-4 to STOP the drive.
2. If reverse direction is also required, ROTATION DIRECTION (Parameter 17) must be set to FORWARD AND REVERSE (02), and TB-13A (Parameter 10) must be set to START REVERSE (06). If the FWD/REV switch is changed while the drive is running, the drive will not change direction until the START button is pushed. If reverse direction is not required, the other side of the START pushbutton must be wired directly to TB-12.
3. For 0-10 VDC or 4-20 mA speed control, use one of the following methods:
  1. Program one of the TB-13 terminals (13A, 13B, or 13C) for 0-10 VDC (02) or 4-20 mA (03). When that TB-13 terminal is closed to TB-4, the drive will respond to the selected speed reference signal. If that TB-13 terminal is not closed to TB-4, the drive will respond to the speed control source selected in Parameter 05 - STANDARD SPEED SOURCE. This method must be used if it is necessary to toggle between two speed sources.
  2. Program Parameter 05 - STANDARD SPEED SOURCE for 0-10 VDC (03) or 4-20 mA (04). This method is preferable if only one speed source is required, as this method leaves the TB-13 terminals free to be used for other functions.

## 11.5 SPEED POT AND PRESET SPEED CONTROL

Shown below is the wiring for SPEED POT and/or PRESET SPEED control, and either a two-wire or three-wire start/stop circuit:

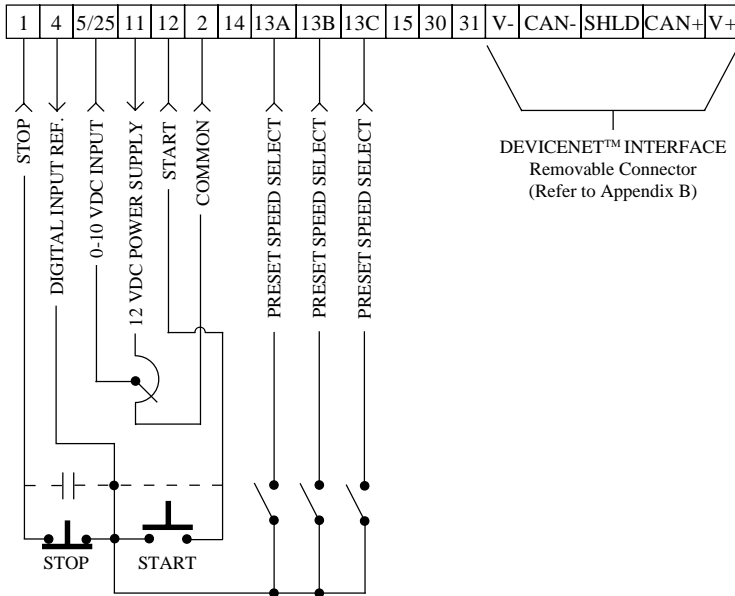

### NOTES:

1. Program the PRESET SPEEDS (Parameters 31-37) to the desired values.
2. Program TB-13A (Parameter 10) to PRESET SPEED #1 (04), TB-13B (Parameter 11) to PRESET SPEED #2 (04), and TB-13C (Parameter 12) to PRESET SPEED #3 (04). To select a preset speed, close the appropriate TB-13 terminal(s) to TB-2 (refer to Parameters 31-37 for the Preset Speed Activation table).
3. If reverse rotation is also required, TB-13A cannot be used as a PRESET SPEED SELECT. TB-13A must be programmed to select RUN REVERSE (05) or START REVERSE (06), leaving only TB-13B and TB-13C to select preset speeds.
4. For speed pot control, program Parameter 05 - STANDARD SPEED SOURCE for 0-10 VDC (03). If none of the preset speeds are selected (all of the TB-13 terminals are open), the drive will respond to the speed pot.

## 12.0 INITIAL POWER UP AND MOTOR ROTATION

### WARNING!

DO NOT connect incoming AC power to output terminals T1, T2, and T3! Severe damage to the drive will result. Do not continuously cycle input power to the drive more than once every two minutes. Damage to the drive will result.

### WARNING!

Hazard of electrical shock! Wait three minutes after disconnecting incoming power before servicing drive. Capacitors retain charge after power is removed.

### WARNING!

Severe damage to the drive can result if it is operated after a long period of storage or inactivity without reforming the DC bus capacitors!

If input power has not been applied to the drive for a period of time exceeding three years (due to storage, etc), the electrolytic DC bus capacitors within the drive can change internally, resulting in excessive leakage current. This can result in premature failure of the capacitors if the drive is operated after such a long period of inactivity or storage.

In order to reform the capacitors and prepare the drive for operation after a long period of inactivity, apply input power to the drive for 8 hours prior to actually operating the motor.

Before attempting to operate the drive, motor, and driven equipment, be sure all procedures pertaining to installation and wiring have been properly followed.

Disconnect the driven load from the motor. Verify that the drive input terminals (L1, L2, and L3) are wired to the proper input voltage per the nameplate rating of the drive.

Energize the incoming power line. The LED display will flash a three digit number (322 in the example below) that identifies the parameter version contained in the drive. The display should then read "--", which indicates that the drive is in a STOP condition. This is shown below:

Apply input power

Display flashes parameter version (300-399)

Display then reads "--"

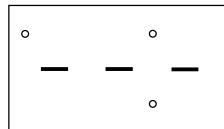
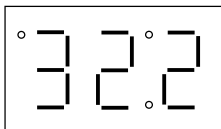

Follow the procedure below to check the motor rotation. This procedure assumes that the drive has been powered up for the first time, and that none of the parameters have been changed.

1. Use the ▼ button to decrease the speed setpoint to 00.0 Hz. The left decimal point will illuminate as the speed setpoint is decreased. If the ▼ button is held down, the speed setpoint will decrease by tenths of Hz until the next whole Hz is reached, and then it will decrease by one Hz increments. Otherwise, each push of the ▼ button will decrease the speed setpoint by a tenth of a Hz.

Once 00.0 Hz is reached, the display will toggle between “00.0” and “- - -”, which indicates that the drive is in a STOP condition with a speed setpoint of 00.0 Hz.

2. Give the drive a START command. This can be done using one of several wiring methods described in Section 11.0 - SCD CONTROL WIRING DIAGRAMS. Once the START command is issued, the display will read “00.0”, indicating that the drive is in a RUN condition with a speed setpoint of 00.0 Hz.
3. Use the ▲ button to increase the speed setpoint until the motor starts to rotate. The left decimal point will light as the speed setpoint is increased. If the ▲ button is held down, the speed setpoint will increase by tenths of Hz until the next whole Hz is reached, and then it will increase by one Hz increments. Otherwise, each push of the button will increase the speed setpoint by a tenth of a Hz.
4. If the motor is rotating in the wrong direction, give the drive a STOP command and remove power from the drive. Wait three minutes for the bus capacitors to discharge, and swap any two of the motor wires connected to T1, T2, and T3.

**NOTE:** The drive is phase insensitive with respect to incoming line voltage. This means that the drive will operate with any phase sequence of the incoming three phase voltage. Therefore, to change the motor rotation, the phases must be swapped at the drive output terminals or at the motor.

### 13.0 PROGRAMMING THE SCD DRIVE

The drive may be programmed by one of three methods: using the three buttons and 3-digit LED display on the front of the drive, programming the Electronic Programming Module (EPM) using the optional EPM Programmer, and through the DeviceNet interface (refer to Appendix B). This section describes programming the drive using the buttons and display, which are shown below:



To enter the PROGRAM mode to access the parameters, press the **Mode** button. This will activate the PASSWORD prompt (if the password has not been disabled). The display will read "00" and the upper right-hand decimal point will be blinking, as shown below:

Press **Mode**

Display reads "00"

Upper right decimal point blinks

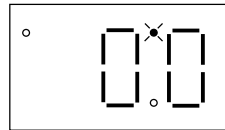

Use the **▲** and **▼** buttons to scroll to the password value (the factory default password is "225") and press the **Mode** button. Once the correct password value is entered, the display will read "P01", which indicates that the PROGRAM mode has been accessed at the beginning of the parameter menu (P01 is the first parameter). This is shown below:

Use **▲** and **▼** to scroll to the password value

Press **Mode** to enter password

Parameter menu is accessed at the first parameter

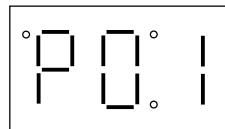
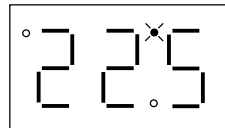

**NOTE:** If the display flashes “Er”, the password was incorrect, and the process to enter the password must be repeated.

Use the ▲ and ▼ buttons to scroll to the desired parameter number. In the example below, Parameter 19 is being displayed, which is the ACCELERATION TIME of the drive:

Use ▲ and ▼ to scroll to the desired parameter number (the example is Parameter 19 - ACCELERATION TIME)

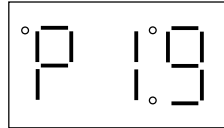

Once the desired parameter number is found, press the **Mode** button to display the present parameter setting. The upper right-hand decimal point will begin blinking, indicating that the present parameter setting is being displayed, and that it can be changed by using the ▲ and ▼ buttons.

Press **Mode** to display present parameter setting (example setting is 20.0)

Upper right decimal point blinks

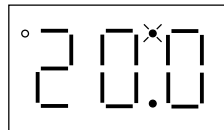

Use ▲ and ▼ to change setting (example setting changed to 30.0)

Press **Mode** to store new setting

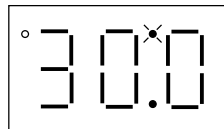

Pressing the **Mode** will store the new setting and also exit the PROGRAM mode. To change another parameter, press the **Mode** key again to re-enter the PROGRAM mode (the parameter menu will be accessed at the parameter that was last viewed or changed before exiting). If the **Mode** key is pressed within two minutes of exiting the PROGRAM mode, the password is not required access the parameters. After two minutes, the password must be entered in order to access the parameters again.

### 13.1 SETTING VALUES IN TENTHS OF UNITS ABOVE 100

Parameter settings and the keypad speed command can always be adjusted in tenths of unit increments from 0.0 to 99.9. Above 100 however, values can be set in whole units or tenths of units, depending on the setting of Parameter 16 - UNITS EDITING.

If Parameter 16 - UNITS EDITING is set to WHOLE UNITS (02), parameter values and the keypad speed command can only be adjusted by whole unit increments above 100. For example, Parameter 19 - ACCELERATION TIME could not be set to 243.7 seconds. It could only be set to 243 or 244 seconds. Likewise, the keypad speed command (set using the ▲ and ▼ buttons) could not be set to 113.4 Hz. It could only be set to 113 or 114 Hz.

If, however, Parameter 16 - UNITS EDITING is set to TENTHS OF UNITS (01), parameter values and the keypad speed command can be adjusted in tenths of unit increments up to a value of 1000 (above 1000, whole unit increments only). Each push of the ▲ or ▼ button will adjust the value by one tenth of a unit. If the ▲ or ▼ button is pressed and held, the value will increment by tenths of units until the next whole unit is reached, and then the value will increment by whole units.

When a value above 100 is being adjusted by tenths of units, the value is shifted to the left by one digit so that the tenths portion of the value can be displayed. This results in the first digit (reading from left to right) of the value disappearing from the display. Also, the lower decimal point will blink to indicate that the actual value is above 100. Once the value is no longer being adjusted, the value will shift back to the right and the tenths portion of the value will disappear.

In the example below, Parameter 19 - ACCELERATION TIME is presently set to 243.0 seconds, and is being increased to 243.7 seconds.

Go to Parameter 19 and press **Mode**  
to see present setting ("243" seconds)

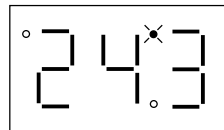

Upper right decimal point blinks

Press ▲ button to see tenths portion  
Value shifts to the left ("2" disappears)

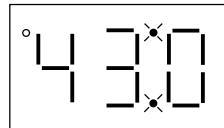

Upper right decimal point and lower  
decimal point blink

Press ▲ button to scroll up to "43.7"

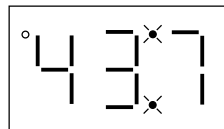

Press **Mode** to store new value

Every SC Series drive has an Electronic Programming Module (EPM) installed on the main control board. The EPM stores the user's parameter settings and special OEM default settings (if programmed). The EPM is removable, allowing it to be installed in another drive for quick set-up. For example, if a drive is being replaced with a new one, the EPM can be taken out of the first drive and installed in the new drive. Downtime is minimized because the new drive does not require programming - it is ready to run when the EPM is installed.

The SC Series drive contains two or three sets of parameter values, depending on whether the drive has been programmed with optional OEM default settings. The first set of values is the factory default settings, which are permanently stored on the main control board and cannot be changed. The second set of values is the user settings, which are stored in the EPM. When the drive leaves the factory, the user settings are the same as the factory default settings, but the user settings can be changed to configure the drive for a particular application. The optional third set of values is the OEM default settings, which are also stored in the EPM. OEM default settings are typically used in cases where many drives are used for the same application, which requires that all of the drives have the same parameter settings. The OEM default settings cannot be changed without the optional EPM Programmer. The drive can be programmed to operate according to the user settings or the OEM default settings (see Parameter 48 in Section 15.0).

**NOTE:** The drive will not operate without the EPM installed. The drive will display "F1" if the EPM is missing or damaged.

**WARNING!**

Do not remove the EPM while power is applied to the drive. Damage to the EPM and/or drive may result.

An EPM Programmer is available as an option from AC Tech, which has the ability to quickly and easily program many SC Series drives for the same configuration. Once a "master" EPM is programmed with the desired parameter settings, the EPM Programmer can copy those settings to other EPMs, allowing many drives to be configured very quickly. Please consult the EPM Programmer Instruction Manual or contact the factory for more information.

If the OEM settings in the EPM become corrupted, the drive will operate normally, until an attempt is made to perform a RESET OEM using Parameter 48 - PROGRAM SELECTION. The drive will then flash "GF" to indicate that the OEM settings are no longer valid. This will require that the EPM be re-programmed using the optional EPM Programmer.

If the OEM settings and the user settings are both corrupted, the drive will display "GF" immediately and the drive will require a RESET 60 or RESET 50 using Parameter 48 - PROGRAM SELECTION. Once the RESET is performed, the parameters can then be programmed individually to match the OEM default settings. This will allow the drive to operate as if it were in OEM mode, even though it is actually operating in USER mode. Refer to Parameter 48 in Section 15.0 - DESCRIPTION OF PARAMETERS.

**NOTE:** The drive will also display "GF" if a RESET OEM or OPERATE WITH OEM SETTINGS is attempted when the drive is not equipped with the OEM default option.

## 14.0 PARAMETER MENU

NO.	PARAMETER NAME	RANGE OF ADJUSTMENT	FACTORY DEFAULT (NOTE 1)
01	LINE VOLTAGE	HIGH (01), LOW (02)	HIGH (01)
02	CARRIER FREQUENCY	4kHz (01), 6 kHz (02), 8 kHz (03), 10 kHz (04)	6 kHz (02)
03	START METHOD	NORMAL (01), START ON POWER UP (02), START WITH DC BRAKE (03), AUTO RESTART WITH DC BRAKE (04), FLYING RESTART 1 (05), FLYING RESTART 2 (06), FLYING RESTART 3 (07)	NORMAL (01)
04	STOP METHOD	COAST (01), COAST WITH DC BRAKE (02), RAMP (03), RAMP WITH DC BRAKE (04)	COAST (01)
05	STANDARD SPEED SOURCE	KEYPAD (01), PRESET #1 (02), 0-10 VDC (03), 4-20 mA (04)	KEYPAD (01)
06 13	TB-14 OUTPUT TB-15 OUTPUT	NONE (01), RUN (02), FAULT (03), INVERSE FAULT (04), FAULT LOCKOUT (05), AT SET SPEED (06), ABOVE PRESET #3 (07), CURRENT LIMIT (08), AUTO SPEED (09), REVERSE (10)	NONE (01) NONE (01)
08	TB-30 OUTPUT	NONE (01), 0-10 VDC FREQ (02), 2-10 VDC FREQ (03), 0-10 VDC LOAD (04), 2-10 VDC LOAD (05)	NONE (01)
09	TB-31 OUTPUT	NONE (01), 0-10 VDC LOAD (02), 2-10 VDC LOAD (03), DYNAMIC BRAKING (04)	NONE (01)
10	TB-13A FUNCTION SELECT	NONE (01), 0-10 VDC (02), 4-20 mA (03), PRESET SPEED #1 (04), RUN REVERSE (05), START REVERSE (06), EXTERNAL FAULT (07), Factory Reserved (08), DB FAULT (09), AUXILIARY STOP (10), ACCEL/DECCEL #2 (11)	NONE (01)
11	TB-13B FUNCTION SELECT	NONE (01), 0-10 VDC (02), 4-20 mA (03), PRESET SPEED #2 (04), DECREASE FREQ (05), JOG FORWARD (06), JOG REVERSE (07), AUXILIARY STOP (08)	NONE (01)

NOTE 1: Factory defaults are shown for a 60 Hz base frequency. See Parameter 48 for 50 Hz base frequency.

**PARAMETER MENU (CONT'D)**

<b>NO.</b>	<b>PARAMETER NAME</b>	<b>RANGE OF ADJUSTMENT</b>	<b>FACTORY DEFAULT (NOTE 1)</b>
12	TB-13C FUNCTION SELECT	NONE (01), 0-10 VDC (02), 4-20 mA (03), PRESET SPEED #3 (04), INCREASE FREQ (05), EXTERNAL FAULT (06), Factory Reserved (07), DB FAULT (08), ACCEL/DECEL #2 (09)	NONE (01)
13	TB-15 OUTPUT	(SEE PARAMETER 6 - TB-14 OUTPUT)	NONE (01)
14	CONTROL	TERMINAL STRIP & DEVICENET (01), DEVICENET ONLY (02),	TERMINAL STRIP & DEVICENET (01)
16	UNITS EDITING	TENTHS OF UNITS (01), WHOLE UNITS (02)	WHOLE UNITS (02)
17	ROTATION	FORWARD ONLY (01), FORWARD AND REVERSE (02)	FORWARD ONLY (01)
19	ACCELERATION TIME	0.1 - 3600.0 SEC	20.0 SEC
20	DECELERATION TIME	0.1 - 3600.0 SEC	20.0 SEC
21	DC BRAKE TIME	0.0 - 3600.0 SEC	0.0 SEC
22	DC BRAKE VOLTAGE	0.0 - 30.0 %	0.0 %
23	MINIMUM FREQUENCY	0.0 - MAXIMUM FREQUENCY	0.0 Hz
24	MAXIMUM FREQUENCY	MINIMUM FREQ - 240.0 Hz (NOTE 2)	60.0 Hz
25	CURRENT LIMIT	30 - 180 % (NOTE 3)	180%
26	MOTOR OVERLOAD	30 - 100 %	100%
27	BASE FREQUENCY	25.0 - 500.0 Hz (NOTE 4)	60.0 Hz
28	FIXED BOOST	0.0 - 30.0 %	1.00%
29	ACCEL BOOST	0.0 - 20.0 %	0.00%
30	SLIP COMPENSATION	0.0 - 5.0 %	0.00%
31-37	PRESET SPEEDS	0.0 - MAXIMUM FREQUENCY	0.0 Hz
38	SKIP BANDWIDTH	0.0 - 10.0 Hz	0.0 Hz
39	SPEED SCALING	0.0 - 6500.0	0

NOTE 1: Factory defaults are shown for a 60 Hz base frequency. See Parameter 48 for 50 Hz base frequency.

NOTE 2: Maximum setting is 999.9 Hz on drives with High Output Frequency option. Consult the factory.

NOTE 3: If LINE VOLTAGE is set to LOW, maximum setting is 150%.

NOTE 4: Maximum setting is 1300.0 Hz (factory default is 999.9) on drives with High Output Frequency option. Consult the factory.

**PARAMETER MENU (CONT'D)**

<b>NO.</b>	<b>PARAMETER NAME</b>	<b>RANGE OF ADJUSTMENT</b>	<b>FACTORY DEFAULT (NOTE 1)</b>
40	FREQUENCY SCALING	3.0 - 2000.0 Hz	60.0 Hz
41	LOAD SCALING	10 - 200 %	200 %
42	ACCEL / DECEL #2	0.1 - 3600.0 SEC	20.0 SEC
44	PASSWORD	000 - 999	225
47	CLEAR HISTORY	MAINTAIN (01), CLEAR (02)	MAINTAIN (01)
48	PROGRAM SELECTION	USER SETTINGS (01), OEM SETTINGS (02), RESET OEM (03), RESET 60 (04), RESET 50 (05), TRANSLATE (06)	USER SETTINGS (01)
50	FAULT HISTORY	(VIEW-ONLY)	(N/A)
51	SOFTWARE CODE	(VIEW-ONLY)	(N/A)
52	DC BUS VOLTAGE	(VIEW-ONLY)	(N/A)
53	MOTOR VOLTAGE	(VIEW-ONLY)	(N/A)
54	LOAD	(VIEW-ONLY)	(N/A)
55	0-10 VDC INPUT	(VIEW-ONLY)	(N/A)
56	4-20 mA INPUT	(VIEW-ONLY)	(N/A)
57	TB STRIP STATUS	(VIEW-ONLY)	(N/A)
58	KEYPAD STATUS	(VIEW-ONLY)	(N/A)
59	TB-30 OUTPUT	(VIEW-ONLY)	(N/A)
60	TB-31 OUTPUT	(VIEW-ONLY)	(N/A)
85	MOTOR RATED RPM	1 - 65000 RPM	1800 RPM
86	MOTOR RATED AMPS	0.0 - 999.9 AMPS	100.0 AMPS
87	MOTOR RATED VOLTS	0 - 1000 VOLTS	100 VOLTS
88	MOTOR RATED FREQ	0 - 1000 Hz	60 Hz
89	DRIVE RATED AMPS	0.0 - 999.9 AMPS	100.0 AMPS
90	DRIVE RATED VOLTS	0 - 1000 VOLTS	100 VOLTS

NOTE 1: Factory defaults are shown for a 60 Hz base frequency. See Parameter 48 for 50 Hz base frequency.

**PARAMETER MENU (CONT'D)**

<b>NO.</b>	<b>PARAMETER NAME</b>	<b>RANGE OF ADJUSTMENT</b>	<b>FACTORY DEFAULT (NOTE 1)</b>
C00	DNET NODE ADDRESS	0 - 63	63
C01	DNET BAUD RATE	125 kbps (0), 250 kbps (1), 500 kbps (2)	125 kbps (0)
C02	DNET LOSS ACTION	FAULT & STOP (0), IGNORE (1), AC TECH (2)	FAULT & STOP (0)
C03	DNET OUTPUT ASSY	1 BASIC CONTACTOR (1), 2 BASIC OVERLOAD (2), 3 BASIC MOTOR STARTER (3), 4 EXTENDED CONTACTOR (4), 5 EXTENDED MOTOR STARTER (5), 20 BASIC SPEED CONTROL (6), 21 EXTENDED SPEED CONTROL (7), 100 EXTENDED SPEED CONTROL Hz (8)	20 BASIC SPEED CONTROL (6)
C04	DNET INPUT ASSY	50 BASIC OVERLOAD (1), 51 EXTENDED OVERLOAD (2) 52 BASIC MOTOR CONTROL (3), 53 EXTENDED MOTOR CONTROL 1 (4), 54 EXTENDED MOTOR CONTROL 2 (5), 70 BASIC SPEED CONTROL (6), 71 EXTENDED SPEED CONTROL (7), 101 EXTENDED SPEED CONTROL Hz (8), 102 CUSTOM ASSEMBLY (9)	70 BASIC SPEED CONTROL (6)
C05	DNET CUSTOM ASSY 0	0 - 150	0
C06	DNET CUSTOM ASSY 1	0 - 150	0
C07	DNET CUSTOM ASSY 2	0 - 150	0
C08	DNET CUSTOM ASSY 3	0 - 150	0
C09	DNET MOTOR TYPE	NON-STANDARD MOTOR (0), PM DC MOTOR (1), FC DC MOTOR (2), PM SYNCH. MOTOR (3), FC SYNCH. MOTOR (4), SWITCHED RELUCT. (5), WOUND ROTOR INDUCTION (6), SQUIRREL CAGE INDUCTION (7), STEPPER MOTOR (8), SINUSOIDAL PM BL (9), TRAPEZOIDAL PM BL (10)	SQUIRREL CAGE INDUCTION (7)
C10	DNET DIAGNOSTICS	(READ ONLY)	(N/A)

## 15.0 DESCRIPTION OF PARAMETERS

### P01 LINE VOLTAGE SELECTION

This calibrates the drive for the actual applied input voltage, and can be set to HIGH (01) or LOW (02). Refer to the table below for the proper setting depending on the input voltage.

MODEL	RATED INPUT VOLTAGE	INPUT PHASE	APPLIED INPUT VOLTAGE	PARAMETER SETTING
SF200Y	208 / 240 Vac	1 or 3	220 - 240 Vac	HIGH (01)
		1 or 3	200 - 208 Vac	LOW (02)
SF200	208 / 240 Vac	3	220 - 240 Vac	HIGH (01)
		3	200 - 208 Vac	LOW (02)
SF400	400 / 480 Vac	3	440 - 480 Vac	HIGH (01)
		3	380 - 415 Vac	LOW (02)
SF500	480 / 590 Vac	3	575 - 600 Vac	HIGH (01)
		3	460 - 480 Vac	LOW (02)

**NOTE:** If this parameter is changed while the drive is running, the new value will not take effect until the drive is stopped.

### P02 CARRIER FREQUENCY

This sets the switching rate of the output IGBT's. Increasing the carrier frequency will result in less audible motor noise. Available settings are: 4 kHz, 6 kHz, 8 kHz, and 10 kHz.

PARAMETER SETTING	CARRIER FREQUENCY	MAXIMUM OUTPUT FREQUENCY (NOTE 1)	AMBIENT OR OUTPUT DERATE (NOTE 2)
01	4 kHz	240.0 Hz (400.0 Hz)	50 C or 100%
02	6 kHz	240.0 Hz (600.0 Hz)	50 C or 100%
03	8 kHz	240.0 Hz (999.9 Hz)	43 C or 92%
04	10 kHz	240.0 Hz (999.9 Hz)	35 C or 82%

**NOTE 1:** For drives with the High Output Frequency option, the carrier frequency also determines the maximum output frequency (shown in parenthesis).

**NOTE 2:** The SCD drive is fully rated up to 6 kHz carrier frequency. If the 8 kHz or 10 kHz carrier frequency is selected, the drive's ambient temperature rating OR output current rating must be derated to the value shown in the table above.

**NOTE 3:** If this parameter is changed while the drive is running, the change will not take effect until the drive is stopped. Therefore, the allowable maximum frequency for drives with the High Output Frequency option (see NOTE 1) will not change if the carrier frequency is changed while the drive is running.

### **P03      START METHOD**

#### **WARNING!**

Automatic starting of equipment may cause damage to equipment and/or injury to personnel! Automatic start should only be used on equipment that is inaccessible to personnel.

- 01 **NORMAL:** The drive will start when the appropriate contact is closed on the terminal strip, or by pressing the START key on the optional remote keypad. See Parameter 14.
- 02 **START ON POWER UP:** The drive will automatically start upon application of input power.
- 03 **START WITH DC BRAKE:** When a START command is given, the drive will apply DC BRAKE VOLTAGE (Parameter 22) for the duration of DC BRAKE TIME (Parameter 21) prior to starting the motor to ensure that the motor is not turning.
- 04 **AUTO RESTART WITH DC BRAKING:** Upon a START command, after a fault, or upon application of power, the drive will apply DC BRAKE VOLTAGE (Parameter 22) for the duration of DC BRAKE TIME (Parameter 21) prior to starting (or restarting) the motor.
- 05 **FLYING RESTART 1: LOW performance.** Slowest synchronization and lowest current level. This setting results in the smoothest synchronization.
- 06 **FLYING RESTART 2: MEDIUM performance.** Faster synchronization and higher current level. This setting allows faster synchronization while retaining smoothness.
- 07 **FLYING RESTART 3: HIGH performance.** Fastest synchronization and highest current level. This setting allows the fastest synchronization, but sacrifices smoothness.

The FLYING RESTART 1 - 3 settings allow the drive to start into a spinning load after a fault or upon application of input power. They differ in the time required to find the motor and the amount of current required to synchronize with it. The faster the drive attempts to find the motor, the more current is required.

When programmed for auto-restart, the drive will attempt three restarts after a fault. The interval between restart attempts is 15 seconds for setting 04, and 2 seconds for settings 05, 06 and 07. During the interval between restart attempts, the display will read "SP" to indicate Start Pending. If all three restart attempts fail, the drive will trip into FAULT LOCKOUT (displayed "LC") and require a manual reset. Refer to Section 16.0 - TROUBLESHOOTING.

**NOTE:** Settings 02 and 04 - 07 require a two-wire start/stop circuit to operate. The RUN contact must remain closed for the power-up start and auto-restart functions to operate.

## **P04 STOP METHOD**

- 01 **COAST TO STOP:** When a STOP command is given, the drive shuts off the output to the motor, allowing it to coast freely to a stop.
- 02 **COAST WITH DC BRAKE:** When a stop command is given, the drive will activate DC braking (after a delay of up to 2 seconds, depending on frequency) to help decelerate the load. Refer to Parameters: 21 - DC BRAKE TIME, and 22 - DC BRAKE VOLTAGE.
- 03 **RAMP TO STOP:** When a stop command is given, the drive will decelerate the motor to a stop at the rate determined by Parameter 20 - DECELERATION TIME.
- 04 **RAMP WITH DC BRAKE:** When a stop command is given, the drive will decelerate the motor down to 0.2 Hz (at the rate set by Parameter 20 - DECELERATION TIME) and then activate DC braking according to the settings of Parameters 21 - DC BRAKE TIME and 22 - DC BRAKE VOLTAGE. This is used to bring the load to a final stop, as the motor may still be turning slightly after the drive stops.

## **P05 STANDARD SPEED SOURCE**

This selects the speed reference source when the drive is in STANDARD speed mode. The following speed references can be selected:

- 01 **KEYPAD:** Use the ▲ and ▼ buttons to scroll to the desired speed.
- 02 **PRESET SPEED #1:** The drive will operate at the frequency set into Parameter 31.
- 03 **0 - 10 VDC:** The drive will respond to a 0-10 VDC signal wired to TB-2 and TB-5/25.
- 04 **4 - 20 mA:** The drive will respond to a 4-20 mA signal wired to TB-2 and TB-5/25.

## **P06 TB-14 OPEN COLLECTOR OUTPUT**

This selects the status indication for the open-collector output at TB-14. The terms “open” and “close” refer to the state of the internal transistor that activates the circuit. When the transistor is “closed”, TB-14 is at the same potential as TB-2, allowing current to flow.

- 01 **NONE:** Disables the open-collector output.
- 02 **RUN:** Closes upon a START command. Opens if the drive is in a STOP state, the drive faults, or input power is removed. DC braking is considered a STOP state.
- 03 **FAULT:** Closes if there is no fault condition. Opens if the drive faults, or input power is removed.
- 04 **INVERSE FAULT:** Closes if the drive faults. Opens if there is no fault condition.
- 05 **FAULT LOCKOUT:** Closes when input power is applied. Opens if three restart attempts are unsuccessful, or if input power is removed.

- 06 AT SET SPEED: Closes if the drive is within  $\pm 0.5$  Hz of the speed setpoint.
- 07 ABOVE PRESET SPEED #3: Closes if the output frequency exceeds the PRESET SPEED #3 setting. Opens if the output frequency is equal to or less than PRESET SPEED #3 (Parameter 33).
- 08 CURRENT LIMIT: Closes if the output current exceeds the CURRENT LIMIT setting. Opens if the output current is equal to or less than CURRENT LIMIT (see Parameter 25).
- 09 AUTOMATIC SPEED MODE: Closes if an AUTOMATIC (terminal strip) speed reference is active. Opens if a STANDARD (Parameter 5) speed reference is active.
- 10 REVERSE: Closes when reverse rotation is active. Opens when forward rotation is active. (see Parameter 17 - ROTATION DIRECTION).

#### **P08 TB-30 ANALOG OUTPUT**

Terminal TB-30 can be used as an analog output proportional to either output frequency or load. FREQUENCY SCALING (Parameter 40) or LOAD SCALING (Parameter 41) can be used to scale the output signal.

- 01 NONE
- 02 0-10 VDC FREQ
- 03 2-10 VDC FREQ
- 04 0-10 VDC LOAD
- 05 2-10 VDC LOAD

**NOTE:** The 2-10 VDC signal can be converted to a 4-20 mA signal by connecting a resistor in series with the signal such that the total load resistance is 500 Ohms. However, this output cannot be used with devices that derive power from a 4-20 mA signal.

#### **P09 TB-31 ANALOG OUTPUT**

Terminal TB-31 can be used as an analog output proportional to load, or as the control signal to activate the optional external Dynamic Braking module. LOAD SCALING (Parameter 41) can be used to scale the output signal when TB-31 is used as an analog output proportional to load.

- 01 NONE
- 02 0-10 VDC LOAD
- 03 2-10 VDC LOAD
- 04 DYNAMIC BRAKING: TB-31 becomes the “trigger” that activates the optional external Dynamic Braking module. Refer to the instructions included with the Dynamic Braking option.

**NOTE:** The 2-10 VDC signal can be converted to a 4-20 mA signal by connecting a resistor in series with the signal such that the total load resistance is 500 Ohms. However, this output cannot be used with devices that derive power from a 4-20 mA signal.

## **P10 TB-13A FUNCTION SELECT**

This selects the function of terminal TB-13A. Closing TB-13A to TB-4 (or opening in the case of settings 7 and 10) activates the selected function. The following functions can be selected:

- 01 NONE: Disables the TB-13A function.
- 02 0-10 VDC: Selects a 0-10 VDC signal (at TB-5/25) as the AUTO speed reference input.
- 03 4-20 mA: Selects a 4-20 mA signal (at TB-5/25) as the AUTO speed reference input.
- 04 PRESET SPEED #1: Selects PRESET SPEED #1 as the AUTO speed reference. The drive will operate at the frequency programmed into Parameter 31.
- 05 RUN REVERSE: Close TB-13A to TB-4 to RUN in the reverse direction, and open to STOP. This setting forces TB-12 to act as RUN FWD, requiring a maintained contact to RUN in the forward direction. TB-1 must be closed to TB-4 for this function to operate.
- 06 START REVERSE: Momentarily close TB-13A to TB-4 to START the drive in the reverse direction. Momentarily open TB-1 to TB-4 to STOP. This setting forces TB-12 to act as START FWD, requiring a momentary contact to START in the forward direction.
- 07 EXTERNAL FAULT: Sets TB-13A as a normally closed external fault input. If TB-13A is open with respect to TB-4, the drive will fault.
- 08 Factory Reserved: Equivalent to NONE (01).
- 09 DB FAULT: Sets TB-13A as a dynamic braking fault input when using the optional dynamic braking module. When this input is activated by the dynamic braking module, the drive will trip into a "dF" fault and the motor will coast to a stop. Refer to the manual included with the Dynamic Braking option.
- 10 AUXILIARY STOP: When TB-13A is opened with respect to TB-4, the drive will decelerate to a STOP (even if STOP METHOD is set to COAST) at the rate set into Parameter 42 - ACCEL/DECEL #2.
- 11 ACCEL/DECEL #2: Selects the acceleration and deceleration time programmed into Parameter 42 - ACCEL/DECEL #2.

**NOTE:** In order for the RUN REVERSE and START REVERSE functions to operate, Parameter 17 - ROTATION DIRECTION must be set to FORWARD AND REVERSE (02).

## **P11 TB-13B FUNCTION SELECT**

This selects the function of terminal TB-13B. Closing TB-13B to TB-4 (or opening in the case of setting 08) activates the selected function. The following functions can be selected:

- 01 NONE: Disables the TB-13B function.

- 02 0-10 VDC: Selects a 0-10 VDC signal (at TB-5/25) as the AUTO speed reference input.
- 03 4-20 mA: Selects a 4-20 mA signal (at TB-5/25) as the AUTO speed reference input.
- 04 PRESET SPEED #2: Selects PRESET SPEED #2 as the AUTO speed reference. The drive will operate at the frequency programmed into Parameter 32.
- 05 DECREASE FREQUENCY: Decreases the speed setpoint when using the MOP function. Refer to Section 10.6.
- 06 JOG FORWARD: Jog in the forward direction. In this mode, the drive will JOG at the speed programmed into Parameter 32 - PRESET SPEED #2.
- 07 JOG REVERSE: Jog in the reverse direction. In this mode, the drive will JOG at the speed programmed into Parameter 32 - PRESET SPEED #2.

**WARNING!**

When operating in JOG mode, the STOP terminal (TB-1), the AUXILIARY STOP function (see setting 08), and the STOP key on the optional remote keypad **WILL NOT** stop the drive. To stop the drive, remove the JOG command.

JOG REVERSE will operate the drive in reverse rotation even if ROTATION DIRECTION (Parameter 17) is set to FORWARD ONLY.

- 08 AUXILIARY STOP: When TB-13B is opened with respect to TB-4, the drive will decelerate to a STOP (even if STOP METHOD is set to COAST) at the rate set into Parameter 42 - ACCEL/ DECEL #2.

**NOTE:** If the drive is commanded to JOG while running, the drive will enter JOG mode and run at PRESET SPEED #2. When the JOG command is removed, the drive will STOP.

## **P12 TB-13C FUNCTION SELECT**

This selects the function of terminal TB-13C. Closing TB-13C to TB-4 (or opening in the case of setting 06) activates the selected function. The following functions can be selected:

- 01 NONE: Disables the TB-13C function.
- 02 0-10 VDC: Selects a 0-10 VDC signal (at TB-5/25) as the AUTO speed reference input.
- 03 4-20 mA: Selects a 4-20 mA signal (at TB-5/25) as the AUTO speed reference input.
- 04 PRESET SPEED #3: Selects PRESET SPEED #3 as the AUTO speed reference. The drive will operate at the frequency programmed into Parameter 33.
- 05 INCREASE FREQUENCY: Increases the speed setpoint when using the MOP function. Refer to Section 10.6.

- 06 EXTERNAL FAULT: Sets TB-13C as a normally closed external fault input. If TB-13C is open with respect to TB-4, the drive will fault.
- 07 Factory Reserved: Equivalent to NONE (01).
- 08 DB FAULT: Sets TB-13C as a dynamic braking fault input when using the optional dynamic braking module. When this input is activated by the dynamic braking module, the drive will trip into a "dF" fault and the motor will coast to a stop. Refer to the manual included with the Dynamic Braking option.
- 09 ACCEL/DECEL #2: Selects the acceleration and deceleration time programmed into Parameter 42 - ACCEL/DECEL #2.

### **P13 TB-15 OPEN COLLECTOR OUTPUT**

This selects the status indication for the open-collector output at TB-15, and has the same selections as Parameter 6 - TB-14 OPEN COLLECTOR OUTPUT.

### **P14 CONTROL**

This selects the source of START/STOP and direction commands.

- 01 TERMINAL STRIP & DEVICENET: The drive can be controlled from the terminal strip, or can be controlled using DeviceNet serial communications.
- 02 DEVICENET ONLY: The drive can only be controlled using DeviceNet serial communications.

### **P16 UNITS EDITING**

This allows parameter and keypad speed editing in whole units or tenths of units above 100. Below 100, the value can always be changed by tenths of units.

- 01 TENTHS OF UNITS: The value can always be changed by tenths of units (up to a value of 1000). If the ▲ or ▼ button is pressed and held, the value will change by tenths of units until the next whole unit is reached, and then the value will change by whole units. Refer to Section 13.1.
- 02 WHOLE UNITS: The value can be changed by tenths of units until 99.9 is reached. Above 99.9, the value will change in whole unit increments only. Below a value of 100, if the ▲ or ▼ button is pressed and held, the value will change by tenths of units until the next whole unit is reached, and then the value will change by whole units.

### **P17 ROTATION DIRECTION**

- 01 FORWARD ONLY: The drive will only allow rotation in the forward direction. However, JOG REVERSE (see Parameter 11) will still operate even if FORWARD ONLY is selected.
- 02 FORWARD AND REVERSE: The drive will allow rotation in both directions.

## **P19 ACCELERATION TIME**

This parameter sets the acceleration rate for all of the speed reference sources (keypad, speed pot, 4-20 mA, 0-10 VDC, jog, MOP, and preset speeds). This setting is the time to accelerate from 0 Hz to the BASE FREQUENCY (Parameter 27).

## **P20 DECELERATION TIME**

This parameter sets the deceleration rate for all of the speed reference sources (keypad, speed pot, 4-20 mA, 0-10 VDC, jog, MOP, and preset speeds). This setting is the time to decelerate from BASE FREQUENCY to 0 Hz. If the drive is set for COAST TO STOP (setting 01 or 02 in Parameter 04), this parameter will have no effect when a STOP command is given.

## **P21 DC BRAKE TIME**

This determines the length of time that the DC braking voltage is applied to the motor. The DC BRAKE TIME should be set to the lowest value that provides satisfactory operation in order to minimize motor heating.

## **P22 DC BRAKE VOLTAGE**

This sets the magnitude of the DC braking voltage, in percentage of the nominal DC Bus voltage (DC Bus = input AC voltage X 1.414). The point at which the DC braking is activated depends on the selected STOP METHOD (Parameter 04):

If COAST WITH DC BRAKE is selected, the DC braking is activated after a time delay of up to 2 seconds, depending on the output frequency at the time of the STOP command. In this case, the DC braking is the only force acting to decelerate the load.

If RAMP WITH DC BRAKE is selected, braking is activated when the output frequency reaches 0.2 Hz. In this case, the drive decelerates the load to a near stop and the DC braking is used to bring the load to a final stop.

## **P23 MINIMUM FREQUENCY**

This sets the minimum output frequency of the drive for all speed reference sources except the PRESET SPEEDS (Parameters 31-37).

When using a 0-10 VDC or 4-20 mA analog speed reference signal, this parameter also sets the drive speed that corresponds to the minimum analog input (0 VDC or 4 mA).

**NOTE:** If this parameter is changed while the drive is running, the new value will not take effect until the drive is stopped.

## **P24 MAXIMUM FREQUENCY**

This sets the maximum output frequency of the drive for all speed reference sources, and is used with MINIMUM FREQUENCY (Parameter 23) to define the operating range of the drive.

When using a 0-10 VDC or 4-20 mA analog speed reference signal, this parameter also sets the drive speed that corresponds to the maximum analog input (10 VDC or 20 mA).

**NOTE 1:** On drives equipped with the High Output Frequency option, this parameter can be set up to 999.9 Hz.

**NOTE 2:** If this parameter is changed while the drive is running, the new value will not take effect until the drive is stopped.

## **P25 CURRENT LIMIT**

This sets the maximum allowable output current of the drive. The maximum setting is either 180% or 150%, depending on whether LINE VOLTAGE SELECTION (Parameter 01) is set to HIGH or LOW.

The drive will enter current limit when the load demands more current than the CURRENT LIMIT setting. When this happens, the drive will reduce the output frequency in an attempt to reduce the output current. When the overload condition passes, the drive will accelerate the motor back up to the speed setpoint.

## **P26 MOTOR OVERLOAD**

The SCD Series is UL approved for solid state motor overload protection, and therefore does not require a separate thermal overload relay for single motor applications.

The drive contains an adjustable thermal overload circuit that protects the motor from excessive overcurrent. This circuit allows the drive to deliver up to 150% current for one minute. If the overload circuit "times out", the drive will trip into an OVERLOAD fault (displayed as "PF").

MOTOR OVERLOAD should be set to the ratio (in percent) of the motor current rating to the drive current rating in order to properly protect the motor. See the example below.

**Example:** A 3 HP, 480 Vac drive with a 4.8 Amp rating is operating a 2 HP motor with a current rating of 3.4 Amps. Dividing the motor current rating by the drive current rating yields 71% ( $3.4 / 4.8 = 0.71 = 71\%$ ), so this parameter should be set to 71%.

## **P27 BASE FREQUENCY**

The BASE FREQUENCY determines the V/Hz ratio by setting the output frequency at which the drive will output full voltage to the motor. In most cases, the BASE FREQUENCY should be set to match the motor's rated frequency.

**Example:** A 460 Vac, 60 Hz motor requires a V/Hz ratio of 7.67 ( $460 \text{ V} / 60 \text{ Hz} = 7.67 \text{ V/Hz}$ ) to produce full torque. Setting the BASE FREQUENCY to 60 Hz causes the drive to output full voltage (460 Vac) at 60 Hz, which yields the required 7.67 V/Hz. Output voltage is proportional to output frequency, so the 7.67 V/Hz ratio is maintained from 0 - 60 Hz, allowing the motor to produce full torque from 2 Hz (below 2 Hz there is less torque due to slip) up to 60 Hz.

**NOTE:** If this parameter is changed while the drive is running, the new value will not take effect until the drive is stopped.

**P28 FIXED BOOST**

FIXED BOOST increases starting torque by increasing the output voltage when operating below half of the base frequency, which increases the V/Hz ratio (see diagram below). For better out-of-the-box performance, SCD Series drives are shipped with a setting that is different from the factory default, as seen in the table below. If a factory reset is performed, FIXED BOOST will default to 1.0 %.

HP	FACTORY SETTING	HP	FACTORY SETTING
0.25 - 1	5.3 %	7.5	2.7 %
1.5	4.4 %	10	2.4 %
2	4.4 %	15	2.2 %
3	3.6 %	20	2.0 %
5	3.0 %	25	1.8 %

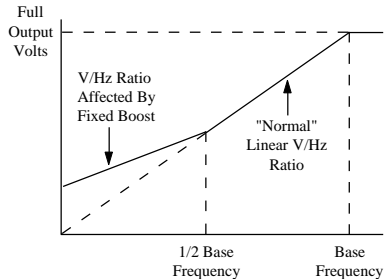

**P29 ACCELERATION BOOST**

ACCELERATION BOOST helps accelerate high-inertia loads. During acceleration, the output voltage is increased to increase motor torque. Once the motor reaches the new speed setpoint, the boost is turned off and the output voltage returns to the normal value.

**P30 SLIP COMPENSATION**

SLIP COMPENSATION is used to counteract changes in motor speed (slip) caused by changes in load. In a standard AC induction motor, the shaft speed decreases as load increases, and increases as load decreases. By increasing or decreasing the output frequency in response to an increasing or decreasing load, the slip is counteracted and speed is maintained. Most standard NEMA B motors have a 3% slip rating.

**P31-P37 PRESET SPEED #1 - #7**

Preset speeds are activated by contact closures between TB-4 and TB-13A, 13B, and 13C. The TB-13 terminals must be programmed as preset speed selects using Parameters 10-12.

**NOTE 1:** Preset speeds can operate below the frequency defined by the minimum frequency parameter (Parameter 23). The range of adjustment for the preset speeds is from 0 Hz to the maximum frequency (Parameter 24).

Refer to the table below for activation of the preset speeds using the TB-13 terminals.

SPEED#	TB - 13A	TB - 13B	TB - 13C
1	CLOSED	OPEN	OPEN
2	OPEN	CLOSED	OPEN
3	OPEN	OPEN	CLOSED
4	CLOSED	CLOSED	OPEN
5	CLOSED	OPEN	CLOSED
6	OPEN	CLOSED	CLOSED
7	CLOSED	CLOSED	CLOSED

**NOTE 2:** When a TB-13 terminal is programmed for a function other than a preset speed select, it is considered OPEN for the table above.

Preset Speed #6 and #7 can also be used as skip frequencies to restrict the drive from operating at frequencies that cause vibration in the system. See Parameter 38 below.

### **P38 SKIP BANDWIDTH**

The SCD drive has two skip frequencies that can be used to lock out critical frequencies that cause mechanical resonance in the system. Once SKIP BANDWIDTH is set to a value other than 0.0 Hz, the skip frequencies are enabled. When the skip frequency function is enabled, PRESET SPEED #6 and #7 are used as the skip frequencies. SKIP BANDWIDTH sets the range above the skip frequencies that the drive will not operate within.

**Example:** The critical frequency is 23 Hz, and it is desired to skip a frequency range of 3 Hz above and below the critical frequency (therefore the skip range is 20 to 26 Hz). PRESET SPEED #6 or #7 would be set to 20 Hz, and the SKIP BANDWIDTH would be set to 6.0 Hz.

If the drive is running at a speed below the skip range, and it is given a speed command that is within the skip range, the drive will accelerate to the start of the skip range (20 Hz in the example) and run at that speed until the speed command is greater than or equal to the "top" of the skip range. The drive will then accelerate through the skip range to the new speed. Likewise, if the drive is running at a speed above the skip range, and it is given a speed command that is within the skip range, the drive will decelerate to the "top" of the skip range (26 Hz in the example) and run at that speed until the speed command is less than or equal to the "bottom" of the skip range. The drive will then decelerate through the skip range to the new speed.

**NOTE:** PRESET SPEEDS #6 and #7 can still be used as preset speeds even if they are also being used as skip frequencies.

### **P39 SPEED SCALING**

This scales the display to indicate speed or user units other than frequency. This parameter should be set to the desired display value when the drive output is 60 Hz. The highest setting is 6500, and the highest value that can be displayed is 6553.6.

**Example:** A machine produces 175 parts per hour when the motor is running at 60 Hz. Setting the SPEED SCALING to 175 will calibrate the drive's display to read 175 when the motor is running at 60 Hz. This is a linear function, so at 30 Hz the display would read 87.5, and at 120 Hz, the display would read 350.

**NOTE:** If SPEED SCALING is set such that the maximum displayable value (6553.6) is exceeded, the display will flash "9999" to indicate that the value is out of range. For example, if SPEED SCALING is set to 6000, the drive will display 6000 when it is running at 60 Hz. If the speed is increased past 65.5 Hz (at 65.5 Hz, the scaled value would be 6550), the display will flash "9999" because a scaled value above 6553.6 cannot be displayed.

#### **P40 FREQUENCY SCALING**

This scales the analog output signal at TB-30 when it is configured for a frequency output. This setting is the output frequency that is indicated when the output signal measures 10 VDC.

**Example:** A 0-5 VDC signal is required to indicate 0-60 Hz. Setting this parameter to 120 Hz would yield 10 VDC at 120 Hz, and 5 VDC at 60 Hz. If the drive only operates up to 60 Hz, the output signal at TB-30 is limited to the desired 0-5 VDC.

#### **P41 LOAD SCALING**

This scales the analog output signal at TB-30 and/or TB-31 when they are configured for a load output. This setting is the load (in %) that is indicated when the output signal measures 10 VDC.

**Example:** A 0-10 VDC signal is required to indicate 0-150% load. Setting this parameter to 150% will yield 10 VDC at 150% load.

#### **P42 ACCEL / DECEL #2**

This parameter sets the second acceleration and deceleration rate of the drive. To activate this acceleration and deceleration rate, use terminal TB-13A, TB-13B or T-13C. TB-13A and TB-13B can be set to AUXILIARY STOP which will cause the drive to decelerate to a stop according to the time programmed in this parameter. TB-13C can be set to ACCEL/DECEL #2, which causes the drive to accelerate and decelerate according to the time programmed in this parameter.

#### **P44 PASSWORD**

This allows the PASSWORD to be changed to any number between 000 and 999. Setting PASSWORD to 000 disables the password function.

**NOTE:** The factory default password is 225.

#### **P47 CLEAR FAULT HISTORY**

01 MAINTAIN: Maintains the FAULT HISTORY (Parameter 50) entries for troubleshooting.

02 CLEAR: Erases the FAULT HISTORY (Parameter 50) entries.

## **P48 PROGRAM SELECTION**

This is used to select whether the drive will operate according to the user settings or the optional OEM default settings, and to reset the parameters to default settings. Refer to Section 13.2.

- 01 OPERATE WITH USER SETTINGS: The drive will operate according to the user settings. Operation in USER mode allows the parameter values to be changed to suit any application.
- 02 OPERATE WITH OEM DEFAULTS: The drive will operate according to the optional OEM default settings, which configure the drive for a specific application. When operating in OEM mode, the parameter values can be viewed, but not changed. If an attempt is made to change a parameter setting, the display will flash "GE". If the drive is not programmed with OEM default settings, the display will flash "GF" if this option is selected.
- 03 RESET OEM: Resets the user parameters to the OEM default settings. If the drive is not programmed with OEM default settings, the display will flash "GF" if this option is selected.
- 04 RESET 60: Resets the user parameters to the factory defaults for a 60 Hz base frequency.
- 05 RESET 50: Resets the user parameters to the factory defaults for a 50 Hz base frequency. Parameters 24, 27, and 40 will reset to 50.0 Hz.
- 06 TRANSLATE: If an EPM from a drive with a previous parameter version is installed in a new drive, the new drive will function like the previous version drive, but none of the parameter settings can be changed ("cE" will be displayed if this is attempted). The TRANSLATE function converts the EPM to the new parameter version so that the parameters can be changed, but it also retains the old parameter settings so the new drive will operate like the old drive without having to re-program all of the parameters.

**NOTE 1:** If the user parameters are reset to the OEM defaults (using the RESET OEM option), and then OPERATE WITH USER SETTINGS is selected, the USER settings will be the same as the OEM default settings. This allows the drive to operate as if it was in OEM mode, but the parameter values can be changed. This is useful if some of the OEM default settings need to be fine-tuned for proper operation. The new parameter values are not actually stored as new OEM default settings however; they are simply stored as new USER settings. Therefore, if the parameters are reset to the OEM defaults again, the parameters that were changed will be reset to their "old" value. The optional EPM Programmer is required to change OEM default settings. Refer to Section 13.2.

**NOTE 2:** Only the TRANSLATE (06) function can be performed while the drive is running. The display will flash "Er" if an attempt is made to select any other function while the drive is running.

## **P50      FAULT HISTORY**

The FAULT HISTORY stores the last eight faults that tripped the drive. Refer to Section 16.0 - TROUBLESHOOTING for a list of the faults and possible causes.

Use the ▲ and ▼ buttons to scroll through the fault entries. The far left digit of the display will be the fault number and the remaining two digits will be the fault code. The faults are stored from newest to oldest, with the first fault shown being the most recent.

The display will read “\_ \_” if the FAULT HISTORY does not contain any fault messages.

## **P51      SOFTWARE VERSION**

This displays the software version number for the control board software. This information is useful when contacting the factory for programming or troubleshooting assistance.

The software version is displayed in two parts which alternate. The first part is the software version, and the second part is the revision number. For example, if the display shows "79-" and "-03", this indicates that the drive contains the third revision of version 79 software.

## **P52      DC BUS VOLTAGE**

This displays the DC bus voltage in percent of nominal. Nominal DC bus voltage is determined by multiplying the drive's nameplate input voltage rating by 1.4.

## **P53      MOTOR VOLTAGE**

This displays the output voltage in percent of the drive's nameplate output voltage rating.

## **P54      MOTOR LOAD**

This displays the motor load in percent of the drive's output current rating.

## **P55      0-10 VDC ANALOG INPUT**

This displays the level of the 0-10 VDC analog input signal at TB-5/25. A reading of 100% indicates a 10 VDC input at TB-5/25.

## **P56      4-20 mA ANALOG INPUT**

This displays the level of the 4-20 mA analog input signal at TB-5/25. A reading of 20% indicates a 4 mA input at TB-5/25, and a reading of 100% indicates a 20 mA input at TB-5/25.

## **P57      TERMINAL STRIP STATUS**

This indicates the status of several terminals using the vertical segments of the LED display. An illuminated segment indicates that the particular terminal is closed with respect to TB-4. The CHARGE RELAY is not a terminal, and should always be illuminated. See the diagram below:

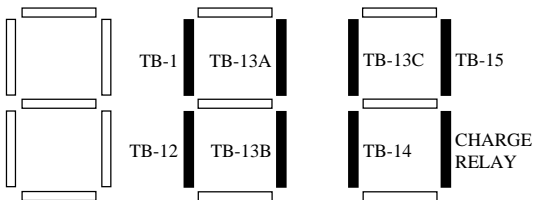

**P58 KEYPAD AND PROTECTION STATUS**

This indicates the status of the buttons on the keypad, and the status of the protective circuitry in the drive, using the horizontal segments of the LED. An illuminated segment indicates that the corresponding button is pressed, or the protective circuit is active. See the diagram below:

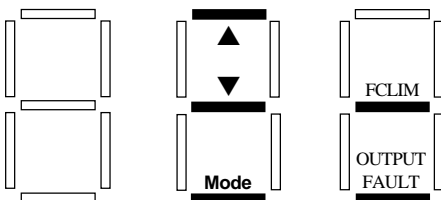

**NOTE:** FCLIM is an abbreviation for Fast Current Limit.

**P59 TB-30 ANALOG OUTPUT**

This displays the level of the analog output signal at TB-30. A reading of 100% indicates that the output is 10 VDC.

**P60 TB-31 ANALOG OUTPUT**

This displays the level of the analog output signals at TB-31. A reading of 100% indicates that the output is 10 VDC.

**P85 MOTOR RATED RPM**

When using the DeviceNet interface, this must be set to match the nameplate RPM of the motor.

**P86 MOTOR RATED CURRENT**

When using the DeviceNet interface, this must be set to match the nameplate full load amperage (FLA) rating of the motor.

**P87 MOTOR RATED VOLTAGE**

When using the DeviceNet interface, this must be set to match the nameplate voltage rating of the motor.

**P88 MOTOR RATED FREQUENCY**

When using the DeviceNet interface, this must be set to match the nameplate frequency rating of the motor.

**P89 DRIVE RATED CURRENT**

When using the DeviceNet interface, this must be set to match the nameplate output current rating of the drive.

**P90 DRIVE RATED VOLTAGE**

When using the DeviceNet interface, this must be set to match the nameplate maximum output voltage rating of the drive.

**Example:** A 5 Hp, 400/480 Vac SCD drive (SD450) is being used with a 5 Hp, 230/460 Vac, 60 Hz, 1800 RPM motor that is rated 7.1 amps. Parameters 85-90 would be set as follows:

P85	MOTOR RATED RPM	1800 RPM
P86	MOTOR RATED CURRENT	7.1 AMPS
P87	MOTOR RATED VOLTAGE	460 VOLTS
P88	MOTOR RATED FREQUENCY	60 Hz
P89	DRIVE RATED CURRENT	7.6 AMPS
P90	DRIVE RATED VOLTAGE	480 VOLTS

**C00 DEVICENET NODE ADDRESS**

**C01 DEVICENET BAUD RATE**

**C02 DEVICENET LOSS ACTION**

**C03 DEVICENET OUTPUT ASSEMBLY SELECTION**

**C04 DEVICENET INPUT ASSEMBLY SELECTION**

**C05 DEVICENET CUSTOM INPUT ASSEMBLY WORD 0**

**C06 DEVICENET CUSTOM INPUT ASSEMBLY WORD 1**

**C07 DEVICENET CUSTOM INPUT ASSEMBLY WORD 2**

**C08 DEVICENET CUSTOM INPUT ASSEMBLY WORD 3**

**C09 DEVICENET MOTOR TYPE**

**C10 DEVICENET DIAGNOSTICS**

**NOTE:** Refer to Appendix B - DeviceNet Control for more information on Parameters 85-90 and C00 - C10.

## 16.0 TROUBLESHOOTING

To aid in troubleshooting, Parameters 50 through 60 can be accessed without entering the PASSWORD. Simply press the **Mode** button twice to “skip” over the PASSWORD prompt, and “P50” will be displayed to indicate that the parameter menu has been entered and Parameter 50 (FAULT HISTORY) can be viewed. The **▲** and **▼** buttons can then be used to scroll from Parameter 50 to Parameter 60. Once the desired parameter is found, press the **Mode** button to view its “contents”. When finished, press **Mode** to exit the parameter menu. An example is shown below:

Press **Mode** once

Display reads "00"

Upper right decimal point blinks

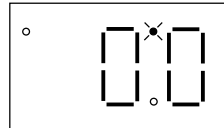

Press **Mode** again

Display reads "P50" (FAULT HISTORY)

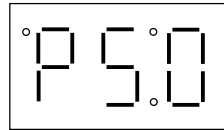

Use **▲** and **▼** to scroll to the desired parameter number

(In this example Parameter 54 has been selected, which is MOTOR LOAD)

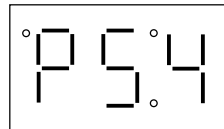

Press **Mode** to view parameter contents  
(77 = 77% LOAD)

Upper right decimal point blinks

Press **Mode** again to exit

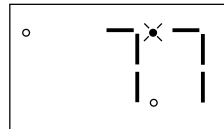

In the example above, Parameter 54 - MOTOR LOAD is being viewed. The “77” in the example indicates that the load on the motor is 77% of the output current rating of the drive.

The table below lists the fault conditions that will cause the drive to shut down, as well as some possible causes. Please contact the factory for more information on troubleshooting faults.

<b>FAULT MESSAGES</b>	
<b>FAULT</b>	<b>DESCRIPTION &amp; POSSIBLE CAUSES</b>
AF	High Temperature Fault: Ambient temperature is too high; Cooling fan has failed (if equipped).
CF	Control Fault: A blank EPM, or an EPM with corrupted data has been installed. Perform a factory reset using Parameter 48 - PROGRAM SELECTION.
cF	Incompatibility Fault: An EPM with an incompatible parameter version has been installed. Either remove the EPM or perform a factory reset (Parameter 48) to change the parameter version of the EPM to match the parameter version of the drive.
dF	Dynamic Braking Fault: The drive has sensed that the dynamic braking resistors are overheating and shuts down to protect the resistors.
EF	External Fault: TB-13A and/or TB-13C is set as an External Fault input and TB-13A and/or TB-13C is open with respect to TB-2. Refer to Parameter 10 and/or 12.
GF	Data Fault: User data and OEM defaults in the EPM are corrupted.
HF	High DC Bus Voltage Fault: Line voltage is too high; Deceleration rate is too fast; Overhauling load. For fast deceleration or overhauling loads, dynamic braking may be required.
JF	Network Fault: The watchdog timer has timed out, indicating that the network link has been lost.
LF	Low DC Bus Voltage Fault: Line voltage is too low.
nF	DeviceNet Fault: The DeviceNet master has commanded the drive to trip into a fault.
OF	Output Transistor Fault: Phase to phase or phase to ground short circuit on the output; Failed output transistor; Boost settings are too high; Acceleration rate is too fast.
PF	Current Overload Fault: VFD is undersized for the application; Mechanical problem with the driven equipment.
SF	Single-phase Fault: Single-phase input power has been applied to a three-phase drive.
UF	Start Fault: Start command was present when the drive was powered up. Must wait 2 seconds after power-up to apply Start command if START METHOD is set to NORMAL.
F1	EPM Fault: The EPM is missing or damaged.
F2 - F9, Fo	Internal Faults: The control board has sensed a problem - consult factory.

To clear a fault, issue a STOP command on the terminal strip. The fault will only clear if the condition that caused the fault has passed. For example, if the drive trips on a LOW DC BUS VOLTAGE FAULT (LF) due to low input voltage, the fault cannot be cleared until the input voltage returns to a normal level.

If the drive is programmed to automatically restart after a fault (see Parameter 03), the drive will attempt to restart three times after a fault (the drive will not restart after CF, cF, GF, F1, F2-F9, or Fo faults). If all three restart attempts are unsuccessful, the drive will trip into FAULT LOCKOUT (LC), which requires a manual reset as described above.

## 17.0 SCD DISPLAY MESSAGES

The following describes the various displays and messages that can appear on the SCD drive.

### 17.1 SPEED DISPLAY

If the drive is in a STOP state (indicated by "- -" on the display), and the commanded speed is changed, the display will show the commanded speed, and the upper left decimal point will turn on solid. About five seconds after a change is made, the display will begin to alternate between the commanded speed value and the "- -" display. If the **Mode** button is pressed, the display will stop alternating and show the "- -" display only.

When the drive is given a START command, the displayed speed will start increasing as the drive accelerates up to the commanded speed. If the commanded speed is changed while the drive is running, the display will show the commanded speed rather than the actual speed, until the actual speed reaches the commanded speed.

If the commanded speed is changed faster than the drive can accelerate or decelerate, the upper left decimal point will blink to indicate that the the drive is accelerating or decelerating to the new speed. Once the actual speed reaches the commanded speed, the upper left decimal point will turn on solid for 5 seconds and then turn off to indicate that the commanded speed has been reached, and that the display is now showing the actual speed.

### 17.2 CHANGING THE SPEED REFERENCE SOURCE

When the speed source is changed while the drive is running, the display will flash the message for the new speed source to indicate that the new speed source is active. Also, if the drive is being controlled from a speed source other than the ▲ and ▼ buttons (0-10 VDC, 4-20 mA, etc), and one of the ▲ or ▼ buttons is pressed, the display will flash the present speed source message to indicate that the ▲ and ▼ buttons are invalid.

**Example 1:** The drive is running and the present speed source is the keypad. TB-13A is programmed to select a 4-20 mA signal as the speed source. When TB-13A is closed to TB-4, the display will flash "EI" to indicate that the speed source has changed to the 4-20 mA signal. If the contact between TB-13A and TB-4 is opened, the display will flash "CP" to indicate that the speed source has changed back to the ▲ and ▼ buttons.

**Example 2:** The speed source is a 0-10 VDC signal. If the ▲ or ▼ button is pushed, the display will flash "EU" to indicate that the present speed source is the 0-10 VDC signal and that the ▲ and ▼ buttons are invalid.

Refer to the table below for the possible speed reference source displays:

## SPEED SOURCE DISPLAYS

DISPLAY	DESCRIPTION
CP	CONTROL PAD: Speed is set using the ▲ and ▼ buttons on the front of the drive.
EI	EXTERNAL CURRENT: Speed is controlled by a 4-20 mA signal wired to TB-25 and TB-2.
EU	EXTERNAL VOLTAGE: Speed is controlled by a 0-10 VDC signal wired to TB-5 and TB-2.
JG	JOG: The drive is in Jog mode, and the speed is set by Preset Speed #2 (Parameter 32).
dn	DEVICENET: Speed is controlled from the DeviceNet interface.
OP	MOP (Motor Operated Pot): Contacts wired to TB-13B and TB-13C are used to increase and decrease the drive speed.
Pr1 - Pr7	PRESET SPEEDS #1-7: Speed is set by the indicated Preset Speed (Parameters 31-37).

**NOTE:** The speed source displays will flash when the speed reference source is changed while the drive is running to indicate that the new speed reference source is active.

### 17.3 STATUS AND WARNING MESSAGES

## STATUS AND WARNING MESSAGES

DISPLAY	DESCRIPTION
br	DC BRAKING: The DC braking circuit is activated.
CL	CURRENT LIMIT: The output current has exceeded the CURRENT LIMIT setting (Parameter 25) and the drive is reducing the output frequency to reduce the output current. If the drive remains in CURRENT LIMIT for too long, it can trip into a CURRENT OVERLOAD fault (PF).
Er	ERROR: Invalid data has been entered or an invalid command was attempted.
GE	"GE" will be displayed if an attempt is made to change the OEM default settings when the drive is operating in the OEM mode (see Parameter 48).
GF	If "GF" is displayed when a RESET OEM is attempted, it indicates that the OEM defaults in the EPM are corrupted. If "GF" is displayed upon power-up, it indicates that the OEM defaults and the user settings in the EPM are corrupted. Refer to Section 13.2.
LC	FAULT LOCKOUT: The drive has failed three restart attempts and now requires a manual reset.
SP	START PENDING: "SP" blinks during the interval between restart attempts.
	DECEL OVERRIDE (both upper decimal points blinking): The drive has stopped decelerating to avoid tripping into an HF fault due to regenerative energy from the motor.

## APPENDIX A - THROUGH-HOLE MOUNT OPTION

The Through-Hole Mount option for the SCD drive allows the drive to be mounted with the heatsink outside of the enclosure for better heat dissipation. This is done by using a special heatsink that mounts to the outside of the enclosure. The drive (which has a flat plate instead of a heatsink) is mounted to the heatsink from the inside of the enclosure. This requires cutting a hole in the enclosure that is slightly smaller than the heatsink. Up to NEMA 4X can be achieved with this option. Panel cutout and mounting hole dimensions are provided below for the different drive sizes.

**NOTE 1:** The temperature inside the enclosure must be maintained at 50°C or less, and the ambient temperature outside of the enclosure must be 40°C or less. Refer to Section 5.0 - SCD RATINGS for heat loss information.

**NOTE 2:** Cutout view is shown from the drive side (inside) of the panel.

### THROUGH-HOLE DRAWING FOR MODELS UP TO 10 HP (7.5 kW)

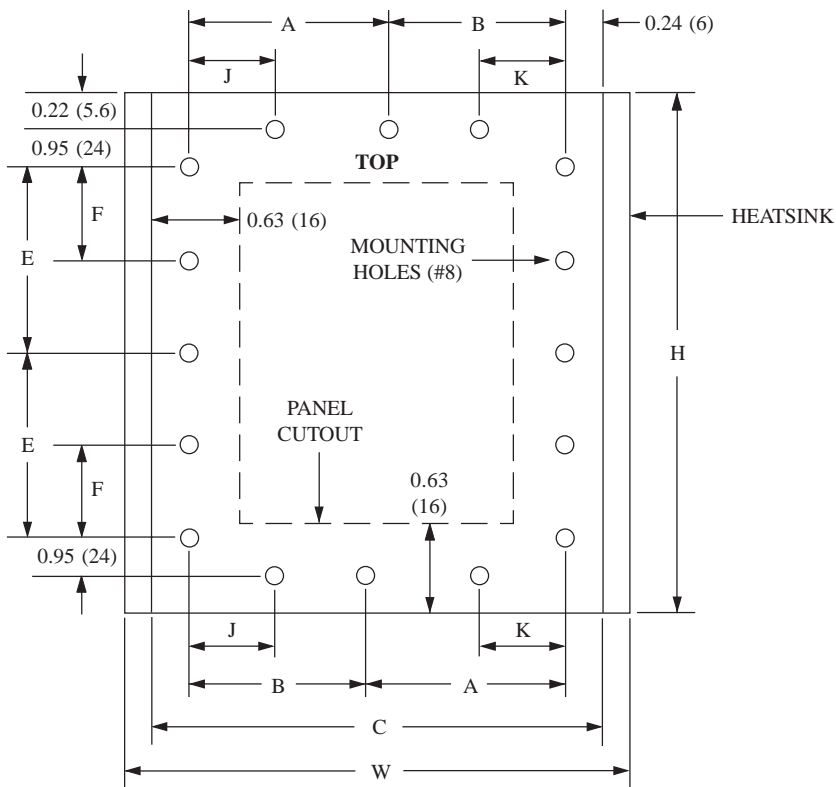

**THROUGH-HOLE MOUNT DIMENSIONS FOR MODELS UP TO 10 HP (7.5 kW)**

HP (kW)	MODEL	H	W	A	B	C	E	F	J	K
1 (0.75)	SD210YF	7.72 (196)	6.80	2.76	2.76	6.00	2.69	N/A	N/A	N/A
	SD210F	7.72	6.80	2.76	2.76	6.00	2.69	N/A	N/A	N/A
	SD410F	7.72	6.80	2.76	2.76	6.00	2.69	N/A	N/A	N/A
	SD510F	7.72	6.80	2.76	2.76	6.00	2.69	N/A	N/A	N/A
1.5 (1.1)	SD215YF	7.72	6.80	2.76	2.76	6.00	2.69	N/A	N/A	N/A
	SD215F	7.72	6.80	2.76	2.76	6.00	2.69	N/A	N/A	N/A
	SD415F	7.72	6.80	2.76	2.76	6.00	2.69	N/A	N/A	N/A
2 (1.5)	SD220YF	7.72	6.80	2.76	2.76	6.00	2.69	N/A	N/A	N/A
	SD220F	7.72	6.80	2.76	2.76	6.00	2.69	N/A	N/A	N/A
	SD420F	7.72	6.80	2.76	2.76	6.00	2.69	N/A	N/A	N/A
	SD520F	7.72	6.80	2.76	2.76	6.00	2.69	N/A	N/A	N/A
3 (2.2)	SD230YF	7.72	8.54	3.80	3.46	7.74	2.69	N/A	1.72	1.75
	SD230F	7.72	8.54	3.80	3.46	7.74	2.69	N/A	1.72	1.75
	SD430F	7.72	8.54	3.80	3.46	7.74	2.69	N/A	1.72	1.75
	SD530F	7.72	8.54	3.80	3.46	7.74	2.69	N/A	1.72	1.75
5 (3.7)	SD250YF	9.59	11.14	5.06	4.60	10.14	3.63	N/A	2.32	2.32
	SD250F	7.72	8.54	3.80	3.46	7.74	2.69	N/A	1.72	1.75
	SD450F	7.72	8.54	3.80	3.46	7.74	2.69	N/A	1.72	1.75
	SD550F	7.72	8.54	3.80	3.46	7.74	2.69	N/A	1.72	1.75
7.5 (5.5)	SD275F	11.59	11.14	5.06	4.60	10.14	4.63	2.31	2.32	2.32
	SD475F	9.59	11.14	5.06	4.60	10.14	3.63	N/A	2.32	2.32
	SD575F	9.59	11.14	5.06	4.60	10.14	3.63	N/A	2.32	2.32
10 (7.5)	SD2100F	15.59	11.14	5.06	4.60	10.14	6.63	3.31	1.94	2.32
	SD4100F	11.59	11.14	5.06	4.60	10.14	4.63	2.31	2.32	2.32
	SD5100F	11.59	11.14	5.06	4.60	10.14	4.63	2.31	2.32	2.32

**NOTE 1:** The N/A indication for dimensions F, J, and K indicate that the heatsinks for these models have fewer mounting holes than shown in the drawing.

**NOTE 2:** For mm, multiply inches listed above by 25.4.

### THROUGH-HOLE DRAWING FOR 15 HP (11 kW) AND 20 HP (15 kW) MODELS

This drawing applies to the following models only: SD2150F, SD4150F, SD5150F, SD4200F, and SD5200F.

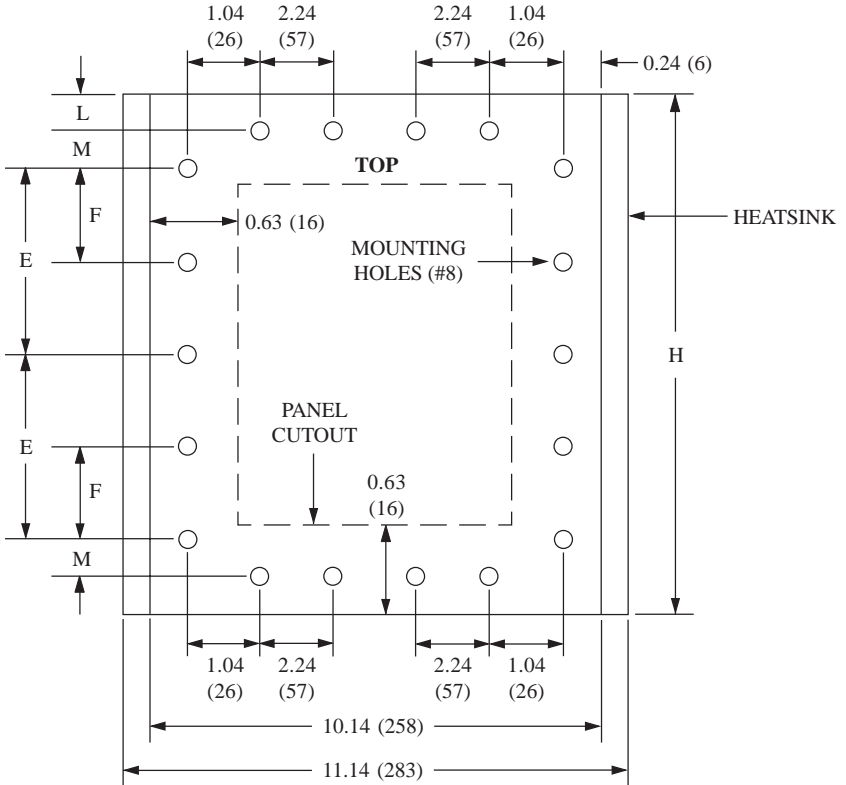

### THROUGH-HOLE CUTOUT DIMENSIONS FOR 15 HP (11 kW) & 20 HP (15 kW) MODELS

HP (kW)	MODEL	H	E	F	L	M
15	SD2150F	18.09 (459)	6.03 (153)	3.02 (77)	0.50 (13)	2.52 (64)
(11)	SD4150F	15.59 (396)	6.03 (153)	3.31 (84)	0.22 (5.6)	0.95 (24)
	SD5150F	15.59 (396)	6.03 (153)	3.31 (84)	0.22 (5.6)	0.95 (24)
20	SD4200F	18.09 (459)	6.03 (153)	3.02 (77)	0.50 (13)	2.52 (64)
(15)	SD5200F	18.09 (459)	6.03 (153)	3.02 (77)	0.50 (13)	2.52 (64)



## APPENDIX B - DEVICENET™ CONTROL

### TABLE OF CONTENTS

<b>B.1</b>	<b>GENERAL</b> .....	58
<b>B.2</b>	<b>INITIAL CONFIGURATION</b> .....	58
<b>B.3</b>	<b>BASIC MODE OF OPERATION</b> .....	59
	SAMPLE SETUP AND WIRING FOR DEVICENET™ CONTROL.....	59
	SAMPLE OF SETUP AND TEST RUNS USING RSNETWORX™.....	60
<b>B.4</b>	<b>DEVICENET™ IMPLEMENTATION FOR SCD SERIES DRIVES</b> .....	61
<b>B.5</b>	<b>CLASS IMPLEMENTATION DETAILS</b> .....	62
	IDENTITY OBJECT - CLASS 0x01.....	62
	MESSAGE ROUTER OBJECT - CLASS 0x02.....	62
	DEVICENET OBJECT - CLASS 0x03.....	63
	ASSEMBLY OBJECT - CLASS 0x04.....	64
	DEVICENET CONNECTION OBJECT - CLASS 0x05.....	65
	PARAMETER OBJECT - CLASS 0x0F.....	69
	PARAMETER GROUP OBJECT - CLASS 0x10.....	73
	MOTOR DATA OBJECT - CLASS 0x28.....	77
	CONTROL SUPERVISOR OBJECT - CLASS 0x29.....	77
	AC / DC DRIVE OBJECT - CLASS 0x2A.....	80
	ACKNOWLEDGE HANDLER OBJECT - CLASS 0x2B.....	81
<b>B.6</b>	<b>DESCRIPTION OF DEVICENET™ PARAMETERS</b> .....	81
<b>B.7</b>	<b>NETWORK TROUBLESHOOTING</b> .....	94

DeviceNet is a Trademark of the Open DeviceNet Vendor Association, Inc.  
RSNetWorx is a Trademark of Rockwell Software, Inc.

## B.1 GENERAL

The following information is provided to allow the SCD Series drive to operate on a DeviceNet™ network; it is not intended to explain how DeviceNet™ itself works. Therefore, a working knowledge of DeviceNet™ is assumed, as well as familiarity with the operation of the SCD Series drive.

## B.2 INITIAL CONFIGURATION

The SCD Series drive is equipped with a 5 pin female connector that should be used for connecting to the DeviceNet™ network. The wires should be connected as shown:

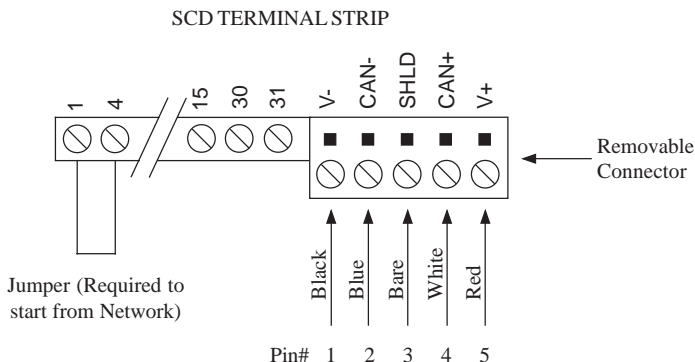

**NOTE 1:** Make sure the SCD drive is powered down and the network power supply is OFF before wiring to the connector.

**NOTE 2:** After wiring the connector, make sure the network power supply is ON before applying power to the drive. Applying power to the drive without the network power supply will cause the DeviceNet™ module to enter a non-recoverable fault: "DeviceNet Power Lost".

Once the wiring is complete and the network power supply is ON and SCD drive is powered up, program the address and network baud rate to the required values. Do this using the programming buttons on the front of the drive (refer to Section 13.0 - PROGRAMMING THE SCD DRIVE) to set the following parameters:

C00 - DEVICENET NODE ADDRESS	Range is 0 to 63 (default = 63)
C01 - DEVICENET BAUD RATE	0 = 125 kbps, 1 = 250 kbps, 2 = 500 kbps (default = 125)

Once these parameters are set, cycle power to the drive. This will make the address and baud rate parameters take effect. Also, during power-up (and resets), the SCD drive will perform the following functions:

1. Power up initializations; sets all variables and states.
2. Sets the MAC address and baud rate base on values programmed in EEPROM.
3. Checks for duplicate node address to verify that its own address is unique on the network.

If the power-up or reset sequence fails, the SCD drive will enter DeviceNet failure mode. In that case, the drive will not be accessible to the network, but can still be operated in terminal mode. This failure state is indicated in parameter C10 DIAGNOSTIC by number "093" (refer to Section B.6 and B.7 for details on parameter C10).

### **B.3 BASIC MODE OF OPERATION**

The SCD Series Drive can operate under DeviceNet™ control in any terminal configuration shown in Section 11.0 of this manual. The DeviceNet Master can take control any time by setting the Network Control bit (attribute 5 in Control Supervisor Object - see supported Objects and attributes on following pages).

#### **B.3.1 SAMPLE SETUP AND WIRING FOR DEVICENET™ CONTROL**

This example uses Explicit or I/O Polled messaging for Run Forward/Reverse and speed control.

**NOTE:** Terminal 1 must be closed to terminal 4 in order to start the drive through the DeviceNet™ interface.

#### **PARAMETER SET-UP:**

Parameters can be setup using the drive keypad, EPM Programmer, or DeviceNet™ configuration tool (for example RSNetWorx™) that uses EDS file provided by AC Technology.

The following parameters should be set as a minimum:

- P17 ROTATION DIRECTION - Set this parameter to FORWARD & REVERSE (02) if operation in both directions is required.
- P85 MOTOR NOMINAL SPEED AT RATED FREQUENCY (RPM)
- P86 MOTOR RATED CURRENT (0.1 A)
- P87 MOTOR RATED VOLTAGE (V)
- P88 MOTOR RATED FREQUENCY (Hz)
- P89 DRIVE RATED CURRENT (0.1 A)
- P90 DRIVE RATED VOLTAGE (V)
- C00 DEVICENET NODE ADDRESS (0 - 63)
- C01 DEVICENET BAUD RATE (125, 250, 500 kbps)
- C03 DEVICENET OUTPUT ASSEMBLY SELECTION - Set this parameter to select output assembly for Polled connection. The following selections are available:

- 1 = "1 Basic Contactor"
- 2 = "2 Basic Overload"
- 3 = "3 Basic Motor Starter"
- 4 = "4 Ext. Contactor"
- 5 = "5 Ext. Motor Starter"
- 6 = "20 Basic Speed Ctrl"
- 7 = "21 Ext. Speed Ctrl RPM"
- 8 = "100 Ext.Speed Ctrl Hz"
- 9 = "103 Preset Speed Ctrl"

The most versatile assemblies are #21 (selection 7) and #100 (selection 8). They allow RUN FORWARD and RUN REVERSE control as well as speed control. Refer to Section B.6 for more assembly details.

**C04 DEVICENET INPUT ASSEMBLY SELECTION** - Set this parameter for Polled, COS or Cyclic I/O connection. Refer to Section B.6 for more assembly details.

**NOTE:** If Parameter C00 - NETWORK ADDRESS or C01 - BAUD RATE have been changed, the drive must be reset by cycling power or by issuing a RESET command via the DeviceNet™ network before the new values take effect.

To simplify setup and assist in maintaining the DeviceNet™ network, the EDS file supporting the SCD Series drive is available from AC Technology. To obtain a copy of the appropriate EDS file, please contact AC Technology Corp, or visit the AC Tech website.

### B.3.2 SAMPLE OF SETUP AND TEST RUNS USING RSNETWORXTM FOR DEVICENET

1. Make all necessary DeviceNet™ network connections.
2. Using "EDS Hardware Installation Tool" register the EDS file for SCD family of drives.
3. Switch mode to ONLINE. After browsing through all available addresses on the network, "AC Tech SCD Drive" should appear at the programmed address.
4. To access the drive parameters double click on the drive icon.
5. After uploading parameters from the SCD drive, they can be edited and downloaded back to the drive. SCD drive parameters accessed through the drive keypad are mapped starting at location ID #41, to simplify programming they have a drive parameter number in front of their name.

For example: Parameter ID #42 corresponds to drive parameter "#2 Carrier Select"

Parameter ID #43 corresponds to drive parameter "#3 Start Method"

DeviceNet™ parameter IDs #1 to #40 are only accessible through the network connection.

To assist in Network Controlled test runs, the EDS file consists of parameters that permit triggering RUN commands by changing the parameter values.

**ID #20 - Control Source:** Must be set to NETWORK CONTROL before RUN FWD or RUN REV will be accepted. This parameter is mapped to Control Supervisor Object 0x29-1-5.

**ID #21 - Run Forward:** If terminals 1 and 4 are closed the drive will RUN FORWARD. This parameter is mapped to Control Supervisor Object 0x29-1-3.

**ID #22 - Run Reverse:** If terminals 1 and 4 are closed and Parameter #17 - ROTATION is set to FORWARD AND REVERSE, the drive will RUN REVERSE. This parameter is mapped to Control Supervisor Object 0x29-1-4.

**NOTE:** RUN and STOP commands must be triggered according to the table in Section B.5.9.

ID #25 - Speed Reference: To set the speed reference via the network, set this parameter to NETWORK REFERENCE. This parameter is mapped to AC/DC Drive Object 0x2A-1-4.

ID #26 - Network Reference Frequency: Controls the drive speed reference if parameter ID #25 is set to NETWORK REFERENCE. This parameter is mapped to Parameter Object 0x0F-26-1.

**WARNING!**

Make sure it is safe to operate the driven equipment prior to starting the SCD Series drive from the network. Damage to equipment and/or injury to personnel can result!

## **B.4 DEVICENET™ IMPLEMENTATION FOR THE SCD SERIES DRIVE**

The following describes the DeviceNet™ network protocol implementation on the SCD Series drive. The SCD Drive can be operated as a slave device on a DeviceNet™ network. It supports Explicit Messages and the following I/O messages of the predefined master/slave connection set:

- Polled
- Bit Strobe
- Changed of state
- Cyclic

**NOTE:** It does not support the Explicit Unconnected Message Manager!

To assist in verifying data integrity, attribute Configuration Consistency Value of the Identity Object has been implemented.

To simplify setup and operation, implemented classes and behavior conform to the AC DRIVE profile as specified in the ODVA DeviceNet™ standard.

To assist in recovery from Communication Faulted condition, Offline Connection Set messages are supported. The SCD supports the following Group 4 message types:

**Group 4 Message ID 2C - Communication Faulted Response Message**

**Group 4 Message ID 2D - Communication Faulted Request Message**

Using these messages, the user will be able to identify a faulted drive and when possible, re-establish communication without disconnecting the network or resetting the drive. After receiving "Identify Request Message" while in Communication Faulted state, the two upper decimal points on the drive's display will flash and the display will indicate "Idn".

The following baud rates are available: 125 kbps, 250 kbps, 500 kbps

The SCD drive supports the following object classes:

- |   |   |
|---|---|
| 1. Identity Object - Class 0x01             | 7. Parameter Group Object -Class 0x10       |
| 2. Message Router Object - Class 0x02       | 8. Motor Data Object - Class 0x28           |
| 3. DeviceNet Object - Class 0x03            | 9. Control Supervisor Object - Class 0x29   |
| 4. Assembly Object - Class 0x04             | 10. AC/DC Drive Object - Class 0x2A         |
| 5. DeviceNet Connection Object - Class 0x05 | 11. Acknowledge Handler Object - Class 0x2B |
| 6. Parameter Object - Class 0x0F            |   |

## B.5 CLASS IMPLEMENTATION DETAILS

### B.5.1 IDENTITY OBJECT - CLASS 0x01

IDENTITY CLASS ATTRIBUTES				
ATTRIBUTE ID	ACCESS RULE	NAME	DATA TYPE	VALUE
<b>INSTANCE 0</b>				
1	GET	REVISION	UINT	1
<b>INSTANCE 1</b>				
1	GET	VENDOR ID	UINT	587
2	GET	DEVICE TYPE	UINT	2 (AC drive)
3	GET	PRODUCT CODE	UINT	1 (SCD drive)
4	GET	MAJOR REV. MINOR REV.	USINT USINT	2 1
5	GET	STATUS	USINT	4 = Configured 5 = Owned
6	GET	SERIAL NUMBER	UDINT	Unique 32-bit number
7	GET	PRODUCT NAME	ASCII String	"AC Tech SCD Drive"
9	GET	CONFIG. CONSISTENCY	UINT	EEPROM Checksum

IDENTITY CLASS SERVICES			
SERVICE CODE	IMPLEMENTED FOR		SERVICE NAME
	CLASS	INSTANCE	
0x0E	YES	YES	Get_Attribute_Single
0x05	NO	YES	RESET

### B.5.2 MESSAGE ROUTER OBJECT - CLASS 0x02

MESSAGE ROUTER CLASS ATTRIBUTES				
ATTRIBUTE ID	ACCESS RULE	NAME	DATA TYPE	VALUE
<b>INSTANCE 0</b>				
1	GET	REVISION	UINT	1
<b>INSTANCE 1</b>				
1	GET	CLASS LIST	ARRAY	List of Implemented Classes
2	GET	MAXIMUM NUBER OF CONNECTIONS	UINT	1
3	GET	CURRENTLY USED CONNECTIONS	UINT	1
4	GET	CURRENTLY USED ID's	Array of UINT	List of Connection ID

<b>MESSAGE ROUTER CLASS SERVICES</b>			
SERVICE CODE	IMPLEMENTED FOR		SERVICE NAME
	CLASS	INSTANCE	
0x0E	YES	YES	Get_Attribute_Single

### B.5.3 DEVICENET OBJECT - CLASS 0x03

<b>DEVICENET CLASS ATTRIBUTES</b>				
ATTRIBUTE ID	ACCESS RULE	NAME	DATA TYPE	VALUE
<b>INSTANCE 0</b>				
1	GET	REVISION	UINT	2
<b>INSTANCE 1</b>				
1	GET	NODE ADDRESS	USINT	0 to 63
2	GET	DATA RATE	USINT	0 to 2
3	GET/SET	BOI	BOOL	0 = Hold in Error 1 = Reset CAN
4	GET/SET	BUS-OFF COUNTER	USINT	0 to 255
5	GET	ALLOCATION INFO ALLOC. CHOICE MASTER ADDRESS	BYTE USINT	Allocation Byte 0 to 63 Address

<b>DEVICENET CLASS SERVICES</b>			
SERVICE CODE	IMPLEMENTED FOR		SERVICE NAME
	CLASS	INSTANCE	
0x0E	YES	YES	Get_Attribute_Single
0x10	NO	YES	Set_Attribute_Single
0x4B	NO	YES	Allocate_Master/Slave_Connection_Set
0x4C	NO	YES	Release_Master/Slave_Connection_Set

**B.5.4 ASSEMBLY OBJECT - CLASS 0x04**

<b>ASSEMBLY CLASS ATTRIBUTES</b>				
ATTRIBUTE ID	ACCESS RULE	NAME	DATA TYPE	VALUE
<b>INSTANCE 0</b>				
1	GET	REVISION	UINT	2
2	GET	MAXIMUM NUMBER OF INSTANCES	USINT	20
<b>INSTANCES (See Below)</b>				
1	GET	NUMBER OF MEMBER	USINT	1
3	GET/SET	DATA	INSTANCE DEPENDENT	

<b>INSTANCE NUMBER AND NAME</b>	<b>ACCESS RULE FOR ATTRIBUTE #3 DATA</b>
INSTANCE 1 = BASIC CONTACTOR	GET / SET
INSTANCE 2 = BASIC OVERLOAD	GET / SET
INSTANCE 3 = BASIC MOTOR STARTER	GET / SET
INSTANCE 4 = EXTENDED CONTACTOR	GET / SET
INSTANCE 5 = EXTENDED MOTOR STARTER	GET / SET
INSTANCE 20 = BASIC SPEED CONTROL	GET / SET
INSTANCE 21 = EXT. SPEED CONTROL	GET / SET
INSTANCE 100 = EXT. SPEED CONTROL Hz	GET / SET
INSTANCE 103 = PRESET SPEED CONTROL	GET / SET
INSTANCE 50 = BASIC OVERLOAD	GET
INSTANCE 51 = EXTENDED OVERLOAD	GET
INSTANCE 52 = BASIC MOTOR CONTROL	GET
INSTANCE 53 = EXT. MOTOR CONTROL 1	GET
INSTANCE 54 = EXT. MOTOR CONTROL 2	GET
INSTANCE 70 = BASIC SPEED CONTROL	GET
INSTANCE 71 = EXT. SPEED CONTROL	GET
INSTANCE 101 = EXT. SPEED CONTROL Hz	GET
INSTANCE 102 = CUSTOM ASSEMBLY	GET
INSTANCE 104 = CUSTOM ASSEMBLY	GET
INSTANCE 105 = CUSTOM ASSEMBLY	GET

<b>ASSEMBLY CLASS SERVICES</b>			
SERVICE CODE	IMPLEMENTED FOR		SERVICE NAME
	CLASS	INSTANCE	
0x0E	YES	YES	Get_Attribute_Single
0x05	NO	YES	RESET

**B.5.5 DEVICENET CONNECTION OBJECT - CLASS 0x05**

<b>DEVICENET CONNECTION CLASS ATTRIBUTES</b>				
<b>ATTRIBUTE ID</b>	<b>ACCESS RULE</b>	<b>NAME</b>	<b>DATA TYPE</b>	<b>VALUE</b>
<b>INSTANCE 0</b>				
1	GET	REVISION	UINT	1
<b>INSTANCE 1 - EXPLICIT MESSAGE INSTANCE</b>				
1	GET	STATE	USINT	0 = Nonexistent 1 = Configuring 3 = Established 4 = Timed Out 5 = Deferred Delete
2	GET	INSTANCE TYPE	USINT	0 = Explicit
3	GET	TRANSPORT CLASS TRIGGER	USINT	0x83
4	GET	PRODUCED CONNECTION ID	UINT	
5	GET	CONSUMED CONNECTION ID	UINT	
6	GET	INITIAL COMM. CHARACTERISTICS	USINT	0x21
7	GET	PRODUCED CONNECTION SIZE	UINT	80 (max)
8	GET	CONSUMED CONNECTION SIZE	UINT	80 (max)
9	GET /SET	EXPECTED PACKET RATE	UINT	Timer Resolution of 2 ms
12	GET /SET	WATCHDOG ACTION	UINT	1 = Auto Delete 3 = Deferred Delete
13	GET	PRODUCED CONN. PATH LENGTH	UINT	0
14	GET	PRODUCED CONNECTION PATH		Null (No Data)
15	GET	CONSUMED CONN. PATH LENGTH	UINT	0
16	GET	CONSUMED CONNECTION PATH		Null (No Data)
17	GET	INHIBIT TIME	USINT	0

<b>DEVICENET CONNECTION CLASS ATTRIBUTES</b>				
<b>ATTRIBUTE ID</b>	<b>ACCESS RULE</b>	<b>NAME</b>	<b>DATA TYPE</b>	<b>VALUE</b>
<b>INSTANCE 2 - POLLED I/O MESSAGE CONNECTION</b>				
1	GET	STATE	USINT	0 = Nonexistent 1 = Configuring 3 = Established 4 = Timed Out
2	GET	INSTANCE TYPE	USINT	1 = I/O Connection
3	GET	TRANSPORT CLASS TRIGGER	USINT	0x82
4	GET	PRODUCED CONNECTION ID	UINT	
5	GET	CONSUMED CONNECTION ID	UINT	
6	GET	INITIAL COMM. CHARACTERISTICS	USINT	0x01
7	GET	PRODUCED CONNECTION SIZE	UINT	0 to 8
8	GET	CONSUMED CONNECTION SIZE	UINT	0 to 4
9	GET / SET	EXPECTED PACKET RATE	UINT	Timer Resolution of 2 ms
12	GET / SET	WATCHDOG ACTION	UINT	0 = Time Out 1 = Auto Delete 2 = Auto Reset
13	GET	PRODUCED CONN. PATH LENGTH	UINT	3
14	GET	PRODUCED CONNECTION PATH		0x63 (Hex String) Hex String - Assembly #
15	GET	CONSUMED CONN. PATH LENGTH	UINT	3
16	GET	CONSUMED CONNECTION PATH		0x63 (Hex String) Hex String - Assembly #
17	GET	INHIBIT TIME	USINT	0

## DEVICENET CONNECTION CLASS ATTRIBUTES

ATTRIBUTE ID	ACCESS RULE	NAME	DATA TYPE	VALUE
<b>INSTANCE 3 - BIT STROBE</b>				
1	GET	STATE	USINT	0 = Nonexistent 1 = Configuring 3 = Established 4 = Timed Out
2	GET	INSTANCE TYPE	USINT	1 = I/O Connection
3	GET	TRANSPORT CLASS TRIGGER	USINT	0x82
4	GET	PRODUCED CONNECTION ID	UINT	
5	GET	CONSUMED CONNECTION ID	UINT	
6	GET	INITIAL COMM. CHARACTERISTICS	USINT	0x02
7	GET	PRODUCED CONNECTION SIZE	UINT	0 to 8
8	GET	CONSUMED CONNECTION SIZE	UINT	8
9	GET / SET	EXPECTED PACKET RATE	UINT	Timer Resolution of 2 ms
12	GET / SET	WATCHDOG ACTION	UINT	0 = Time Out 1 = Auto Delete 2 = Auto Reset
13	GET	PRODUCED CONN. PATH LENGTH	UINT	3
14	GET	PRODUCED CONNECTION PATH		0x63 (Hex String) Hex String - Assembly #
15	GET	CONSUMED CONN. PATH LENGTH	UINT	3
16	GET	CONSUMED CONNECTION PATH		0x63 (Hex String) Hex String - Assembly #
17	GET	INHIBIT TIME	USINT	0

<b>DEVICENET CONNECTION CLASS ATTRIBUTES</b>				
<b>ATTRIBUTE ID</b>	<b>ACCESS RULE</b>	<b>NAME</b>	<b>DATA TYPE</b>	<b>VALUE</b>
<b>INSTANCE 4 - CHANGE OF STATE / CYCLIC INSTANCE</b>				
1	GET	STATE	USINT	0 = Nonexistent 1 = Configuring 3 = Established 4 = Timed Out
2	GET	INSTANCE TYPE	USINT	1 = I/O Connection
3	GET	TRANSPORT CLASS TRIGGER	USINT	0x00 or 0x02 for Cyclic 0x10 or 0x12 for COS
4	GET	PRODUCED CONNECTION ID	UINT	
5	GET	CONSUMED CONNECTION ID	UINT	
6	GET	INITIAL COMM. CHARACTERISTICS	USINT	0x01 or 0x0F
7	GET	PRODUCED CONNECTION SIZE	UINT	0 to 8
8	GET	CONSUMED CONNECTION SIZE	UINT	0
9	GET / SET	EXPECTED PACKET RATE	UINT	Timer Resolution of 2 ms
12	GET / SET	WATCHDOG ACTION	UINT	0 = Time Out 1 = Auto Delete 2 = Auto Reset
13	GET	PRODUCED CONN. PATH LENGTH	UINT	3
14	GET	PRODUCED CONNECTION PATH		0x63 (Hex String) Hex String - Assembly #
15	GET	CONSUMED CONN. PATH LENGTH	UINT	3
16	GET	CONSUMED CONNECTION PATH		0x63 (Hex String) Hex String - Assembly #
17	GET / SET	INHIBIT TIME	USINT	0

### DEVICENET CONNECTION CLASS SERVICES

SERVICE CODE	IMPLEMENTED FOR		SERVICE NAME
	CLASS	INSTANCE	
0x0E	YES	YES	Get_Attribute_Single
0x10	NO	YES	Set_Attribute_Single

#### B.5.6 PARAMETER OBJECT - CLASS 0x0F

### PARAMETER CLASS ATTRIBUTES

NUMBER OF INSTANCES (PARAMETERS): 150

ATTRIBUTE ID	ACCESS RULE	NAME	DATA TYPE	VALUE
<b>INSTANCE 0</b>				
1	GET	REVISION	UINT	2
2	GET	NO. OF INSTANCES	UINT	150
8	GET	PARAMETER CLASS DESCRIPTOR	WORD	0x03
9	GET	CONFIGURATION ASSEMBLY #	UINT	0
10	GET	NATIVE LANGUAGE	UINT	0 = English
<b>INSTANCE 1 - 150</b>				
1	GET / SET	PARAMETER VALUE		
2	GET	LINK PATH SIZE	USINT	0 to 2
3	GET	LINK PATH	DNET PATH	
4	GET	DESCRIPTOR	WORD	
5	GET	DATA TYPE	USINT	
6	GET	DATA SIZE	USINT	

**NOTE:** See next page for Parameter List

### PARAMETER CLASS SERVICES

SERVICE CODE	IMPLEMENTED FOR		SERVICE NAME
	CLASS	INSTANCE	
0x0E	YES	YES	Get_Attribute_Single
0x10	NO	YES	Set_Attribute_Single

**PARAMETER OBJECT INSTANCE (PARAMETER LIST)**

NOTE: THE SAME PARAMETERS ARE PRESENT IN THE EDS FILE

ID NO.	PARAMETER	OBJECT MAPPING
1	OUTPUT FREQUENCY (0.1 Hz)	0x0F-1-1
2	OUTPUT VOLTAGE (V)	0x2A-1-17
3	OUTPUT CURRENT (100mA)	0x2A-1-9
4	OUTPUT POWER (W)	0x2A-1-15
5	INPUT VOLTAGE (V)	0x2A-1-16
6	COMMANDED FREQUENCY (0.1 Hz)	0x0F-6-1
7	PRESENT FAULT DNET CODE	0x29-1-13
8	PRESENT FAULT NAME	0x0F-8-1
9- 16	RESERVED	
17	BUS OFF ERROR	0x03-1-3
18	BUS OFF COUNT	0x03-1-4
19	DEVICENET IDLE MODE	0x0F-19-1
20	CONTROL SOURCE	0x29-1-5
21	RUN FORWARD	0x29-1-3
22	RUN REVERSE	0x29-1-4
23	FAULT RESET	0x29-1-12
24	DEVICENET PRESET COMMAND	0x0F-24-1
25	SPEED REFERENCE	0x2A-1-4
26	NETWORK REFERENCE FREQUENCY	0x0F-26-1
27	STATUS OF RUN/STOP CONTROL SRC	0x29-1-15
28	STATUS OF SPEED REFERENCE	0x2A-1-29
29	ACTUAL DIRECTION	0x0F-29-1
30	RUN STATE	0x0F-30-1
31	SPEED SOURCE	0x0F-31-1
32	RESERVED	
33	AT REFERENCE STATUS	0x2A-1-3
34	RESERVED	
35	COS STATUS	0x0F-35-1
36	COS MASK	0x0F-36-1
37	RESERVED	
38	KEYPAD COMMAND FREQUENCY	0x0F-38-1
39	RESERVED	
40	ACT EEPROM VERSION - PARAMETER VERSION ID NUMBER	0x0F-40-1

ID NO.	PARAMETER	OBJECT MAPPING
41	ACT PARAMETER 1 LINE VOLTAGE	0x0F-41-1
42	ACT PARAMETER 2 CARRIER	0x0F-42-1
43	ACT PARAMETER 3 START	0x0F-43-1
44	ACT PARAMETER 4 STOP	0x0F-44-1
45	ACT PARAMETER 5 STANDARD SPEED SOURCE	0x0F-45-1
46	ACT PARAMETER 6 TB14 OUTPUT FUNCTION	0x0F-46-1
47	ACT RESERVED 7 TORQUE SELECTION	0x0F-47-1
48	ACT PARAMETER 8 TB30 OUTPUT FUNCTION	0x0F-48-1
49	ACT PARAMETER 9 TB31 OUTPUT FUNCTION	0x0F-49-1
50	ACT PARAMETER 10 TB13A INPUT FUNCTION	0x0F-50-1
51	ACT PARAMETER 11 TB13B INPUT FUNCTION	0x0F-51-1
52	ACT PARAMETER 12 TB13C INPUT FUNCTION	0x0F-52-1
53	ACT PARAMETER 13 TB15 OUTPUT FUNCTION	0x0F-53-1
54	ACT PARAMETER 14 CONTROL	0x0F-54-1
55	ACT RESERVED 15	
56	ACT PARAMETER 16 UNITS EDITING	0x0F-56-1
57	ACT PARAMETER 17 AVAILABLE DIRECTION	0x0F-57-1
58	ACT RESERVED 18	
59	ACT PARAMETER 19 ACCELERATION TIME	0x0F-59-1
60	ACT PARAMETER 20 DECELERATION TIME	0x0F-60-1
61	ACT PARAMETER 21 DC BRAKE TIME	0x0F-61-1
62	ACT PARAMETER 22 DC BRAKE VOLTS	0x0F-62-1
63	ACT PARAMETER 23 MINIMUM FREQUENCY	0x0F-63-1
64	ACT PARAMETER 24 MAXIMUM FREQUENCY	0x0F-64-1
65	ACT PARAMETER 25 CURRENT LIMIT	0x0F-65-1
66	ACT PARAMETER 26 MOTOR OVERLOAD	0x0F-66-1
67	ACT PARAMETER 27 BASE FREQUENCY	0x0F-67-1
68	ACT PARAMETER 28 FIXED BOOST	0x0F-68-1
69	ACT PARAMETER 29 ACCEL BOOST	0x0F-69-1
70	ACT PARAMETER 30 SLIP COMPENSATION	0x0F-70-1
71	ACT PARAMETER 31 PRESET SPEED #1	0x0F-71-1
72	ACT PARAMETER 32 PRESET SPEED #2	0x0F-72-1
73	ACT PARAMETER 33 PRESET SPEED #3	0x0F-73-1
74	ACT PARAMETER 34 PRESET SPEED #4	0x0F-74-1
75	ACT PARAMETER 35 PRESET SPEED #5	0x0F-75-1
76	ACT PARAMETER 36 PRESET SPEED #6	0x0F-76-1
77	ACT PARAMETER 37 PRESET SPEED #7	0x0F-77-1
78	ACT PARAMETER 38 SKIP BANDWIDTH	0x0F-78-1
79	ACT PARAMETER 39 SPEED SCALING	0x0F-79-1

ID NO.	PARAMETER		OBJECT MAPPING
80	ACT PARAMETER	40 TB30 MAX SCALING	0x0F-80-1
81	ACT RESERVED	41 TB31 MAX SCALING	0x0F-81-1
82	ACT PARAMETER	42 SECOND ACCEL/DECEL TIME	0x0F-82-1
83	ACT RESERVED	43	
84	ACT PARAMETER	44 PASSWORD	0x0F-84-1
85 - 86	ACT RESERVED	45 - 46	
87	ACT PARAMETER	47 CLEAR FAULT HISTORY	0x0F-87-1
88	ACT PARAMETER	48 FACTORY PARAMETERS	0x0F-88-1
89	ACT RESERVED	49	
90	ACT PARAMETER	50 READ ONLY: FAULT HISTORY	0x0F-90-1
91	ACT PARAMETER	51 READ ONLY: SW VERSION	0x0F-91-1
92	ACT PARAMETER	52 READ ONLY: BUS VOLTAGE	0x0F-92-1
93	ACT RESERVED	53 READ ONLY: MOTOR VOLTAGE	0x0F-93-1
94	ACT PARAMETER	54 READ ONLY: BUS CURRENT	0x0F-94-1
95	ACT PARAMETER	55 READ ONLY: 0-10 VDC ANALOG INPUT	0x0F-95-1
96	ACT PARAMETER	56 READ ONLY: 4-20 MA ANALOG INPUT	0x0F-96-1
97	ACT PARAMETER	57 READ ONLY: DIGITAL INPUT	0x0F-97-1
98	ACT PARAMETER	58 READ ONLY: DIGITAL OUTPUT	0x0F-98-1
99	ACT PARAMETER	59 READ ONLY: ANALOG OUTPUT TB30	0x0F-99-1
100	ACT PARAMETER	60 READ ONLY: ANALOG OUTPUT TB31	0x0F-100-1
101 - 124	ACT RESERVED	61 - 84	
125	ACT PARAMETER	85 MOTOR SPEED AT RATED FREQ	0x28-1-15
126	ACT PARAMETER	86 MOTOR RATED CURRENT	0x28-1-6
127	ACT PARAMETER	87 MOTOR RATED VOLTAGE	0x28-1-7
128	ACT PARAMETER	88 MOTOR RATED FREQUENCY	0x28-1-9
129	ACT PARAMETER	89 DRIVE RATED CURRENT	0x0F-129-1
130	ACT PARAMETER	90 DRIVE RATED VOLTAGE	0x0F-130-1
131 - 139	ACT RESERVED	91 - 99	
140	ACT PARAMETER	C00 DEVICENET NODE ADDRESS	0x0F-140-1
141	ACT PARAMETER	C01 DEVICENET BAUD RATE	0x0F-141-1
142	ACT PARAMETER	C02 ACTION ON LOSS OF DEVICENET	0x29-1-16
143	ACT PARAMETER	C03 DNET OUTPUT ASSEMBLY SELECT.	0x0F-143-1
144	ACT PARAMETER	C04 DNET INPUT ASSEMBLY SELECTION	0x0F-144-1
145	ACT PARAMETER	C05 DNET CUSTOM INPUT ASSEMBLY 0	0x0F-145-1
146	ACT PARAMETER	C06 DNET CUSTOM INPUT ASSEMBLY 1	0x0F-146-1
147	ACT PARAMETER	C07 DNET CUSTOM INPUT ASSEMBLY 2	0x0F-147-1
148	ACT PARAMETER	C08 DNET CUSTOM INPUT ASSEMBLY 3	0x0F-148-1
149	ACT PARAMETER	C09 DEVICENET MOTOR TYPE	0x28-1-3
150	ACT PARAMETER	C10 DEVICENET DIAGNOSTICS	0x0F-150-1

**B.5.7 PARAMETER GROUP OBJECT - CLASS 0x10**

<b>PARAMETER GROUP CLASS ATTRIBUTES</b>				
ATTRIBUTE ID	ACCESS RULE	NAME	DATA TYPE	VALUE
<b>INSTANCE 0</b>				
1	GET	REVISION	UINT	1
2	GET	NUMBER OF INSTANCES	UINT	4
8	GET	NATIVE LANGUAGE	UINT	0 = English
<b>INSTANCE 1 - 3</b>				
1	GET	GROUP NAME	SHORT STRING	
2	GET	NUMBER OF MEMBERS IN THE GROUP	UINT	
3	GET	1st PARAMETER IN THE GROUP	UINT	
4	GET	2nd PARAMETER IN THE GROUP	UINT	
n	GET	(n-2) th PARAMETER IN THE GROUP	UINT	

The SCD parameters that are accessible through the network are separated into 4 groups: Monitor and Control, Program, DNET Config, and Motor Data. The same groups are implemented in the EDS file.

**IMPLEMENTED PARAMETER GROUPS:**

<b>GROUP 1 - INSTANCE 1</b>			
<b>NAME: "MONITOR AND CONTROL"</b>			
ID	PARAMETER	ID	PARAMETER
1	OUTPUT FREQUENCY (0.1 Hz)	30	RUN STATE
2	OUTPUT VOLTAGE (V)	31	SPEED SOURCE
3	OUTPUT CURRENT (100mA)	33	AT REFERENCE STATUS
4	OUTPUT POWER (W)	20	CONTROL SOURCE
5	INPUT VOLTAGE (V)	21	RUN FORWARD
6	COMMANDED FREQUENCY (0.1 Hz)	22	RUN REVERSE
7	PRESENT FAULT DNET CODE	23	FAULT RESET
8	PRESENT FAULT NAME	24	DEVICENET PRESET COMMAND
27	STATUS OF RUN/STOP CONTROL SRC	25	SPEED REFERENCE
28	STATUS OF SPEED REFERENCE	26	NETWORK REFERENCE FREQUENCY
29	ACTUAL DIRECTION	38	KEYPAD COMMAND FREQUENCY

**GROUP 2 - INSTANCE 2****NAME: "PROGRAM"**

ID NO.	PARAMETER
40	ACT EEPROM VERSION - PARAMETER VERSION IDENTIFICATION NUMBER
41	ACT PARAMETER 1 LINE VOLTAGE
42	ACT PARAMETER 2 CARRIER
43	ACT PARAMETER 3 START
44	ACT PARAMETER 4 STOP
45	ACT PARAMETER 5 STANDARD SPEED SOURCE
46	ACT PARAMETER 6 TB14 OUTPUT FUNCTION
47	ACT RESERVED 7 TORQUE SELECTION
48	ACT PARAMETER 8 TB30 OUTPUT FUNCTION
49	ACT PARAMETER 9 TB31 OUTPUT FUNCTION
50	ACT PARAMETER 10 TB13A INPUT FUNCTION
51	ACT PARAMETER 11 TB13B INPUT FUNCTION
52	ACT PARAMETER 12 TB13C INPUT FUNCTION
53	ACT PARAMETER 13 TB15 OUTPUT FUNCTION
54	ACT PARAMETER 14 CONTROL
55	ACT RESERVED 15
56	ACT PARAMETER 16 UNITS EDITING
57	ACT PARAMETER 17 AVAILABLE DIRECTION
58	ACT RESERVED 18
59	ACT PARAMETER 19 ACCELERATION TIME
60	ACT PARAMETER 20 DECELERATION TIME
61	ACT PARAMETER 21 DC BRAKE TIME
62	ACT PARAMETER 22 DC BRAKE VOLTS
63	ACT PARAMETER 23 MINIMUM FREQUENCY
64	ACT PARAMETER 24 MAXIMUM FREQUENCY
65	ACT PARAMETER 25 CURRENT LIMIT
66	ACT PARAMETER 26 MOTOR OVERLOAD
67	ACT PARAMETER 27 BASE FREQUENCY
68	ACT PARAMETER 28 FIXED BOOST
69	ACT PARAMETER 29 ACCEL BOOST
70	ACT PARAMETER 30 SLIP COMPENSATION
71	ACT PARAMETER 31 PRESET SPEED #1
72	ACT PARAMETER 32 PRESET SPEED #2
73	ACT PARAMETER 33 PRESET SPEED #3
74	ACT PARAMETER 34 PRESET SPEED #4
75	ACT PARAMETER 35 PRESET SPEED #5
76	ACT PARAMETER 36 PRESET SPEED #6
77	ACT PARAMETER 37 PRESET SPEED #7
78	ACT PARAMETER 38 SKIP BANDWIDTH
79	ACT PARAMETER 39 SPEED SCALING

ID NO.	PARAMETER	
80	ACT PARAMETER	40 TB30 MAX SCALING
81	ACT RESERVED	41 TB31 MAX SCALING
82	ACT PARAMETER	42 SECOND ACCEL/DECEL TIME
83	ACT RESERVED	43
84	ACT PARAMETER	44 PASSWORD
85 - 86	ACT RESERVED	45 - 46
87	ACT PARAMETER	47 CLEAR FAULT HISTORY
88	ACT PARAMETER	48 FACTORY PARAMETERS
89	ACT RESERVED	49
90	ACT PARAMETER	50 READ ONLY: FAULT HISTORY
91	ACT PARAMETER	51 READ ONLY: S/W VERSION
92	ACT PARAMETER	52 READ ONLY: BUS VOLTAGE
93	ACT RESERVED	53 READ ONLY: MOTOR VOLTAGE
94	ACT PARAMETER	54 READ ONLY: BUS CURRENT
95	ACT PARAMETER	55 READ ONLY: 0-10 VDC ANALOG INPUT
96	ACT PARAMETER	56 READ ONLY: 4-20 MA ANALOG INPUT
97	ACT PARAMETER	57 READ ONLY: DIGITAL INPUT
98	ACT PARAMETER	58 READ ONLY: DIGITAL OUTPUT
99	ACT PARAMETER	59 READ ONLY: ANALOG OUTPUT TB30
100	ACT PARAMETER	60 READ ONLY: ANALOG OUTPUT TB31
101 - 124	ACT RESERVED	61 - 84
125	ACT PARAMETER	85 MOTOR NOMINAL SPEED AT RATED FREQUENCY
126	ACT PARAMETER	86 MOTOR RATED CURRENT
127	ACT PARAMETER	87 MOTOR RATED VOLTAGE
128	ACT PARAMETER	88 MOTOR RATED FREQUENCY
129	ACT PARAMETER	89 DRIVE RATED CURRENT
130	ACT PARAMETER	90 DRIVE RATED VOLTAGE
131 - 139	ACT RESERVED	91 - 99
140	ACT PARAMETER	C00 DEVICENET NODE ADDRESS
141	ACT PARAMETER	C01 DEVICENET BAUD RATE
142	ACT PARAMETER	C02 ACTION ON LOSS OF DEVICENET
143	ACT PARAMETER	C03 DEVICENET OUTPUT ASSEMBLY SELECTION
144	ACT PARAMETER	C04 DEVICENET INPUT ASSEMBLY SELECTION
145	ACT PARAMETER	C05 DEVICENET CUSTOM INPUT ASSEMBLY WORD 0
146	ACT PARAMETER	C06 DEVICENET CUSTOM INPUT ASSEMBLY WORD 1
147	ACT PARAMETER	C07 DEVICENET CUSTOM INPUT ASSEMBLY WORD 2
148	ACT PARAMETER	C08 DEVICENET CUSTOM INPUT ASSEMBLY WORD 3
149	ACT PARAMETER	C09 DEVICENET MOTOR TYPE
150	ACT PARAMETER	C10 DEVICENET DIAGNOSTICS

**GROUP 3 - INSTANCE 3****NAME: "DNET CONFIG"**

ID NO.	PARAMETER
140	ACT PARAMETER C00 DEVICENET NODE ADDRESS
141	ACT PARAMETER C01 DEVICENET BAUD RATE
142	ACT PARAMETER C02 ACTION ON LOSS OF DEVICENET
143	ACT PARAMETER C03 DEVICENET OUTPUT ASSEMBLY SELECTION
144	ACT PARAMETER C04 DEVICENET INPUT ASSEMBLY SELECTION
145	ACT PARAMETER C05 DEVICENET CUSTOM INPUT ASSEMBLY WORD 0
146	ACT PARAMETER C06 DEVICENET CUSTOM INPUT ASSEMBLY WORD 1
147	ACT PARAMETER C07 DEVICENET CUSTOM INPUT ASSEMBLY WORD 2
148	ACT PARAMETER C08 DEVICENET CUSTOM INPUT ASSEMBLY WORD 3
149	ACT PARAMETER C09 DEVICENET MOTOR TYPE
150	ACT PARAMETER C10 DEVICENET DIAGNOSTICS
125	ACT PARAMETER 85 MOTOR NOMINAL SPEED AT RATED FREQUENCY
126	ACT PARAMETER 86 MOTOR RATED CURRENT
127	ACT PARAMETER 87 MOTOR RATED VOLTAGE
128	ACT PARAMETER 88 MOTOR RATED FREQUENCY
129	ACT PARAMETER 89 DRIVE RATED CURRENT
130	ACT PARAMETER 90 DRIVE RATED VOLTAGE
17	DEVICENET BUS OFF ERROR
18	DEVICENET BUS OFF COUNT
19	DEVICENET IDLE MODE
35	COS STATUS
36	COS MASK

**PARAMETER GROUP CLASS SERVICES**

SERVICE CODE	IMPLEMENTED FOR		SERVICE NAME
	CLASS	INSTANCE	
0x0E	YES	YES	Get_Attribute_Single
0x01	YES	YES	Get_Attribute_All

### B.5.8 MOTOR DATA OBJECT - CLASS 0x28

MOTOR DATA CLASS ATTRIBUTES				
ATTRIBUTE ID	ACCESS RULE	NAME	DATA TYPE	VALUE
<b>INSTANCE 0</b>				
1	GET	REVISION	UINT	1
2	GET	NUMBER OF INSTANCES	UINT	1
<b>INSTANCE 1</b>				
1	GET	NO. OF SUPPORTED ATTRIBUTES	USINT	7
2	GET	ATTRIBUTE LIST	ARRAY	
3	GET / SET	MOTOR TYPE	USINT	0 - 10
6	GET / SET	RATED CURRENT	UINT	RATED STATOR CURRENT (0.1 A)
7	GET / SET	RATED VOLTAGE	UINT	RATED BASE VOLTAGE (V)
9	GET / SET	RATED FREQUENCY	UINT	RATED FREQUENCY (Hz)
15	GET / SET	NOMINAL SPEED AT RATED FREQUENCY	UINT	NOMINAL SPEED (RPM)

MOTOR DATA CLASS SERVICES			
SERVICE CODE	IMPLEMENTED FOR		SERVICE NAME
	CLASS	INSTANCE	
0x0E	YES	YES	Get_Attribute_Single
0x10	NO	YES	Set_Attribute_Single

### B.5.9 CONTOL SUPERVISOR OBJECT - CLASS 0x29

CONTROL SUPERVISOR CLASS ATTRIBUTES				
ATTRIBUTE ID	ACCESS RULE	NAME	DATA TYPE	VALUE
<b>INSTANCE 0</b>				
1	GET	REVISION	UINT	1
2	GET	NUMBER OF INSTANCES	UINT	1

CONTROL SUPERVISOR CLASS ATTRIBUTES				
ATTRIBUTE ID	ACCESS RULE	NAME	DATA TYPE	VALUE
<b>INSTANCE 1</b>				
1	GET	NO. OF SUPPORTED ATTRIBUTES	USINT	16
2	GET	ATTRIBUTE LIST	ARRAY	
3	GET / SET	RUNFWD	BOOL	0 to 1
4	GET / SET	RUNREV	BOOL	0 to 1
5	GET / SET	NETCTRL	BOOL	0 to 1
6	GET	STATE	UINT	3 = Ready 4 = Enabled 7 = Faulted
7	GET	RUNNINGFWD	BOOL	0 to 1
8	GET	RUNNINGREV	BOOL	0 to 1
9	GET	READY	BOOL	0 to 1
10	GET	FAULTED	BOOL	0 to 1
11	GET	WARNING	UINT	0 (Not Supported)
12	GET / SET	FAULTRST	BOOL	0 to 1
13	GET	FAULT CODE	UINT	0 to 65535
15	GET	CTRLFROMNET	USINT	0 to 1
16	GET / SET	ACTION ON LOSS OF DEVICENET	USINT	0 = Fault 1 = Ignore Comm. Fault 2 = AC Tech Specific
17	GET / SET	FORCE TRIP	BOOL	0 to 1

The drive shows the "nF" fault on the LED display

If Attribute #5 NET CONTROL is set to 1, the RUN and STOP events are triggered according to the following event table:

ATTRIBUTE RUN FWD	ATTRIBUTE RUN REV	TRIGGER EVENT	RUN TYPE
0	0	STOP	N/A
0-->1	0	RUN	RUN FORWARD
0	0-->1	RUN	RUN REVERSE
0-->1	0-->1	NO ACTION	N/A
1	1	NO ACTION	N/A
1-->0	1	RUN	RUN REVERSE
1	1-->0	RUN	RUN FORWARD

**NOTE:** If ACT PARAMETER #17 DIRECTION is set to FORWARD ONLY, the drive will not be able to run in the reverse direction.

Fault Codes used in Attribute #13 FAULT CODE:

FAULT CODE	FAULT DESCRIPTION
0x0000	NO FAULT
0x2220	"OF" OUTPUT FAULT (OVERCURRENT)
0x4310	"AF" HIGH TEMPERATURE (OVER TEMPERATURE)
0x3210	"HF" HIGH BUS VOLTAGE (OVER VOLTAGE)
0x3220	"LF" LOW BUS VOLTAGE (UNDER VOLTAGE)
0x7122	"PF" OVERLOAD (MOTOR OVERLOAD)
0x6310	"CF" CONTROL FAULT (EEPROM FAULT)
0x9000	"EF" EXTERNAL (EXTERNAL FAULT)
0x6320	"GF" OEM DEFAULTS CORRUPTED (PARAMETER ERROR)
0x3120	"UF" START ERROR (POWER LOSS)
0x6100	"F1" INTERNAL 1 (EEPROM FAILURE)
0x6100	"F2" INTERNAL 2
0x6100	"F3" INTERNAL 3
0x6100	"F4" INTERNAL 4
0x6100	"F5" INTERNAL 5
0x6100	"F6" INTERNAL 6
0x6010	"F7" INTERNAL 7
0x6100	"F8" INTERNAL 8
0x6100	"F9" INTERNAL 9
0x6100	"Fo" INTERNAL 10
0x3130	"SF" VOLTAGE RIPPLE TOO HIGH - SINGLE PHASE SUPPLY (PHASE FAILURE)
0x6320	"cF" INCOMPATIBILITY FAULT (PARAMETER ERROR)
0x4200	"dF" DYNAMIC BRAKE OVERLOAD (DYNAMIC BRAKE OVERHEATED)
0x7503	"JF" COMMUNICATION LOST (DEVICENET TRANSMIT FAULT)
0x9000	"nF" DEVICENET TRIGGERED FAULT
0x6100	" F" UNUSED

<b>CONTROL SUPERVISOR CLASS SERVICES</b>			
SERVICE CODE	IMPLEMENTED FOR		SERVICE NAME
	CLASS	INSTANCE	
0x0E	YES	YES	Get_Attribute_Single
0x10	NO	YES	Set_Attribute_Single

### B.5.10 AC / DC DRIVE OBJECT - CLASS 0x2A

<b>AC / DC DRIVE CLASS ATTRIBUTES</b>				
ATTRIBUTE ID	ACCESS RULE	NAME	DATA TYPE	VALUE
<b>INSTANCE 0</b>				
1	GET	REVISION	UINT	1
2	GET	NUMBER OF INSTANCES	UINT	1
<b>INSTANCE 1</b>				
1	GET	NO. OF SUPPORTED ATTRIBUTES	USINT	12
2	GET	ATTRIBUTE LIST	ARRAY	
3	GET	AT REFERENCE	BOOL	Speed At Ref
4	GET / SET	NET REFERENCE	BOOL	0 = Local Spd Ref 1 = Net Spd Ref
6	GET	DRIVE MODE	USINT	1=Open Loop Spd Control
7	GET	ACTUAL SPEED	INT	Actual Speed (RPM)
8	GET / SET	SPEED REFERENCE	INT	Speed Reference (RPM)
9	GET	MOTOR PHASE CURRENT	INT	Actual Current (0.1 A)
15	GET	ACTUAL OUTPUT POWER	INT	Actual Power (W)
16	GET	INPUT VOLTAGE	INT	(V)
17	GET	OUTPUT VOLTAGE	INT	(V)
29	GET	STATUS OF SPEED REFERENCE	INT	0 = Local Spd Ref 1 = Net Spd Ref

<b>AC DRIVE CLASS SERVICES</b>			
SERVICE CODE	IMPLEMENTED FOR		SERVICE NAME
	CLASS	INSTANCE	
0x0E	YES	YES	Get_Attribute_Single
0x10	NO	YES	Set_Attribute_Single

### B.5.11 ACKNOWLEDGE HANDLER OBJECT - CLASS 0x2B

ACKNOWLEDGE HANDLER CLASS ATTRIBUTES				
ATTRIBUTE ID	ACCESS RULE	NAME	DATA TYPE	VALUE
<b>INSTANCE 0</b>				
1	GET	REVISION	UINT	1
2	GET	NUMBER OF INSTANCES	UINT	1
<b>INSTANCE 1</b>				
1	GET /SET	ACKNOWLEDGE TIMER	UINT	1 to 65535 ms
2	GET /SET	RETRY LIMIT	USINT	0 to 255
3	GET	COS PRODUCING CONN. INSTANCE	UINT	4

ACKNOWLEDGE HANDLER SERVICES			
SERVICE CODE	IMPLEMENTED FOR		SERVICE NAME
	CLASS	INSTANCE	
0x0E	YES	YES	Get_Attribute_Single
0x10	NO	YES	Set_Attribute_Single

### B.6 DESCRIPTION OF DEVICENET™ PARAMETERS

Parameter ID 40 to 130 (AC Tech parameters 1 to 90) have been described in detail in Section 15.0 - DESCRIPTION OF PARAMETERS.

**DNET Par. ID 1 - OUTPUT FREQUENCY (READ ONLY):** Actual output frequency to motor (0.1 Hz resolution).

**DNET Par. ID 2 - OUTPUT VOLTAGE (READ ONLY):** Actual output voltage to the motor (1 Volt resolution).

**DNET Par. ID 3 - OUTPUT CURRENT (READ ONLY):** Output current to the motor (0.1 Amp resolution).

**DNET Par. ID 4 - ESTIMATED OUTPUT POWER (READ ONLY):** In Watts (1 Watt resolution).

**DNET Par. ID 5 - INPUT VOLTAGE (READ ONLY):** In Volts (1 Volt resolution).

**NOTE:** DNET Parameters 2, 3, 4, and 5 are estimated and their accuracy depends on the accuracy of the following parameters:

DNET ID 126 ACT Par 86 MOTOR RATED CURRENT  
 DNET ID 127 ACT Par 87 MOTOR RATED VOLTAGE  
 DNET ID 128 ACT Par 88 MOTOR RATED FREQUENCY  
 DNET ID 129 ACT Par 89 DRIVE RATED CURRENT  
 DNET ID 130 ACT Par 90 DRIVE RATED VOLTAGE

**DNET Par. ID 6 - COMMANDED FREQUENCY (READ ONLY):** Actual commanded frequency (speed) of the drive (0.1 Hz resolution).

**DNET Par. ID 7 - PRESENT FAULT DNET CODE (READ ONLY):** Shows the current fault code. Refer to the table in Section B.5.9.

**DNET Par. ID 8 - PRESENT FAULT NAME (READ ONLY):** See the table below:

PRESENT FAULT NAME					
NO.	FAULT NAME	NO.	FAULT NAME	NO.	FAULT NAME
0	NO FAULT	10	INTERNAL 1 EPM	20	SINGLE PHASE INPUT
1	OUTPUT FAULT	11	INTERNAL 2	21	INCOMPATIBLE EPM
2	HIGH TEMP.	12	INTERNAL 3	22	DYNAMIC BRAKE
3	HIGH BUS VOLTAGE	13	INTERNAL 4	23	DEVICENET FAULT
4	LOW BUS VOLTAGE	14	INTERNAL 5	24	DNET TRIGGER FAULT
5	MOTOR OVERLOAD	15	INTERNAL 6	25	RESERVED
6	CONTROL FAULT	16	INTERNAL 7	26	RESERVED
7	EXTERNAL FAULT	17	INTERNAL 8	27	RESERVED
8	OEM DATA FAILED	18	INTERNAL 9		
9	START ERROR	19	INTERNAL 10		

**DNET Par. ID 9 through 16 - Reserved.**

**DNET Par. ID 17 - BUS OFF ERROR:** Determines how the Communication Section processes a CAN Bus OFF condition.

0 - Hold CAN chip in bus off state when bus off is detected.

1 - Tries to reset the CAN and continue communication.

**DNET Par. ID 18 - BUS OFF COUNT:** Number of times the CAN peripheral went into bus off state. Counter maximum value is 255. Any write into this parameter resets the counter to 0.

**DNET Par. ID 19 - DEVICENET IDLE MODE:** This parameter is used to set the action the SCD drive should perform when the connection is closed (set to idle state) and drive is still in DNET control.

0 - STOP the drive if IDLE mode

1 - Hold last state if IDLE mode (**WARNING!** Make sure it is safe to operate this way!)

**DNET Par. ID 20 - CONTROL SOURCE:** Must be set to NETWORK CONTROL before network RUN FWD or RUN REV will be accepted.

0 - Local control (from SCD terminals)

1 - NETWORK CONTROL (**WARNING!** Make sure it is safe to operate the drive!)

Object Map - Control Supervisor Object 0x29-1-5

If this parameter (attribute) is set, the RUN STOP events are controlled by a combination of RUN FWD and RUN REV attributes (parameters) shown in the table in Section B.5.9.

**DNET Par. ID 21 - RUN FORWARD:** Request RUN Forward if Control is set to NETWORK

0 - STOP running FORWARD

1 - RUN FORWARD (**WARNING!** Make sure it is safe to operate the drive!)

Object Map - Control Supervisor Object 0x29-1-3

**DNET Par. ID 22 - RUN REVERSE:** Request RUN Forward if Control is set to NETWORK

0 - STOP running REVERSE

1 - RUN REVERSE (**WARNING!** Make sure it is safe to operate the drive!)

Object Map - Control Supervisor Object 0x29-1-4

**WARNING!**

Make sure it is safe to operate the SCD Series drive from the network! Damage to equipment and/or injury to personnel can result from unattended/improper operation.

**NOTE 1:** To run in reverse direction, Parameter #17 - ROTATION must be set to 2 (FORWARD and REVERSE)

**NOTE 2:** Local stop command (opening connection between terminals 1 and 4) overrides RUN/STOP command from DeviceNet™.

**DNET Par. ID 23 - FAULT RESET:** Transition from 0->1 clears the SCD fault.

0 - No Action

0 -> 1 - Fault RESET

Object Map - Control Supervisor Object 0x29-1-12

**DNET Par. ID 24 - PRESET COMMAND:** Allows preset speed reference while in network control.

0 - Local speed reference (keypad, analog)

1 - Preset #1 (ACT parameter #31)

2 - Preset #2 (ACT parameter #32)

3 - Preset #3 (ACT parameter #33)

4 - Preset #4 (ACT parameter #34)

5 - Preset #5 (ACT parameter #35)

6 - Preset #6 (ACT parameter #36)

7 - Preset #7 (ACT parameter #37)

**NOTE:** Preset speeds are only active when DeviceNet control is set but NOT network reference. If network reference is set, preset speed control is ignored.

**DNET Par. ID 25 - SPEED REFERENCE:**

0 - Local speed reference (SCD drive speed selection: keypad, presets, analog)  
1 - Network speed reference  
Object Map - AC Drive Object 0x2A-1-4

**NOTE: Parameter IDs 20-25 will reset to 0 when power is cycled or the drive is reset.**

**DNET Par. ID 26 - NETWORK COMMAND FREQUENCY:** Sets the drive command frequency if parameter ID #25 is set to NETWORK REFERENCE (0.1 Hz resolution).

**DNET Par. ID 27 - CONTROL SOURCE (READ ONLY)**

0 - Local control  
1 - Control from the Network  
Object Map - Control Supervisor Object 0x29-1-15

**DNET Par. ID 28 - SPEED REFERENCE SOURCE (READ ONLY)**

0 - Local speed reference  
1 - Network speed reference  
Object Map - AC Drive Object 0x2A-1-29

**DNET Par. ID 29 - DRIVE ACTUAL DIRECTION (READ ONLY)**

0 - Forward  
1 - Reverse

**DNET Par. ID 30 - RUN STATUS (READ ONLY):** See table below:

RUN STATUS					
NO.	STATUS	NO.	STATUS	NO.	STATUS
0	FAULT LOCKOUT	4	DC BRAKE	8	DECELERATION
1	FAULT	5	RUN AT 0 Hz	9	CURRENT LIMIT
2	START PENDING	6	RUN	10	DECEL OVERRIDE
3	STOP	7	ACCELERATION	11	LOWER ON SEQUENCE

**DNET Par. ID 31 - SPEED SOURCE (READ ONLY):** See table below:

SPEED SOURCE					
NO.	SOURCE	NO.	STATUS	NO.	STATUS
0	KEYPAD	5	PRESET SPEED #3	10	JOG SPEED
1	0- 10 VDC	6	PRESET SPEED #4	11	MOP SPEED
2	4- 20 mA	7	PRESET SPEED #5	12	DEVICENET
3	PRESET SPEED #1	8	PRESET SPEED #6		
4	PRESET SPEED #2	9	PRESET SPEED #7		

**DNET Par. ID 32:** Reserved.

**DNET Par. ID 33 - AT REFERENCE STATUS (READ ONLY)**

- 0 - Actual speed is different than commanded speed.
- 1 - Actual speed is equal to commanded speed (+0.5 Hz).

**DNET Par. ID 34:** Reserved.

**DNET Par. ID 35 - CHANGE OF STATE (COS) STATUS BITS (READ ONLY)**

**DNET Par. ID 36 - CHANGE OF STATE (COS) MASK BITS**

CHANGE OF STATE TRIGGER SETUP: Setting the trigger of the COS I/O connection is performed by specifying the trigger status bits in DeviceNet Parameter ID #35 COS STATUS. The status bits of Parameter #35 that will trigger the COS message are masked with "1" in Parameter #36 COS MASK.

Description of bits for DNET parameters ID #35 COS Status and ID #36 COS MASK:

DESCRIPTION OF BITS					
BIT	DESCRIPTION	BIT	DESCRIPTION	BIT	DESCRIPTION
0	FAULTED	6	REF. FROM NET.	12	ACCELERATION
1		7	AT REFERENCE	13	DECELERATION
2	RUNNING FORWARD	8	SPEED SOURCE 0*	14	CURRENT LIMIT
3	RUNNING REVERSE	9	SPEED SOURCE 1*	15	DECEL OVERRIDE
4	READY	10	SPEED SOURCE 2*		
5	CONTROL FROM NET.	11	SPEED SOURCE 3*		

\* See table below for Speed Source Selection.

SPEED SOURCE SELECTION				
BIT 11	BIT 10	BIT 9	BIT 8	SPEED SOURCE
0	0	0	0	KEYPAD
0	0	0	1	0 - 10 VDC
0	0	1	0	4 - 20 mA
0	0	1	1	PRESET SPEED #1
0	1	0	0	PRESET SPEED #2
0	1	0	1	PRESET SPEED #3
0	1	1	0	PRESET SPEED #4
0	1	1	1	PRESET SPEED #5
1	0	0	0	PRESET SPEED #6
1	0	0	1	PRESET SPEED #7
1	0	1	0	JOG (PRESET SPEED #2)
1	0	1	1	MOP*
1	1	0	0	NETWORK REFERENCE

\*MOP is asserted if TB-13B and TB-13C are both programmed for MOP

**DNET Par. ID 37:** Reserved.

**DNET Par. ID 38 - KEYPAD COMMAND FREQUENCY:** Allows the keypad speed (which is normally accessed using the ▲ and ▼ buttons on the front of the drive) to be changed through DeviceNet. This speed can be used as Preset Speed #0 in Output Assembly 103 and Parameter 24.

**DNET Par. ID 39:** Reserved.

**DNET Par. ID 40 - SCD DRIVE PARAMETER VERSION (READ ONLY):** Displays the parameter version number of the drive (example: 322). This is the same number that the drive displays when power is applied.

**DNET Par. ID 41 through 139:** Correspond to ACT Parameters 1 through 90 and are described in Section 15.0 - DESCRIPTION OF PARAMETERS.

**DNET Par. ID 140 - DEVICENET NODE ADDRESS (ACT PARAMETER C00):** DeviceNet address 0-63. Does not take effect until power to the drive is cycled.

**DNET Par. ID 141 - DEVICENET BAUD RATE (ACT PARAMETER C01)**

- 0 - 125kbps
- 1 - 250kbps
- 2 - 500kbps

**DNET Par. ID 142 - ACTION ON LOSS OF DEVICENET (ACT PARAMETER C02)**

- 0 - FAULT & STOP - Trigger the 'JF' Network fault if drive is running.
- 1 - IGNORE (do not do anything)
- 2 - AC TECH specific - Switch OFF control to TERMINAL and do not do anything (if drive was running, it will keep running in terminal mode)

**WARNING!** For settings 1 and 2, make sure it is safe to operate this way!

Object Map - Control Supervisor Object 0x29-1-16

**DNET Par. ID 143 - DEVICENET OUTPUT ASSEMBLY SELECTION (ACT PARAM. C03):**

Select the output assembly, consumption size, and path for polled I/O connection.

- |                             |   |
|-----------------------------|---|
| 1 = "1 Basic Contactor"     | - ODVA SPECIFIED  |
| 2 = "2 Basic Overload"      | - ODVA SPECIFIED  |
| 3 = "3 Basic Motor Starter" | - ODVA SPECIFIED  |
| 4 = "4 Ext. Contactor"      | - ODVA SPECIFIED  |
| 5 = "5 Ext. Motor Starter"  | - ODVA SPECIFIED  |
| 6 = "20 Basic Speed Ctrl"   | - ODVA SPECIFIED  |
| 7 = "21 Ext. Speed Ctrl"    | - ODVA SPECIFIED  |
| 8 = "100 Ext.Speed Ctrl Hz" | - AC TECH specific (Same as Assembly 21, except speed is in Hz) |
| 9 = "103 Preset Speed Ctrl" | - AC TECH specific  |

OUTPUT ASSEMBLY DETAILS:

<b>1 BASIC CONTACTOR OUTPUT ASSEMBLY</b>								
BYTE	BIT 7	BIT 6	BIT 5	BIT 4	BIT 3	BIT 2	BIT 1	BIT 0
0								RUN*

\* Implemented as RUN FORWARD

<b>2 BASIC OVERLOAD OUTPUT ASSEMBLY</b>								
BYTE	BIT 7	BIT 6	BIT 5	BIT 4	BIT 3	BIT 2	BIT 1	BIT 0
0						FAULT RESET		

<b>3 BASIC MOTOR STARTER OUTPUT ASSEMBLY</b>								
BYTE	BIT 7	BIT 6	BIT 5	BIT 4	BIT 3	BIT 2	BIT 1	BIT 0
0						FAULT RESET		RUN*

\* Implemented as RUN FORWARD

<b>4 EXTENDED CONTACTOR OUTPUT ASSEMBLY</b>								
BYTE	BIT 7	BIT 6	BIT 5	BIT 4	BIT 3	BIT 2	BIT 1	BIT 0
0							RUN REV	RUN FWD

<b>5 EXTENDED MOTOR STARTER OUTPUT ASSEMBLY</b>								
BYTE	BIT 7	BIT 6	BIT 5	BIT 4	BIT 3	BIT 2	BIT 1	BIT 0
0						FAULT RESET	RUN REV	RUN FWD

<b>20 BASIC SPEED CONTROL OUTPUT ASSEMBLY</b>								
BYTE	BIT 7	BIT 6	BIT 5	BIT 4	BIT 3	BIT 2	BIT 1	BIT 0
0						FAULT RESET		RUN FWD
1								
2	SPEED REFERENCE RPM (LOW BYTE)							
3	SPEED REFERENCE RPM (HIGH BYTE)							

21 EXTENDED SPEED CONTROL OUTPUT ASSEMBLY								
BYTE	BIT 7	BIT 6	BIT 5	BIT 4	BIT 3	BIT 2	BIT 1	BIT 0
0		NET. REF.	NET. CONTROL			FAULT RESET	RUN REV	RUN FWD
1								
2	SPEED REFERENCE RPM (LOW BYTE)							
3	SPEED REFERENCE RPM (HIGH BYTE)							

100 AC TECH EXTENDED SPEED CONTROL OUTPUT ASSEMBLY								
BYTE	BIT 7	BIT 6	BIT 5	BIT 4	BIT 3	BIT 2	BIT 1	BIT 0
0		NET. REF.	NET. CONTROL			FAULT RESET	RUN REV	RUN FWD
1								
2	SPEED REFERENCE Hz (LOW BYTE)							
3	SPEED REFERENCE Hz (HIGH BYTE)							

103 AC TECH PRESET SPEED CONTROL OUTPUT ASSEMBLY								
BYTE	BIT 7	BIT 6	BIT 5	BIT 4	BIT 3	BIT 2	BIT 1	BIT 0
0						FAULT RESET	RUN REV	RUN FWD
1						PRESET BIT 2	PRESET BIT 1	PRESET BIT 0

**NOTE 1:** Refer to the following table for Frequency Source Bits representation.

PRESET SPEED BITS REPRESENTATION			
BIT 2	BIT 1	BIT 0	SPEED SOURCE
0	0	0	LOCAL (keypad, analog)
0	0	1	PRESET SPEED #1
0	1	0	PRESET SPEED #2
0	1	1	PRESET SPEED #3
1	0	0	PRESET SPEED #4
1	0	1	PRESET SPEED #5
1	1	0	PRESET SPEED #6
1	1	1	PRESET SPEED #7

**NOTE 2:** Preset speeds are accepted only when DeviceNet control is set but NOT network reference. If network reference is set, preset speed control is ignored. To simplify setup, refer to the following parameters in the EDS file: Parameter 24 - DeviceNet Preset Command, and Parameter 38 - Keypad Command Frequency.

**DNET Par. ID 144 - DEVICENET INPUT ASSEMBLY SELECTION (ACT PARAM. C04):**

Select the input assembly, production size, and path for the following I/O connections:

- Polling
- Bit-Strobe
- Change of State
- Cyclic

- |                             |  |
|-----------------------------|--|
| 1 = "50 Basic Overload"     | - ODVA SPECIFIED                                       |
| 2 = "51 Extended Overload"  | - ODVA SPECIFIED                                       |
| 3 = "52 Basic Motor Ctrl"   | - ODVA SPECIFIED                                       |
| 4 = "53 Ext. Motor Ctrl 1"  | - ODVA SPECIFIED                                       |
| 5 = "54 Ext. Motor Ctrl 2"  | - ODVA SPECIFIED                                       |
| 6 = "70 Basic Speed Ctrl"   | - ODVA SPECIFIED                                       |
| 7 = "71 Ext. Speed Ctrl"    | - ODVA SPECIFIED                                       |
| 8 = "101 Ext.Speed Ctrl Hz" | - AC TECH specific (same as 71, except speed is in Hz) |
| 9 = "102 Custom Assembly"   | - AC TECH specific                                     |
| 10 = "104 Custom Assembly"  | - AC TECH specific                                     |
| 11 = "105 Custom Assembly"  | - AC TECH specific                                     |

**INPUT ASSEMBLY DETAILS:**

50 BASIC OVERLOAD/CONTACTOR INPUT ASSEMBLY								
BYTE	BIT 7	BIT 6	BIT 5	BIT 4	BIT 3	BIT 2	BIT 1	BIT 0
0								FAULTED

51 EXTENDED OVERLOAD/CONTACTOR INPUT ASSEMBLY								
BYTE	BIT 7	BIT 6	BIT 5	BIT 4	BIT 3	BIT 2	BIT 1	BIT 0
0			CONTROL FROM NET.					FAULTED

52 BASIC MOTOR CONTROL INPUT ASSEMBLY								
BYTE	BIT 7	BIT 6	BIT 5	BIT 4	BIT 3	BIT 2	BIT 1	BIT 0
0						RUNNING FORWARD		FAULTED/TRIP

53 EXTENDED MOTOR CONTROL 1 INPUT ASSEMBLY								
BYTE	BIT 7	BIT 6	BIT 5	BIT 4	BIT 3	BIT 2	BIT 1	BIT 0
0			CONTROL FROM NET.	READY		RUNNING FORWARD		FAULTED/TRIP

**54 EXTENDED MOTOR CONTROL 2 INPUT ASSEMBLY**

BYTE	BIT 7	BIT 6	BIT 5	BIT 4	BIT 3	BIT 2	BIT 1	BIT 0
0			CONTROL FROM NET.	READY	RUNNING REVERSE	RUNNING FORWARD		FAULTED/ TRIP

**70 BASIC SPEED CONTROL INPUT ASSEMBLY**

BYTE	BIT 7	BIT 6	BIT 5	BIT 4	BIT 3	BIT 2	BIT 1	BIT 0
0						RUNNING FORWARD		FAULTED/ TRIP
1								
2	ACTUAL SPEED RPM (LOW BYTE)							
3	ACTUAL SPEED RPM (HIGH BYTE)							

**71 EXTENDED SPEED CONTROL INPUT ASSEMBLY**

BYTE	BIT 7	BIT 6	BIT 5	BIT 4	BIT 3	BIT 2	BIT 1	BIT 0
0	AT REF.	REF. FROM NET.	CONTROL FROM NET.	READY	RUNNING REVERSE	RUNNING FORWARD		FAULTED/ TRIP
1								
2	ACTUAL SPEED RPM (LOW BYTE)							
3	ACTUAL SPEED RPM (HIGH BYTE)							

**101 AC TECH EXTENDED SPEED CONTROL INPUT ASSEMBLY**

BYTE	BIT 7	BIT 6	BIT 5	BIT 4	BIT 3	BIT 2	BIT 1	BIT 0
0	AT REF.	REF. FROM NET.	CONTROL FROM NET.	READY	RUNNING REVERSE	RUNNING FORWARD		FAULTED/ TRIP
1								
2	ACTUAL SPEED Hz (LOW BYTE)							
3	ACTUAL SPEED Hz (HIGH BYTE)							

102 CUSTOM INPUT ASSEMBLY		
WORD	BYTE	
0	0	VALUE OF DNET PARAMETER POINTED BY ACT PARAMETER #C05 (Low Byte)
	1	VALUE OF DNET PARAMETER POINTED BY ACT PARAMETER #C05 (High Byte)
1	2	VALUE OF DNET PARAMETER POINTED BY ACT PARAMETER #C06 (Low Byte)
	3	VALUE OF DNET PARAMETER POINTED BY ACT PARAMETER #C06 (High Byte)
2	4	VALUE OF DNET PARAMETER POINTED BY ACT PARAMETER #C07 (Low Byte)
	5	VALUE OF DNET PARAMETER POINTED BY ACT PARAMETER #C07(High Byte)
3	6	VALUE OF DNET PARAMETER POINTED BY ACT PARAMETER #C08 (Low Byte)
	7	VALUE OF DNET PARAMETER POINTED BY ACT PARAMETER #C08 (High Byte)

104 CUSTOM INPUT ASSEMBLY									
WORD	BYTE	BIT 7	BIT 6	BIT 5	BIT 4	BIT 3	BIT 2	BIT 1	BIT 0
0	0	FAULT		DECEL	ACCEL	ROT. DIRECT.	COM. DIRECT.	RUNNING	ENABLED
	1	FREQ. SRC.	FREQ. SRC.	FREQ. SRC.	FREQ. SRC.	LOCAL	LOCAL	LOCAL	AT SPEED
1	2	ACTUAL SPEED SCALE 0-32767 (LOW BYTE)							
	3	ACTUAL SPEED SCALE 0-32767 (HIGH BYTE)							

105 CUSTOM INPUT ASSEMBLY									
WORD	BYTE	BIT 7	BIT 6	BIT 5	BIT 4	BIT 3	BIT 2	BIT 1	BIT 0
0	0	FAULT		DECEL	ACCEL	ROT. DIRECT.	COM. DIRECT.	RUNNING	ENABLED
	1	FREQ. SRC.	FREQ. SRC.	FREQ. SRC.	FREQ. SRC.	LOCAL	LOCAL	LOCAL	AT SPEED
1	2	ACTUAL SPEED SCALE 0-32767 (Low Byte)							
	3	ACTUAL SPEED SCALE 0-32767 (High Byte)							
2	4	VALUE OF DNET PARAMETER POINTED BY ACT PARAMETER #C07 (Low Byte)							
	5	VALUE OF DNET PARAMETER POINTED BY ACT PARAMETER #C07 (High Byte)							
3	6	VALUE OF DNET PARAMETER POINTED BY ACT PARAMETER #C08 (Low Byte)							
	7	VALUE OF DNET PARAMETER POINTED BY ACT PARAMETER #C08 (High Byte)							

**NOTE 1:** For Rotation and Commanded Direction, 1 = Forward and 0 = Reverse.

**NOTE 2:** Refer to the following tables for Local Bits and Frequency Source Bits representation.

**NOTE 3:** Actual Speed Scale: 0 = 0.0 Hz and 32767 = Max. Frequency (DNet ID 64; ACT par. 24).

LOCAL BITS REPRESENTATION			
BIT 3	BIT 2	BIT 1	CONTROL
0	0	0	TERMINAL
0	0	1	NETWORK

FREQUENCY SOURCE BITS REPRESENTATION				
BIT 7	BIT 6	BIT 5	BIT 4	SPEED SOURCE
0	0	0	0	KEYPAD
0	0	0	1	PRESET SPEED #1
0	0	1	0	PRESET SPEED #2
0	0	1	1	PRESET SPEED #3
0	1	0	0	PRESET SPEED #4
0	1	0	1	PRESET SPEED #5
0	1	1	0	PRESET SPEED #6
0	1	1	1	PRESET SPEED #7
1	0	0	0	TERMINAL REFERENCE (analog, MOP)
1	0	0	1	NETWORK REFERENCE

**DNET Par. ID 145 - CUSTOM INPUT ASSEMBLY WORD 0 ADDRESS (ACT Param. C05):**

DNET parameter ID whose value is placed in bytes 0 and 1 of Custom Input Assembly 102.

**DNET Par. ID 146 - CUSTOM INPUT ASSEMBLY WORD 1 ADDRESS (ACT Param. C06):**

DNET parameter ID whose value is placed in bytes 2 and 3 of Custom Input Assembly 102.

**DNET Par. ID 147 - CUSTOM INPUT ASSEMBLY WORD 2 ADDRESS (ACT Param. C07):**

DNET parameter ID whose value is placed in bytes 4 and 5 of Custom Input Assembly 102, and in bytes 4 and 5 of Custom Input Assembly 105.

**DNET Par. ID 148 - CUSTOM INPUT ASSEMBLY WORD 3 ADDRESS (ACT Param. C08):**

DNET parameter ID whose value is placed in bytes 6 and 7 of Custom Input Assembly 102, and in bytes 6 and 7 of Custom Input Assembly 105.

**NOTE:** A value of zero in Parameter IDs 145 to 148 defines the end of Assembly 102. A value of zero in Parameter IDs 147 to 148 defines the end of Assembly 105.

**DNET Par. ID 149 - DEVICENET MOTOR TYPE (ACT Parameter C09):** See table below:

<b>MOTOR TYPES</b>			
NO.	DESCRIPTION	NO.	DESCRIPTION
0	NON-STANDARD MOTOR	6	WOUND ROTOR INDUCTION
1	PM DC MOTOR	7	SQUIRREL CAGE INDUCTION
2	FC DC MOTOR	8	STEPPER MOTOR
3	PM SYNCHRONOUS MOTOR	9	SINUSOIDAL PM BL
4	FC SYNCHRONOUS MOTOR	10	TRAPEZOIDAL PM BL
5	SWITCHED RELUCTANCE		

**DNET Par. ID 150 - DEVICENET DIAGNOSTICS (ACT Parameter C10) (READ ONLY):**

See tables below:

<b>LEFT DIGIT - CONTROL STATUS</b>	
NO.	DESCRIPTION
0	LOCAL CONTROL
1	NETWORK CONTROL
2	ACT PARAMETER 14 - CONTROL SET TO "NETWORK ONLY" BUT NETWORK CONTROL IS NOT SET.

<b>MIDDLE DIGIT - NETWORK STATUS</b>			
NO.	DESCRIPTION	NO.	DESCRIPTION
0	NETWORK OFF	5	NETWORK CONNECTED
1	NETWORK NOT CONNECTED	6	
2	NETWORK CONNECTION TIMEOUT	7	
3	COMMUNICATION FAULTED	8	DUPLICATE MAC ID FAILURE
4		9	NETWORK CRITICAL LINK FAILURE

<b>RIGHT DIGIT - I/O STATUS</b>			
NO.	DESCRIPTION	NO.	DESCRIPTION
0	I/O CONNECTION OFF	5	I/O ACTIVE
1	I/O CONNECTION IDLE STATE	6	
2		7	
3	I/O FAULTED	8	
4		9	I/O CRITICAL ERROR

## B.7 NETWORK TROUBLESHOOTING

To aid in troubleshooting parameter number C10 can be accessed without entering PASSWORD. Simply press the MODE button twice to "skip" over the PASSWORD prompt and "P50" will be displayed. Then use the ▲ and ▼ buttons to scroll to C10 which displays the status of the DeviceNet™ connection.

NETWORK TROUBLESHOOTING		
SYMPTOM	POSSIBLE CAUSE	REMEDY
SCD Drive cannot be accessed from network; C10 code is "083".	<ul style="list-style-type: none"> <li>- Duplicate DeviceNet address</li> </ul>	<ul style="list-style-type: none"> <li>- Ensure SCD drive address is unique.</li> <li>- Reset SCD drive by cycling power.</li> <li>- Use Faulted Node Recovery utility.</li> </ul>
SCD Drive cannot be accessed from network; C10 code is "093".	<ul style="list-style-type: none"> <li>- Communication section is not receiving power.</li> <li>- Network was not powered up before the SCD drive.</li> <li>- Invalid baud rate.</li> </ul>	<ul style="list-style-type: none"> <li>- Check DeviceNet connections and power.</li> <li>- Check the baud rate.</li> <li>- Ensure bias resistors were placed correctly.</li> <li>- Reset SCD drive by cycling power.</li> <li>- Contact AC Tech Service Dept.</li> </ul>
SCD drive cannot be accessed from network; C10 code is different than 090 or "093".	<ul style="list-style-type: none"> <li>- Communication section is not receiving power.</li> <li>- Connection problem; shorted signal wires for example.</li> <li>- Scanner device failure.</li> </ul>	<ul style="list-style-type: none"> <li>- Check DeviceNet connections and power.</li> <li>- Check the scanner device.</li> </ul>
SCD drive stops and "JF" fault is displayed; C10 code is "x3x" or "xx3" (x = any number except 9).	<ul style="list-style-type: none"> <li>- SCD communication has been lost and the Watchdog Timer shut down the drive.</li> <li>- Communication was lost after the Master established communication.</li> <li>- Scanner device failure.</li> </ul>	<ul style="list-style-type: none"> <li>- Check the Master device.</li> <li>- Change expected packet rate if Master cannot handle the update rate.</li> <li>- Re-establish communication and clear the fault.</li> </ul>
SCD drive stops without a fault; C10 code is "111".	<ul style="list-style-type: none"> <li>- Master device closed established connection when SCD drive was in Network Control Mode, and Parameter ID #19 DeviceNet Idle Mode is set to 0 ("Stop the Drive").</li> </ul>	<ul style="list-style-type: none"> <li>- Switch Off Network Control before established connection is closed.</li> <li>- Set the DeviceNet Parameter ID #19 DeviceNet Idle Mode to 1 ("Hold Last State").</li> <li>- Re-establish connection and re-start the SCD drive.</li> </ul>
SCD drive stops and "nF" fault is displayed; C10 code is "xx" (x = any number).	<ul style="list-style-type: none"> <li>- Master device forced Network fault; Control Supervisor Object 0x29-1-17 "Force Fault Trip".</li> </ul>	<ul style="list-style-type: none"> <li>- Check Master device control logic.</li> </ul>

## EC DECLARATION OF CONFORMITY

In accordance with EN45014:1998

**Applied Council Directive(s):** EMC Directive 89/336/EEC, as amended: 92/31/EEC and Low Voltage Directive 73/23/EEC, as amended: 93/68/EEC

**We, Manufacturer:**

AC Technology Corporation  
660 Douglas Street  
Uxbridge, MA 01569  
U.S.A.

**Authorized Representative:**

AC Technology Europe  
4 Shackleton Way  
Bowbrook  
Shrewsbury, Shropshire SY3 8SW U.K.

declare under our sole responsibility that the products to which this Declaration relates, are in conformity with the relevant provisions of the following standards, provided that installations are carried out in accordance with manufacturer's instructions.

### PRODUCTS RELATED TO DECLARATION

SCD Series AC Variable Frequency Motor Drives Models:

SD203Y	SD250Y	SD275	SD415	SD4150	SD550
SD205Y	SD210	SD2100	SD420	SD4200	SD575
SD210Y	SD215	SD2150	SD430	SD4250	SD5100
SD215Y	SD220	SD2200	SD450	SD510	SD5150
SD220Y	SD230	SD405	SD475	SD520	SD5200
SD230Y	SD250	SD410	SD4100	SD530	SD5250

**NOTE:** Model numbers may be followed by: "F" (through-hole mount), "F1" (through-hole mount without heatsink), "P" (PI setpoint), and/or "V" (high frequency output)

### RELEVANT EUROPEAN STANDARDS

EN 50081-2\* Electromagnetic compatibility

– Generic emission standard – Part 2: Industrial environment

EN 50082-2\* Electromagnetic compatibility

– Generic immunity standard – Part 2: Industrial environment

EN 50178:1998 Electronic equipment for use in power installations

\* with suitable line filters that are properly installed.

### YEAR OF CE Marking (Low Voltage Directive): 2002

Signature:

  
Jim Reinwald, Compliance Manager

Date:

3 January 2002