

## QC3000 Series



- NEMA 1 & Chassis: 2 - 250 HP
- Variable Torque (for HVAC)
- Rugged industrial design
- Plain English programming

The QC3000 Series general purpose AC motor drives are designed for variable torque applications (centrifugal pumps and fans) and are available in NEMA 1 and chassis models.

For constant torque applications (such as conveyors, vibratory feeders, rock crushers, punch presses, etc.), select the QC1000 or QC2000 Series.

### Standard Features

- Input voltage ratings: 208, 230, 240, 380, 415, 460, 480, 575, 590 Vac (+10%, -15%) at 50 to 60 Hz.
- Full Protection: Ground Fault, Phase to Phase, Over Voltage, Under Voltage, Over Temperature, and Motor Over Current.
- 19 button tactile feedback keypad. Choice of scrolling or direct input of values for quick, easy setup.
- 32 character backlit display. Gives simultaneous indication of status, speed, load, direction, and speed reference type.
- Built in speed/frequency, load/amp, kilowatt hour, and elapsed time indicator. Speed indicator can be set to read Hz, RPM, % Speed, /S, /M, /H, #/S, #/M, #/H.
- Programmable automatic restart after fault or power outage. Speed search function to catch a spinning load.
- Three (3) selectable critical frequency avoidance ranges with adjustable skip bandwidth.
- Speed Follower Inputs: Speed pot, 4 to 20 mA (or 20 to 4 mA), 0 to 10 VDC (or 10 to 0 VDC).
- Keypad controls include: Start/Stop, Speed, Manual/Automatic, Jog, and Forward/Reverse.
- Output signals proportional to speed and load.

Operating Mode

```
RUN 1750 RPM
126 AMPS FWD KEY
```

Program Mode

```
137: CARRIER FREQ
10 KHZ
```

Monitor Mode

```
TOTAL KW HOURS
21382 KWH
```

- RS232 serial communications (RS485 optional.)
- Two levels of password protection assures security.
- Electronic DC Injection Braking.
- Two Form "C" auxiliary relays and one open-collector output. Each programmable for: Run, Fault, Fault Lockout, At Speed, Above Set Speed, Current Limit, Follower Present, Maintenance Target, Auto Speed Mode, or Start Pending.
- Comprehensive Diagnostics: Logs ten previous faults in non-volatile memory. In addition to the description of the fault, the time and drive operating status at the time of the fault are given.
- Slip compensation for tighter speed regulation during load fluctuations. Automatic or manual boost for increased starting and accelerating torque.
- Adjustable jog speed and seven preset speeds. Each with individual accel and decel rates.
- 400 millisecond ride through keeps drive on line through short duration power dips (2 second extended ride through optional).
- QC3000 units have removable mounting feet for easy through panel mounting.

## Operation

AC Tech's QC Series drives are extremely easy to operate. The 32 character LCD display gives complete drive status by simultaneously displaying:

- Drive Status: STOP, ACCEL, RUN, DECEL, FAULT.
- Commanded Speed: In units of Hz, RPM, %RPM, /S, /M, /H, #/M, and #/H.
- Load as a percentage or actual amps.
- Rotation Direction: Forward or Reverse.
- Speed Reference Source: Keypad, Speed Pot, mA, VDC, Presets Speeds.

The QC Series has a Monitor Mode which displays Time Since Start, Total Elapsed Run Time, and Total KWH. A programmable "Maintenance Target" alarm can alert the operator with a display message (or a contact closure) when to perform scheduled maintenance on the driven equipment. The alarm is set in hours of elapsed run time.

## Programming

Programming is menu driven in plain English rather than in codes or symbols. Both the parameter name and the value are displayed simultaneously. Over eighty programmable parameters give the highest degree of flexibility available.

## Parameter Summary

- Current Limit: 120% for one minute
- Thermal overload: "Inverse I<sup>2</sup>T" electronic motor overload protection (UL approved).
- Slip Compensation: 1% or better speed regulation.
- Speed follower signal calibration: Scales 4-20 mA or 0-10 VDC signal. Signal can be direct or reverse acting.
- Separate accel and decel: 0.1 to 3600.0 Seconds.
- 7 preset speeds with separate accels and decels.
- Jog speed with separate accel and decel.
- Three critical frequency avoidance ranges with common adjustable skip bandwidth.
- Analog output signals: Proportional to speed and load.
- Analog output signal calibration: Scales output signals for meters, master/slaves setups, or other functions.

- Minimum and maximum frequency adjustment: Up to 120 Hz.
- Stop method: Coast or ramp to stop.
- Forward and/or reverse: Enable or lockout.
- Auto/Manual key: Enable or lockout.
- Restart "On the Fly" after power outage or fault: Catches a spinning load and resumes set speed.
- DC injection braking: Continuous or timed on start, on stop, at zero speed, start & stop, or zero speed & stop, with programmable maximum load level.
- Speed display units and scaling.
- Load/Amps display selection and scaling.
- Base frequency: Determines V/Hz ratio.
- V/Hz curve type (Constant Torque or Variable Torque Patterns).
- Auto (accelerating) and manual (starting) boost.
- Programming of two Form "C" auxiliary relays and one open-collector output for: Run, Fault, Fault Lockout, At Speed, Above Set Speed, Current Limit, Follower Present, Maintenance Target, Auto Speed Mode, or Start Pending.
- Passwords: Two levels of protection with programmable passwords.
- Diagnostic log: Maintains a history of last ten faults in non-volatile memory.

## Standard Options

- Door interlocked disconnect switch.
- Input line fuses.
- Input line reactor (line reactors are standard on 240 and 480 Vac units at 25HP and above, and on 590 Vac units at 5 HP and above).
- Panel mount remote keypad.
- Manual or automatic bypass.
- NEMA 12 enclosed VFD/Bypass package.
- Extended power loss ride through.
- PID Setpoint Control Software.
- RS485 serial communications (Modbus or Metasys® protocols).

## QC3000 Ratings and Dimensions

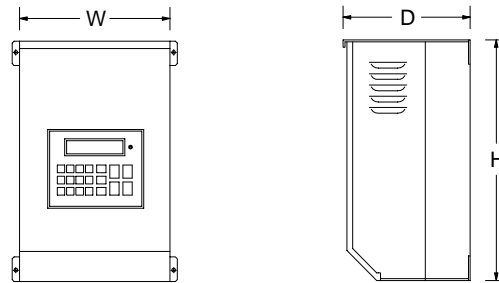

Typical NEMA 1 Enclosure

HP	INPUT VOLTAGE	OUTPUT CURRENT	MODEL NUMBER	NEMA 1 DIMENSIONS		
				H	W	D
2	240 / 200	6.8	Q32002B	12.00	7.44	7.91
	480 / 400	3.4	Q34002B	12.00	7.44	7.91
	590 / 480	2.7	Q35002B	12.00	7.44	7.91
3	240 / 200	9.6	Q32003B	12.00	7.44	7.91
	480 / 400	4.8	Q34003B	12.00	7.44	7.91
	590 / 480	3.9	Q35003B	12.00	7.44	7.91
5	240 / 200	15.2	Q32005B	12.00	7.44	7.91
	480 / 400	7.6	Q34005B	12.00	7.44	7.91
	590 / 480	6.1	Q35005B	15.50	7.44	7.91
7.5	240 / 200	22	Q32008B	12.00	7.44	7.91
	480 / 400	11.0	Q34008B	12.00	7.44	7.91
	590 / 480	9.0	Q35008B	15.50	7.44	7.91
10	240 / 200	28	Q32010B	14.00	8.88	9.50
	480 / 400	14.0	Q34010B	12.00	7.44	7.91
	590 / 480	11.0	Q35010B	15.50	7.44	7.91
15	240 / 200	42	Q32015B	14.00	8.88	9.50
	480 / 400	21	Q34015B	14.00	8.88	9.50
	590 / 480	17.0	Q35015B	19.00	8.88	9.84
20	240 / 200	54	Q32020B	19.00	8.88	9.84
	480 / 400	27	Q34020B	19.00	8.88	9.84
	590 / 480	22	Q35020B	25.00	8.88	10.50
25	240 / 200	68	Q32025B	25.00	8.88	10.50
	480 / 400	34	Q34025B	25.00	8.88	10.50
	590 / 480	27	Q35025B	25.00	8.88	10.50
30	240 / 200	80	Q32030B	25.00	8.88	10.50
	480 / 400	40	Q34030B	25.00	8.88	10.50
	590 / 480	32	Q35030B	25.00	8.88	10.50
40	240 / 200	104	Q32040B	25.00	13.00	10.50
	480 / 400	52	Q34040B	25.00	13.00	10.50
	590 / 480	41	Q35040B	25.00	13.00	10.50
50	240 / 200	130	Q32050B	25.00	13.00	10.50
	480 / 400	65	Q34050B	25.00	13.00	10.50
	590 / 480	52	Q35050B	25.00	13.00	10.50
60	240 / 200	154	Q32060B	47.00	16.64	11.85
	480 / 400	77	Q34060B	25.00	13.00	10.50
	590 / 480	62	Q35060B	25.00	13.00	10.50
75	240 / 200	192	Q32075B	47.00	16.64	11.85
	480 / 400	96	Q34075B	29.00	16.64	11.85
	590 / 480	77	Q35075B	29.00	16.64	11.85
100	480 / 400	124	Q34100B	29.00	16.64	11.85
	590 / 480	99	Q35100B	29.00	16.64	11.85
125	480 / 400	156	Q34125B	29.00	24.42	11.85
	590 / 480	125	Q35125B	29.00	24.42	11.85
150	480 / 400	180	Q34150B	29.00	24.42	11.85
	590 / 480	144	Q35150B	29.00	24.42	11.85
200	480 / 400	240	Q34200B	29.00	36.66	11.85
	590 / 480	192	Q35200B	29.00	36.66	11.85
250	480 / 400	300	Q34250B	29.00	36.66	11.85

## QC3000 Environmental and Electrical Specifications

Storage Temperature	-20 to 70 C
Ambient Operating Temp.	-10 to 40 C
Ambient Humidity	Less than 95% (non-condensing)
Altitude (without derating)	3300 ft (1000 m) above sea level
Input Line Voltages	240/200 Vac, 480/400 Vac, 590/480 Vac
Input Voltage Tolerance	+10%, -15%
Input Frequency Tolerance	48 to 62 Hz
Output Wave Form	Sine Coded PWM (Pulse Width Modulated)
Output Frequency	0 - 120 Hz (optional ranges to 650 Hz)
Carrier Frequency <sup>1</sup>	1.5 kHz, 8 kHz, 10 kHz, 12 kHz
Service Factor	1.00
Efficiency	97% or better
Power Factor (displacement)	0.96 or better
Overload Current Capacity	120% for 60 seconds
Speed Reference Follower	0-5 VDC, 0-10 VDC, 4-20 mA
Analog Outputs <sup>2</sup>	
Proportional to Frequency	0-10 VDC, 4-20 mA, 12 VDC Pulse Train
Proportional to Load	0-10 VDC, 2-10 VDC, 4-20 mA
Digital Outputs (Programmable)	(2) Form C relays: 2 amps at 120 Vac or 28 VDC (1) Open-collector output: 40 mA at 30 VDC

<sup>1</sup> Maximum carrier frequency on 590/480 Vac models rated 150 HP and 200 HP, and 480/400 Vac models rated 250 Hp, is 1.5 kHz.

<sup>2</sup> There is one 4-20 mA signal that can be selected to indicate frequency or load.

## Bypass Schematic (bypass is an optional feature)

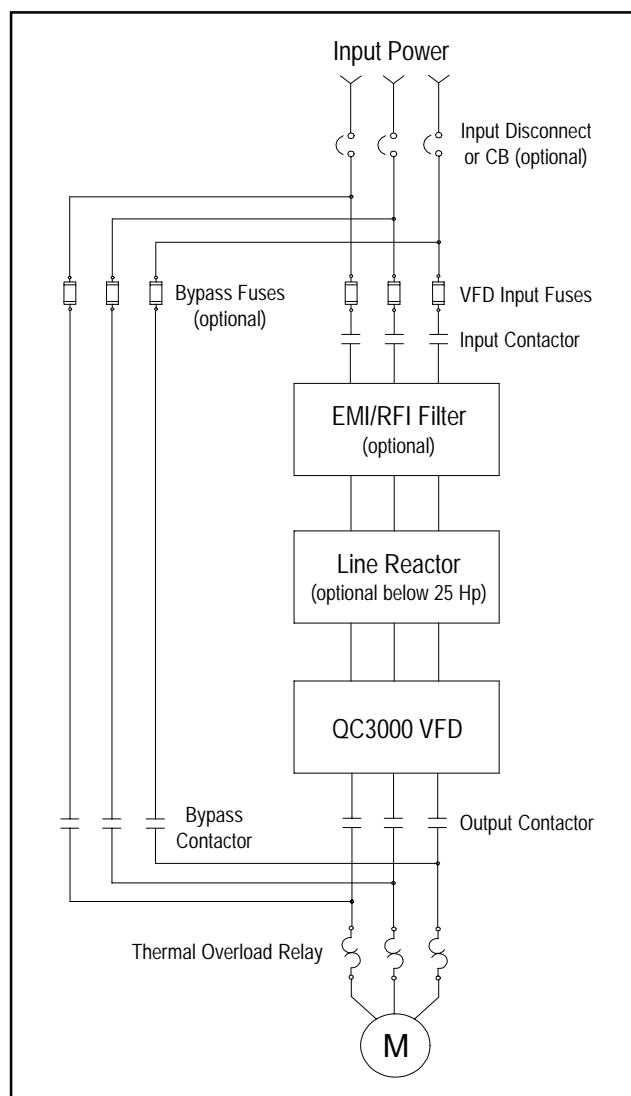

## AC Tech, committed to AC Drives!

AC Technology Corporation is dedicated to producing the finest AC Variable Frequency Drives available. At AC Tech, drives are our business, our only business. This focus has brought success that is reflected in our growth that has far outpaced the average growth of the industry. AC Tech's continual innovation and a flexibility cannot be found in companies that divide their attention and resources among many diverse product lines.

AC Tech pioneered many developments in AC variable frequency drives such as 575 Vac models (AC Tech is the largest supplier of 575 Vac drives to Canada), stainless steel (NEMA 4X) enclosed drives, plain English programming utilizing LCD technology, and the use of Intelligent Power Modules (IPM). AC Tech's commitment to quality, innovation and value is a personal one, shared by all employees.