

## MC3000 FAULT MESSAGES

| FAULT             | DESCRIPTION  |
|-------------------|--|
| <b>OUTPUT</b>     | Output Transistor fault; Output current exceeded 200%. May be ground fault or short circuit. |
| <b>LO VOLTS</b>   | Low DC Bus Voltage fault: DC bus voltage dropped below 60%. May be low line voltage          |
| <b>HI VOLTS</b>   | High DC Bus Voltage fault: DC bus voltage exceeded 120%. May be overhauling load.            |
| <b>HI TEMP</b>    | High Temperature fault: Heatsink or ambient temperature too high.                            |
| <b>OVERLOAD</b>   | Current Overload fault: Output current exceeded 100% for too long. VFD may be undersized.    |
| <b>PWR TRAN</b>   | Power Transient fault.   |
| <b>PWR SAG</b>    | Power Sag fault: New control board installed. Perform factory reset using Parameter 65.      |
| <b>LANGUAGE</b>   | Language EEPROM fault.   |
| <b>EXTERNAL</b>   | External fault: TB-13D activated (Parameter 50).   |
| <b>DB ERROR</b>   | Dynamic Brake fault: DB Resistors overloaded.  |
| <b>CONTROL</b>    | Control Board fault: New software installed. Perform factory reset using Parameter 65.       |
| <b>INTERNAL</b>   | Internal fault.  |
| <b>INTERN (#)</b> | Internal fault.  |
| <b>FOLLOWER</b>   | Loss of Follower fault: 4-20 mA signal at TB-5B dropped below 2 mA (Parameter 55).           |

## MC3000 FAULT HISTORY

Parameter 99 - FAULT HISTORY stores the last eight faults that tripped the drive. The FAULT HISTORY indicates the number of the fault (number 1 is the most recent fault), the fault message, and the status of the drive at the time of the fault. An example is shown below:

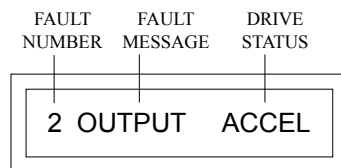

In the example above, the second fault is being viewed, which is an OUTPUT fault that occurred while the drive was accelerating.

## MC3000 PARAMETERS

| NO. | PARAMETER NAME | FACTORY DEFAULT | NO. | PARAMETER NAME | FACTORY DEFAULT |
|-----|----------------|-----------------|-----|----------------|-----------------|
| 0   | LINE VOLTS     | AUTO            | 41  | AIN FLTR       | 0.02 SEC        |
| 1   | SPEED #1       | 20.00 HZ        | 42  | TB10A OUT      | NONE            |
| 2   | SPEED #2       | 20.00 HZ        | 43  | @TB10A         | 60.00 HZ        |
| 3   | SPEED #3       | 20.00 HZ        | 44  | TB10B OUT      | NONE            |
| 4   | SPEED #4       | 20.00 HZ        | 45  | @TB10B         | 125 %           |
| 5   | SKIP #1        | .00 HZ          | 47  | TB13A          | NONE            |
| 6   | SKIP #2        | .00 HZ          | 48  | TB13B          | NONE            |
| 7   | BAND WID       | 1.00 HZ         | 49  | TB13C          | NONE            |
| 8   | ACCEL          | 30.0 SEC        | 50  | TB13D          | EXT FAULT       |
| 9   | DECEL          | 30.0 SEC        | 52  | TB14 OUT       | NONE            |
| 10  | MIN FRQ        | .50 HZ          | 53  | TB15 OUT       | NONE            |
| 11  | MAX FRQ        | 60.00 HZ        | 54  | RELAY          | NONE            |
| 12  | DC BRAKE       | .0 VDC          | 55  | TB5B LOSS      | FAULT           |
| 13  | DC TIME        | .0 SEC          | 57  | SERIAL         | DISABLE         |
| 14  | DYN BRAKE      | OFF             | 58  | ADDRESS        | 30              |
| 16  | CURRENT        | 180 %           | 61  | PASSWORD       | 0019            |
| 17  | MOTOR OL       | 100 %           | 63  | SOFTWARE       | (NOTE 2)        |
| 18  | BASE           | 60.00 HZ        | 64  | MONITOR        | ON              |
| 19  | FX BOOST       | (NOTE 1)        | 65  | PROGRAM        | RESET 60        |
| 22  | TORQUE         | CONSTANT        | 66  | HISTORY        | MAINTAIN        |
| 23  | CARRIER        | 2.5 KHZ         | 70  | PID MODE       | OFF             |
| 25  | START          | NORMAL          | 74  | PID FB         | TB-5B           |
| 26  | STOP           | COAST           | 75  | FB @ MIN       | 0.00 %          |
| 28  | AUTO / MAN     | BOTH            | 76  | FB @ MAX       | 100.0 %         |
| 30  | CONTROL        | LOCAL           | 77  | P GAIN         | 5.00 %          |
| 31  | UNITS          | HERTZ           | 78  | I GAIN         | 0.0 SEC         |
| 32  | HZ MULT        | 1.00            | 79  | D GAIN         | 0.0 SEC         |
| 33  | UNITS DP       | XXXXX           | 80  | PID ACC        | 30.0 SEC        |
| 34  | LOAD MLT       | 100 %           | 81  | MIN ALRM       | 0.00 %          |
| 35  | CONTRAST       | MED             | 82  | MAX ALRM       | 0.00 %          |
| 36  | SLEEP TH       | .00 HZ          | 98  | LANGUAGE       | ENGLISH         |
| 37  | SLEEP DL       | 30.0 SEC        | 99  | FAULT HISTORY  | (NOTE 2)        |
| 39  | TB5 MIN        | .00 HZ          |     |                |                 |
| 40  | TB5 MAX        | 60.00 HZ        |     |                |                 |

**NOTE 1:** REFER TO THE MC3000 MANUAL.

**NOTE 2:** THESE PARAMETERS ARE VIEW-ONLY.

QRM3-OEOD

# AC Tech

member of the **Lenze** Group

Drive for Global Excellence



## MC3000 Series Quick Reference Guide

**NOTE:** Before installing and operating the MC3000 drive, please read and become familiar with the MC3000 Series Installation and Operation Manual.

CTi Automation □ □

(800) 894-0412 (Toll Free) □ □ □

(208) 368-0415 (Fax) □ □

[info@ctiautomation.net](mailto:info@ctiautomation.net) □ □

[www.ctiautomation.net](http://www.ctiautomation.net)

## THE MC3000 KEYPAD

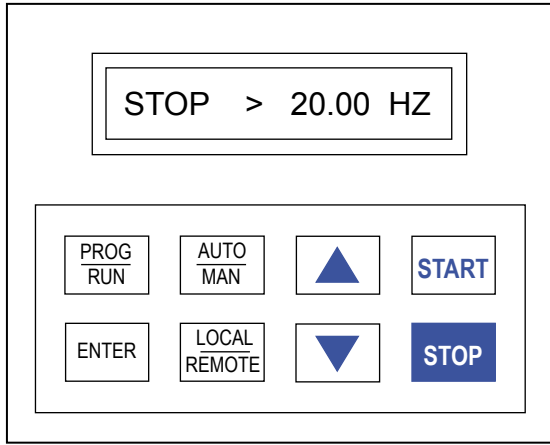

## PROGRAMMING THE MC3000 DRIVE

1. Press the PROG/RUN key. This will cause the PASSWORD prompt to appear (unless the password protection has been disabled), as shown below:

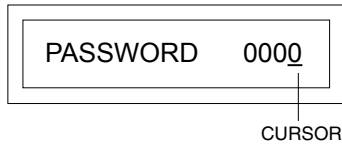

2. Use the ▲ and ▼ keys to scroll to the correct password value (the factory default password is 0019) and press ENTER. The PROGRAM mode will be entered at the start of the parameter menu. A cursor will highlight the parameter name.

3. Use the ▲ and ▼ keys to scroll to the desired parameter and press ENTER. The cursor will shift from the parameter name to the parameter value, as the example below illustrates:

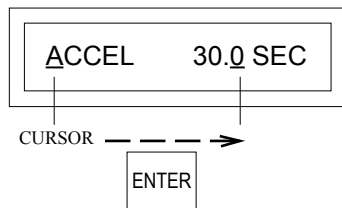

4. Use the ▲ and ▼ keys to scroll to the desired parameter value, and press ENTER to store the new value.
5. Press PROG/RUN to exit the PROGRAM mode.

## MC3000 KEYPAD FUNCTIONS

- START** Press the START key to start the drive. The START key is only active in LOCAL mode.
- STOP** Press the STOP key to stop the drive.  
**NOTE:** The STOP key is active in both LOCAL and REMOTE mode.  
The STOP key is also used to reset faults. If the fault condition has passed, pressing the STOP key will clear the fault and return the drive to a STOP condition.
- UP and DOWN ARROWS** - Used to change the speed setpoint in MANUAL mode, scroll through the parameter menu, and change parameter values.
- LOCAL REMOTE** Toggles between LOCAL (keypad) and REMOTE (terminal strip) start/stop control.  
**NOTE:** Parameter 30 - CONTROL must be set to KEYPAD or KEYPAD 2 for this key to be active.
- AUTO MAN** Toggles between AUTOMATIC (terminal strip) and MANUAL (keypad) speed control.  
**NOTE:** Parameter 28 - AUTO/MAN must be set to A/M LOC or A/M SPD for this key to be active.
- PROG RUN** Used to enter and exit the PROGRAM mode to set the parameters.
- ENTER** Used for: toggling the display between SPEED, LOAD, and MOTOR VOLTAGE; confirming new parameter values; confirming AUTO and MANUAL speed control selections; confirming LOCAL and REMOTE start/stop mode selections.  
Press and hold the ENTER key to activate the AUXILIARY MODE, which consists of two displays that cycle in one second intervals. One indicates LOCAL/REMOTE mode, AUTO/MANUAL mode, and the speed reference source, and the other is an elapsed time meter that indicates total run time.

## MC3000 DISPLAYS

Shown below are examples of MC3000 displays. To scroll through the SPEED, LOAD, and MOTOR VOLTAGE displays, press and release the ENTER key.

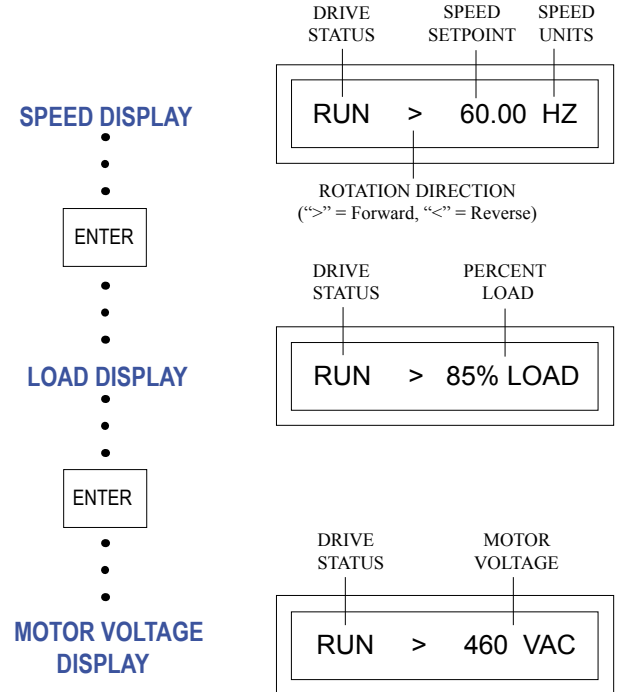

Press and hold the ENTER key to activate the AUXILIARY MODE, which will cycle in one second intervals between a CONTROL display and a TIME display. An example is shown below:

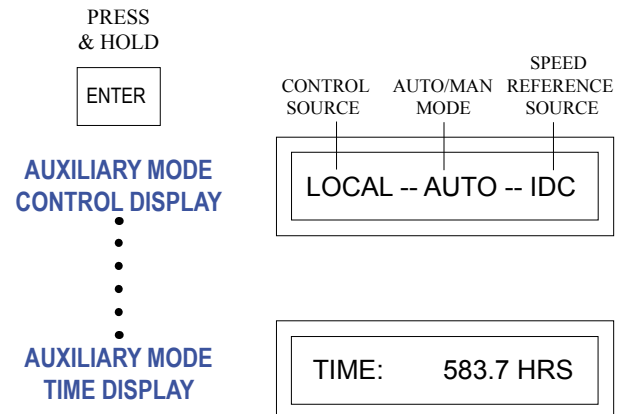

## MC1000 FAULT MESSAGES

| FAULT      | DESCRIPTION  |
|------------|--|
| OUTPUT     | Output Transistor fault; Output current exceeded 200%. May be ground fault or short circuit. |
| LO VOLTS   | Low DC Bus Voltage fault: DC bus voltage dropped below 60%. May be low line voltage.         |
| HI VOLTS   | High DC Bus Voltage fault: DC bus voltage exceeded 120%. May be overhauling load.            |
| HI TEMP    | High Temperature fault: Heatsink or ambient temperature too high.                            |
| OVERLOAD   | Current Overload fault: Output current exceeded 100% for too long. VFD may be undersized.    |
| PWR TRAN   | Power Transient fault.   |
| PWR SAG    | Power Sag fault: New control board installed. Perform factory reset using Parameter 65.      |
| LANGUAGE   | Language EEPROM fault.   |
| EXTERNAL   | External fault: TB-13D activated (Parameter 50).   |
| DB ERROR   | Dynamic Brake fault: DB Resistors overloaded.  |
| CONTROL    | Control Board fault: New software installed. Perform factory reset using Parameter 65.       |
| INTERNAL   | Internal fault.  |
| INTERN (#) | Internal fault.  |

## MC1000 FAULT HISTORY

Parameter 70 - FAULT HISTORY stores the last eight faults that tripped the drive. The FAULT HISTORY indicates the number of the fault (number 1 is the most recent fault), the fault message, and the status of the drive at the time of the fault. An example is shown below:

| FAULT NUMBER | FAULT MESSAGE | DRIVE STATUS |
|--------------|---------------|--------------|
| 2            | OUTPUT        | ACCEL        |

In the example above, the second fault is being viewed, which is an OUTPUT fault that occurred while the drive was accelerating.

## MC1000 PARAMETERS

| NO. | PARAMETER NAME | FACTORY DEFAULT | NO. | PARAMETER NAME | FACTORY DEFAULT |
|-----|----------------|-----------------|-----|----------------|-----------------|
| 0   | LINE VOLTS     | AUTO            | 32  | HZ MULT        | 1.00            |
| 1   | SPEED #1       | 20.00 HZ        | 33  | SPEED DP       | XXXXX           |
| 2   | SPEED #2       | 20.00 HZ        | 34  | LOAD MLT       | 100 %           |
| 3   | SPEED #3       | 20.00 HZ        | 35  | CONTRAST       | MED             |
| 4   | SPEED #4       | 20.00 HZ        | 36  | SLEEP TH       | .00 HZ          |
| 5   | SKIP #1        | .00 HZ          | 37  | SLEEP DL       | 30.0 SEC        |
| 6   | SKIP #2        | .00 HZ          | 39  | TB5 MIN        | .00 HZ          |
| 7   | BAND WID       | 1.00 HZ         | 40  | TB5 MAX        | 60.00 HZ        |
| 8   | ACCEL          | 30.0 SEC        | 41  | AIN FLTR       | 0.02 SEC        |
| 9   | DECEL          | 30.0 SEC        | 42  | TB10A OUT      | NONE            |
| 10  | MIN FRQ        | .50 HZ          | 43  | @TB10A         | 60.00 HZ        |
| 11  | MAX FRQ        | 60.00 HZ        | 44  | TB10B OUT      | NONE            |
| 12  | DC BRAKE       | .0 VDC          | 45  | @TB10B         | 125 %           |
| 13  | DC TIME        | .0 SEC          | 47  | TB13A          | NONE            |
| 14  | DYN BRAKE      | OFF             | 48  | TB13B          | NONE            |
| 16  | CURRENT        | 180 %           | 49  | TB13C          | NONE            |
| 17  | MOTOR OL       | 100 %           | 50  | TB13D          | EXT FAULT       |
| 18  | BASE           | 60.00 HZ        | 52  | TB14 OUT       | NONE            |
| 19  | FX BOOST       | (NOTE 1)        | 53  | TB15 OUT       | NONE            |
| 20  | AC BOOST       | .0 %            | 54  | RELAY          | NONE            |
| 21  | SLIP CMP       | .0 %            | 57  | SERIAL         | DISABLE         |
| 22  | TORQUE         | CONSTANT        | 58  | ADDRESS        | 30              |
| 23  | CARRIER        | 2.5 KHZ         | 61  | PASSWORD       | 0019            |
| 25  | START          | NORMAL          | 63  | SOFTWARE       | (NOTE 2)        |
| 26  | STOP           | COAST           | 64  | MONITOR        | ON              |
| 27  | ROTATION       | FORWARD         | 65  | PROGRAM        | RESET 60        |
| 28  | AUTO / MAN     | BOTH            | 66  | HISTORY        | MAINTAIN        |
| 29  | MANUAL         | KEYPAD          | 69  | LANGUAGE       | ENGLISH         |
| 30  | CONTROL        | LOCAL           | 70  | FAULT HISTORY  | (NOTE 2)        |
| 31  | UNITS          | HERTZ           |     |                |                 |

NOTE 1: REFER TO THE MC1000 MANUAL.

NOTE 2: THESE PARAMETERS ARE VIEW-ONLY.

# AC Tech

a member of the **Lenze Group**

Drive for Global Excellence

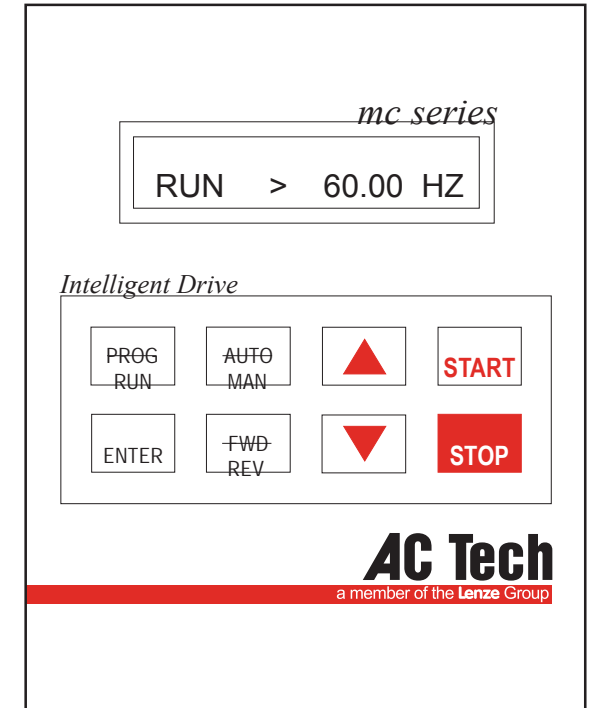

## MC1000 Series Quick Reference Guide

**NOTE:** Before installing and operating the MC1000 drive, please read and become familiar with the MC1000 Series Installation and Operation Manual.

CTi Automation  
 (800) 894-0412 (Toll Free)  
 (208) 368-0415 (Fax)  
[info@ctiautomation.net](mailto:info@ctiautomation.net)

## THE MC1000 KEYPAD

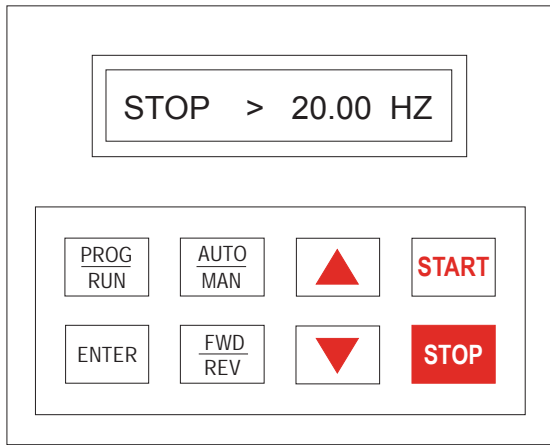

## PROGRAMMING THE MC1000 DRIVE

1. Press the PROG/RUN key. This will cause the PASSWORD prompt to appear (unless the password protection has been disabled), as shown below:

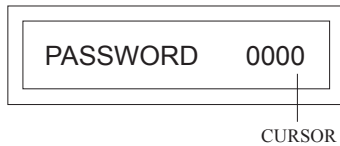

2. Use the ▲ and ▼ keys to scroll to the correct password value (the factory default password is 0019) and press ENTER. The PROGRAM mode will be entered at the start of the parameter menu. A cursor will highlight the parameter name.
3. Use the ▲ and ▼ keys to scroll to the desired parameter and press ENTER. The cursor will shift from the parameter name to the parameter value, as the example below illustrates:

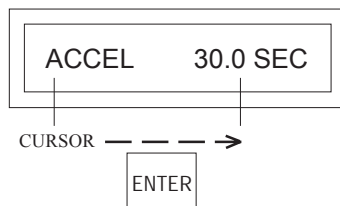

4. Use the ▲ and ▼ keys to scroll to the desired parameter value, and press ENTER to store the new value.
5. Press PROG/RUN to exit the PROGRAM mode.

## MC1000 KEYPAD FUNCTIONS

**START**

Press the START key to start the drive. The START key is only active in LOCAL mode.

**STOP**

Press the STOP key to stop the drive.

**NOTE:** The STOP key is active in both LOCAL and REMOTE mode.

The STOP key is also used to reset faults. If the fault condition has passed, pressing the STOP key will clear the fault and return the drive to a STOP condition.



UP and DOWN ARROWS - Used to change the speed setpoint in MANUAL mode, scroll through the parameter menu, and change parameter values.



Toggles between FORWARD and REVERSE rotation.  
**NOTE:** Parameter 27 - ROTATION must be set to FWD & REV, and the drive must be in LOCAL mode for this key to be active.



Toggles between AUTOMATIC (terminal strip) and MANUAL (keypad) speed control.  
**NOTE:** Parameter 28 - AUTO/MAN must be set to BOTH for this key to be active.



Used to enter and exit the PROGRAM mode to set the parameters.

**ENTER**

Used for: toggling the display between SPEED, LOAD, and MOTOR VOLTAGE; confirming new parameter values; confirming AUTO and MANUAL speed control selections; confirming LOCAL and REMOTE start/stop mode selections.

Press and hold the ENTER key to activate the AUXILIARY MODE, which consists of two displays that cycle in one second intervals. One indicates LOCAL/REMOTE mode, AUTO/MANUAL mode, and the speed reference source, and the other is an elapsed time meter that indicates total run time.

## MC1000 DISPLAYS

Shown below are examples of MC1000 displays. To scroll through the SPEED, LOAD, and MOTOR VOLTAGE displays, press and release the ENTER key.

### SPEED DISPLAY

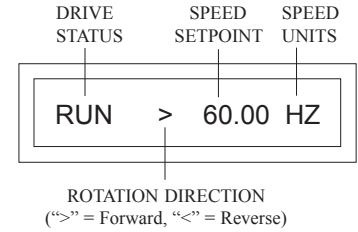

ENTER

### LOAD DISPLAY

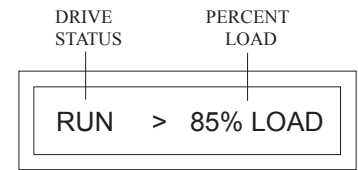

ENTER

### MOTOR VOLTAGE DISPLAY

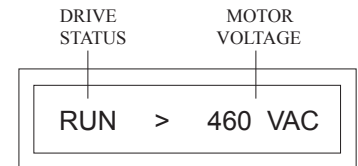

Press and hold the ENTER key to activate the AUXILIARY MODE display, which indicates the control source (LOCAL, REMOTE, or SERIAL), AUTO or MANUAL mode, and the speed reference source. An example is shown below (IDC = 4-20 mA signal):

PRESS & HOLD

ENTER

### AUXILIARY MODE DISPLAY

